



City of Jonesboro  
**Invitation to Bid - Not an Order**

P.O. Box 1845  
 515 West Washington Ave.

Purchasing Office

Bid No. 2006:62

Jonesboro, Arkansas 72403

Date September 21, 2006

Sealed bids, subject to the conditions on the reverse hereof, and as may be attached hereto, will be received at this office until **2:00pm Wed, Oct 11, 2006** and then publicly opened, for furnishing the supplies, materials and/or services as described below and tabulated for presentation to the City Council on n/a.

F.O.B. See below

By: **Steve A. Kent**  
 Purchasing Agent  
 (870)932-0740

Maximum Delivery or completion time after issuance of Purchase Order or work ordered by the City see below days.

Item #	Description	Quantity	Unit	Unit Price	Amount
	<p><b>Special project</b> - Specifications for installing Sidewalk, Driveway and Drainage Boxes in an area of Jonesboro as listed in this bid. Bidder may click on <a href="http://www.jonesboro.org">www.jonesboro.org</a> for addendums or additional information under Purchasing no later than one week before opening. There are 5 (five) pages (front and back) to this bid. All pages must be returned as a complete bid.</p> <p>Bid <u>must</u> be signed or bid will be rejected.                      Bid number (2006:62) <u>must</u> be annotated on bidder's envelope.                      All prices shall be stated in the provided blank in specifications.                      Bidder shall submit a copy of their Arkansas State Contractor's License to qualify for award of this bid. License required. Bid will be rejected if not received with this bid.                      Quantities provided are estimates only and payments will be made on field measurements.                      After proper curing, successful bidder shall remove forms and shall backfill to finished grades and shall clean all disturbed areas.                      The Contractor shall furnish concrete, fill sand, backfill soil, expansion, key-ways, and any other materials required for proper installation. Contractor shall perform cleanup of all debris after completion of sections.                      The contractor shall perform hot and cold weather concreting in accordance with ACI specifications 306.1-90, 306R-88, and 305R-99.                      The Contractor shall be responsible for all utility locates before each job. Contractor shall also be responsible for any damage done to City and/or private property during project.                      The Contractor will be responsible for any and all traffic control in work areas.                      Successful bidder shall comply with City of Jonesboro standard specifications for construction which can be obtained from the City at Bidder's expense. All work shall comply with American Disabilities Act Guidelines (no exceptions).                      The City of Jonesboro reserves the right to accept or reject any or all or any part of any bid received.                      Contractor shall provide fax number so work order can be provided by the City. All jobs shall be completed within 30 calendar days from Notice to Proceed. Failure to do so shall result in a \$100.00 per day penalty until job is complete.                      Fax number: <u>870-932-6736</u>                      A bid bond and a performance bond will be required on this job. See page 2 (reverse side) section 9.                      Payments on jobs shall be made using the City of Jonesboro's bill paying schedule. Successful vender will submit all completed paperwork to the City using this schedule for payment(s).</p>				
Cash Discounts _____ % _____ Days					

**CITY OF JONESBORO, ARKANSAS**

**CONDITIONS OF BIDDING**

COMPLIANCE WITH THE FOLLOWING CONDITIONS IS NECESSARY FOR CONSIDERATION OF THIS BID:

1. **SIGNATURE** - This bid must be signed with the firm name and by an authorized officer, employee, or agent.
2. **SALES OR USE TAX** - is not to be shown in the bid price (unless otherwise stated) but is to be added by the vendor to the invoice billing to the City. The City is not exempt from Arkansas State Sales & Use Tax. Although Use Tax is not included in this bid, vendors are to register and pay tax direct to the Arkansas State Revenue Department.
3. **FREIGHT & OTHER DELIVERY CHARGES** - to designated City facility in Jonesboro must be included in bid. Charges may not be added after the bid is opened.
4. **DISCOUNTS** - Show rate, total amount, and latest day any discounts will be allowed after receipt of article and invoice, otherwise City will deduct allowed discount when payment is made.
5. **FIRM PRICE** - All prices quoted will remain firm for at least 30 days from date of bid, unless otherwise specified by the City or bidder.
6. **IDENTICAL BIDS** - In the event of two or more identical low bids, the contract may be awarded arbitrarily or for any reason to any of such bidders or split in any proportion between the said two or more bidders at the discretion of City.
7. **LIQUIDATED DAMAGES** - Liquidated damages shall be assessed beginning on the first day following the maximum delivery or completion time entered on this bid form and/or provided for by the plans and specifications.
8. **AMBIGUITY IN BID** - Any ambiguity in any bid as the result of omission, error, lack of clarity or non-compliance by the bidder with specifications, instructions, and all conditions of bidding shall be construed in the light most favorable to the City.
9. **CONSTRUCTION** -
  - A. When noted, the Contractor is to supply the City with evidence of having and maintaining proper and complete insurance, specifically Workman's Compensation Insurance in accordance with the laws of the State of Arkansas, Public Liability and Property Damage. All premiums and cost shall be paid by the Contractor. In no way will the City be responsible in case of accident.
  - B. When noted, a Certified check or bid bond in the amount of 5% of total bid shall accompany bid.
  - C. A performance Bond equaling the total amount of any bid exceeding \$3,000.00 must be provided for any contract for the repair, alteration or erection of any public building, public structure or public improvement (pursuant to Ark. Stat. SS51-632.SS51-565 as amended.)
10. The City reserves the right to reject any and all bids, to accept in whole or in part, to waive any informalities in bids received, to accept bids on materials or equipment with variations from specifications in those cases where efficiency of operation will not be impaired, and unless otherwise specified by the bidder, to accept any item in the bid. If unit prices and extensions thereof do not coincide, the City may accept the bid for the lesser amount whether reflected by the extension or by the correct multiple of the unit price.
11. **Minority Business Policy** - It is the policy of the City of Jonesboro that minority business enterprises shall have the maximum opportunity to participate in the city purchasing process. Therefore, the City of Jonesboro encourages all minority businesses to compete for, win and receive contracts for goods, services, and construction. The city also encourages all companies to subcontract portions of any city contract to minority business enterprises.

---

**INSTRUCTIONS TO BIDDERS**

(PLEASE READ CAREFULLY)

1. Submit bid on bid form on reverse side of this sheet. NO Facsimiles will be accepted.
2. Address all bids to: Purchasing Agent, P.O. Box 1845, Jonesboro, Arkansas 72403-1845 and make certain to indicate identifying bid number on the outside of bidder's envelope.
3. DO NOT include Federal Excise Tax in bid. City will furnish exemption certificate.
4. State Manufacturer, Brand Name, Model, etc for each item bid on.
5. Samples of items, when required, must be furnished free, and, if not called for within 30 days from date of bid opening, will be disposed of by City
6. Bids received after stated time will not be considered.
7. Be sure and read all conditions and verify amounts before submitting bids. No changes or additions will be allowed after submission.
8. Guarantees and warranties should be attached as a part of the bid as they may be a consideration in awarding a contract.
9. Delivery or contract completion time is to be shown, as this date may, where time is of the essence, determine the contract award.
10. Additional information may be obtained from the Purchasing Office.

**THE CITY RESERVES THE RIGHT TO ACCEPT PART OR ALL OF ANY SPECIFIC BID OR BIDS AND TO ACCEPT ANY BID WITH OR WITHOUT TRADE-IN. THE CITY FURTHER RESERVES THE RIGHT TO REJECT ALL BIDS, OR PART OR ALL OF ANY SPECIFIC BID OR BIDS.**

Click on Purchasing at [www.jonesboro.org](http://www.jonesboro.org) for any additional information.

Successful bidder shall furnish all labor, equipment, and materials to place and finish sections of work as listed below. All specifications on page one shall apply. The following amounts are estimates from the job site. All prices shall be figured using these estimates to sum up a total bid price. The City recognizes that quantities will fluctuate and final measurements will be made upon completion and inspection of each section of work.

ITEM	QUANTITY	UNIT PRICE	TOTAL
6' x 5' Grate Inlet	1	each \$ <u>4560.<sup>00</sup></u>	\$ <u>4560.<sup>00</sup></u>
4.5' x 4.5' Grate Inlet	2	each \$ <u>3900.<sup>00</sup></u>	\$ <u>7800.<sup>00</sup></u>
Sidewalk	600 sq. ft.	sq. ft. \$ <u>450</u>	\$ <u>2700.<sup>00</sup></u>
Driveway	400 sq. ft.	sq. ft. \$ <u>450</u>	\$ <u>1800.<sup>00</sup></u>
TOTAL BASE BID			\$ <u>16,860.<sup>00</sup></u>

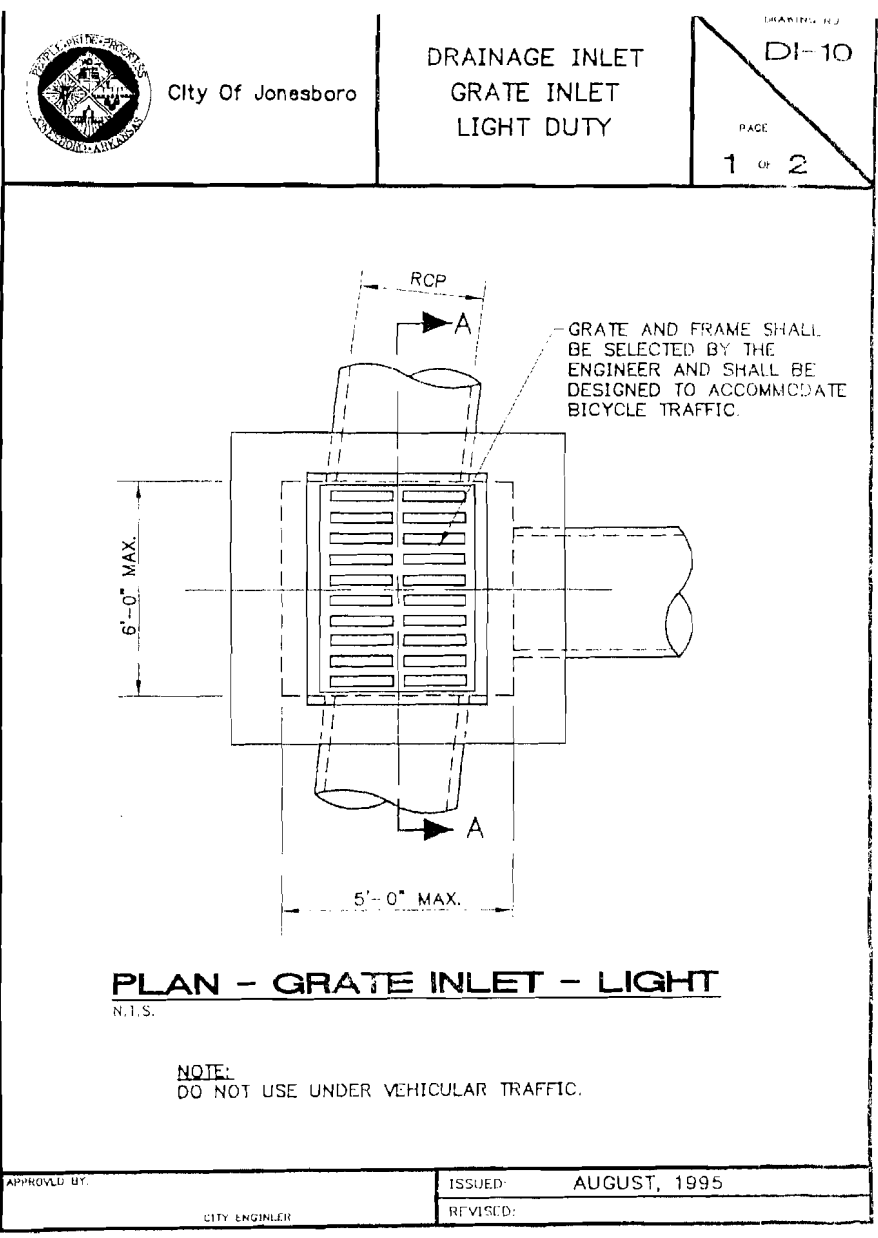

City Of Jonesboro



City of Jonesboro

DRAINAGE INLET  
GRATE INLET  
LIGHT DUTY

DRAWING NO.

DI-10

PAGE

2 of 2

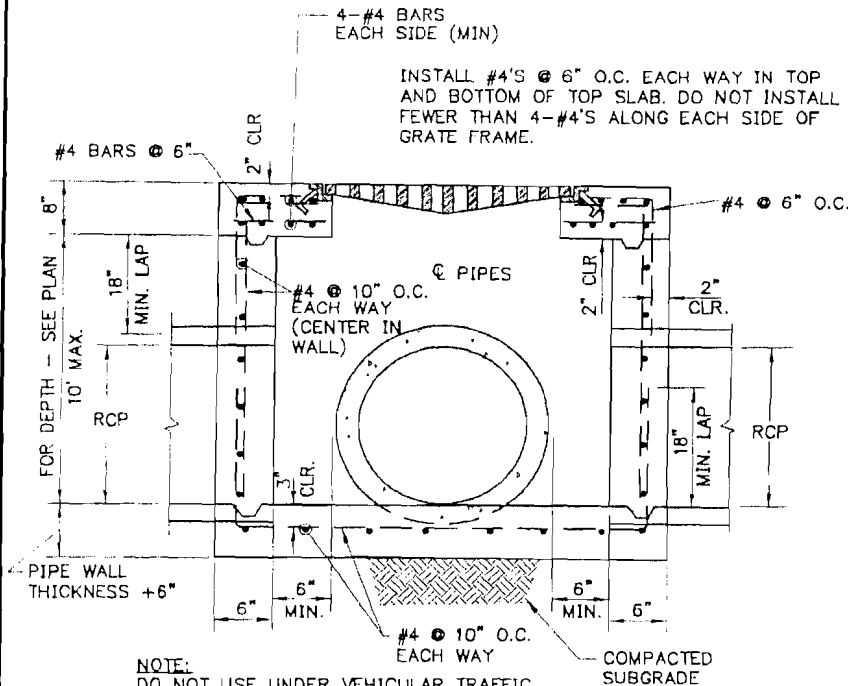

**SECTION "A-A" - GRATE INLET - LIGHT**

N.T.S.

**NOTES:**

1. AS APPROVED BY THE ENGINEER, WALLS MAY BE 8" BLOCK WITH 1/2" MORTAR. FILL CELLS WITH CONCRETE AND WITH #4'S @ 16" O.C.. BLOCK WALLS SHALL NOT BE USED UNDER VEHICULAR LOADING. MINIMUM DISTANCE FROM WALL TO PIPE SHALL BE 8" IF BLOCK WALLS ARE USED.
2. GRATE INLETS MORE THAN 3 FEET DEEP SHALL HAVE STANDARD MANHOLE STEPS PLACED @ 15" O.C.
3. SEE REINFORCING DETAIL FOR OPENING IN WALL OR SLAB.

APPROVED BY

CITY ENGINEER

ISSUED:

AUGUST, 1995

REVISED:

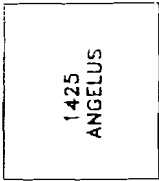
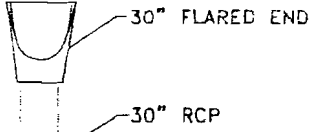

ANGELUS ST.

PARK AVE.

