



City Of Jonesboro

**CURB & GUTTER
COMBINATION TYPE
TYPE "A-18"**

DRAWING NO.

CG-4

PAGE
1 OF 2

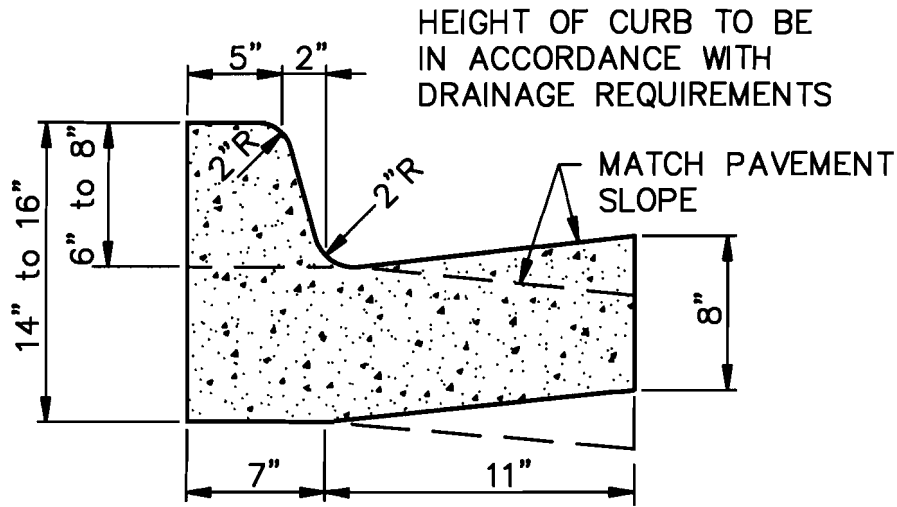

TYPE "A-18" (BARRIER) ARTERIAL STREETS

6" TYPICAL UNLESS
OTHERWISE NOTED.

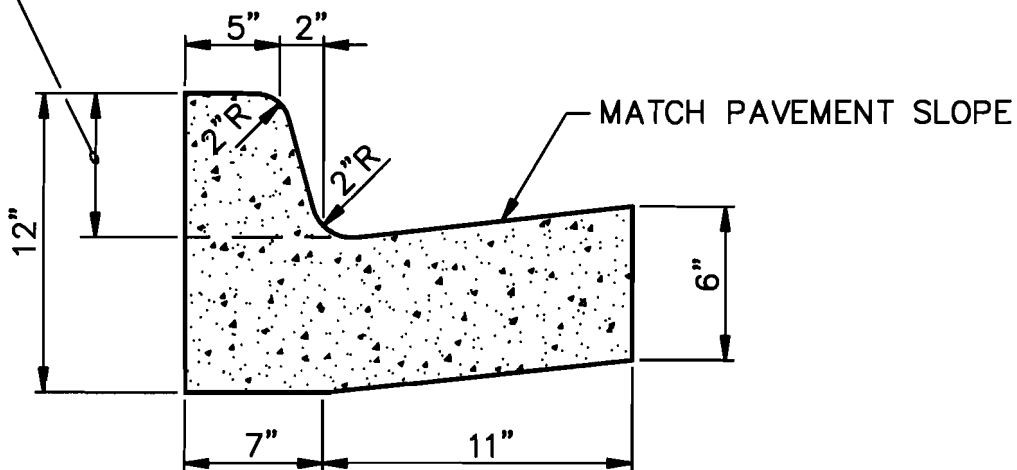

TYPE "A-18" (BARRIER) RESIDENTIAL & COLLECTOR STREETS

COMBINATION CURB AND GUTTER

N.T.S.

NOTE: CONTRACTION AND EXPANSION JOINTS SHALL BE
CONSTRUCTED IN ACCORDANCE WITH THE PLANS
AND SPECIFICATIONS.

APPROVED BY:

CITY ENGINEER

ISSUED:

OCTOBER 2007

REVISED:



City Of Jonesboro

CURB & GUTTER
COMBINATION TYPE
TYPE "A-18"

DRAWING NO.

CG-4

PAGE
2 OF 2

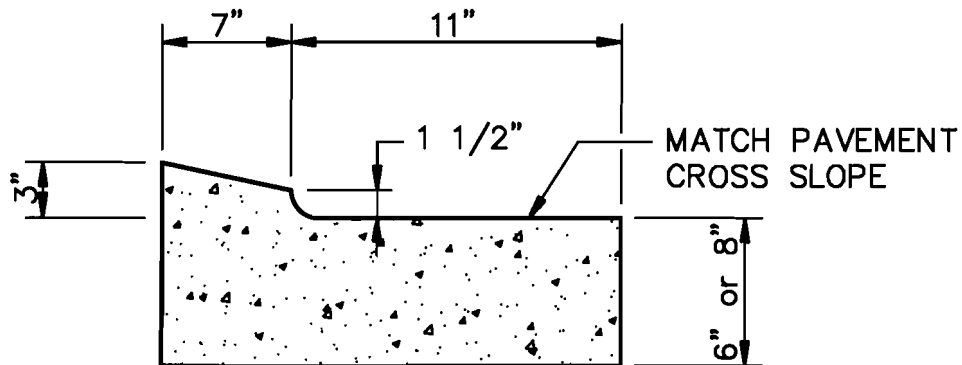

TYPE "A-18" - DEPRESSED

NOTE:
INSTALL DEPRESSED CURB & GUTTER AT
DRIVEWAYS AS SPECIFIED IN THE PLANS,
OR AS DIRECTED BY THE ENGINEER.

COMBINATION CURB AND GUTTER

N.T.S.

APPROVED BY:

CITY ENGINEER

ISSUED:

OCTOBER 2007

REVISED: