

# GUYED TOWERS

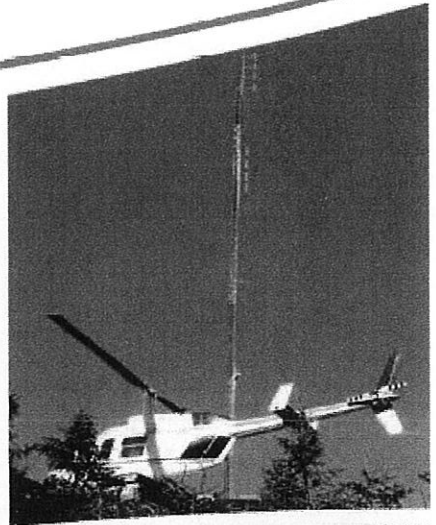

STANDARD 25G GUYED TOWER

**ROHN 25G**  
The first. The original.

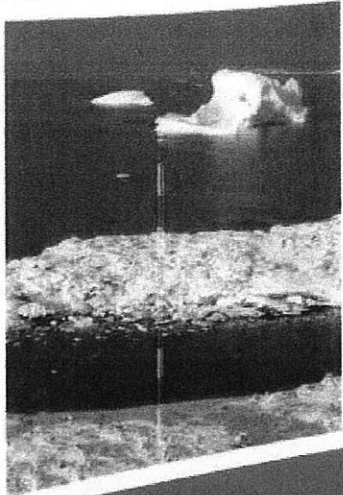
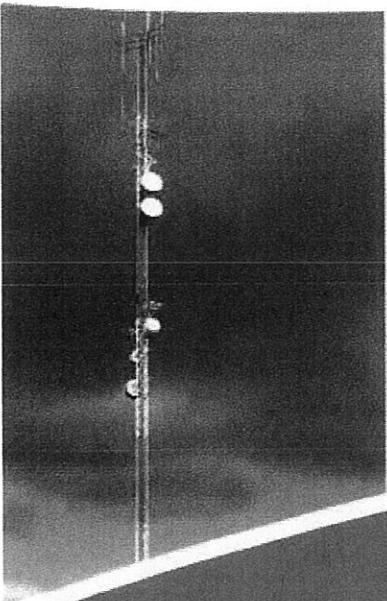

**25G**



**GENERAL USE**

The 25G is available in the standard 10' section length and a 7' length which is UPS shippable. The 25G uses double bolted joints, proven to be the best method of joining tower sections for sturdiness and dependability. As a guyed structure, the 25G standard designs rise to a height of 190'.

**FEATURES**

- Completely hot-dip galvanized after fabrication
- Built on an 11 1/4" equilateral triangle design
- High strength tubular legs joined by Zig-Zag® cross members
- Each 7' or 10' section contains all required nuts and bolts shipped with section
- Continuous solid round steel bracing

**CAUTION**

Mixing copies of ROHN towers with ROHN towers is dangerous and voids all engineering and warranty data supplied by ROHN. Materials used by others are not the same quality and have not been tested or engineered by ROHN. Mixing ROHN tower sections with non-ROHN products may cause tower failure or injury.

*Per Rev G requirements, any structure greater than 10' requires a climber safety device. Please see page 40 for ordering information.*



## STANDARD 25G GUYED TOWER SECTIONS

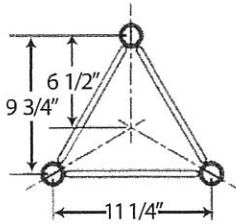

QUICK REFERENCE	
PARTS & ACCESSORIES	PAGES 37-40
GROUNDING INFORMATION	PAGES 41-43
FOUNDATION INFORMATION	PAGE 44

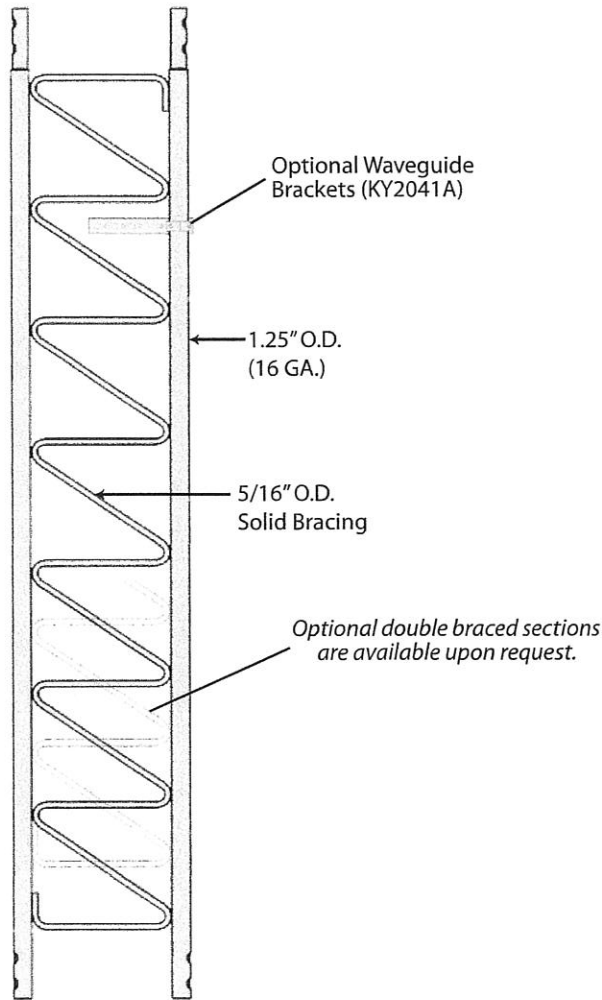

**STANDARD SECTION  
25G - 10' Section**

**OPTIONAL 7' SECTION  
25G7 - 7' Section**

The 7' Section is UPS shippable.

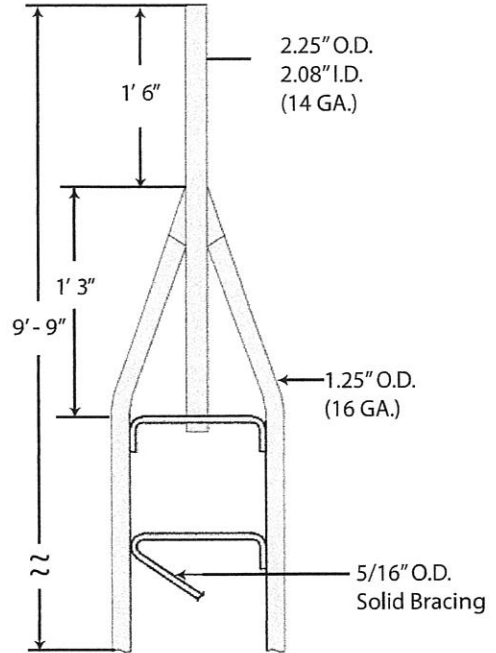

**STANDARD TOP SECTION  
25AG2**

Additional 25G top sections are shown on page 37.

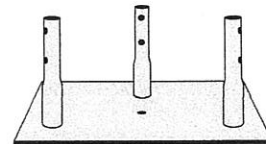

**CONCRETE BASE PLATE  
BPC25G\***

FOR USE WITH 3/4X12PP PIER PIN EMBEDDED IN CONCRETE.

Additional base sections are available, please see page 38.

\* Towers mounted on these bases must be bracketed or guyed at all times. Temporary steel guying may also be necessary during installation and dismantling.



**STANDARD DESIGN - 25G**  
90MPH REV. G [3-SECOND GUST]  
70MPH REV. F [FASTEST MILE]

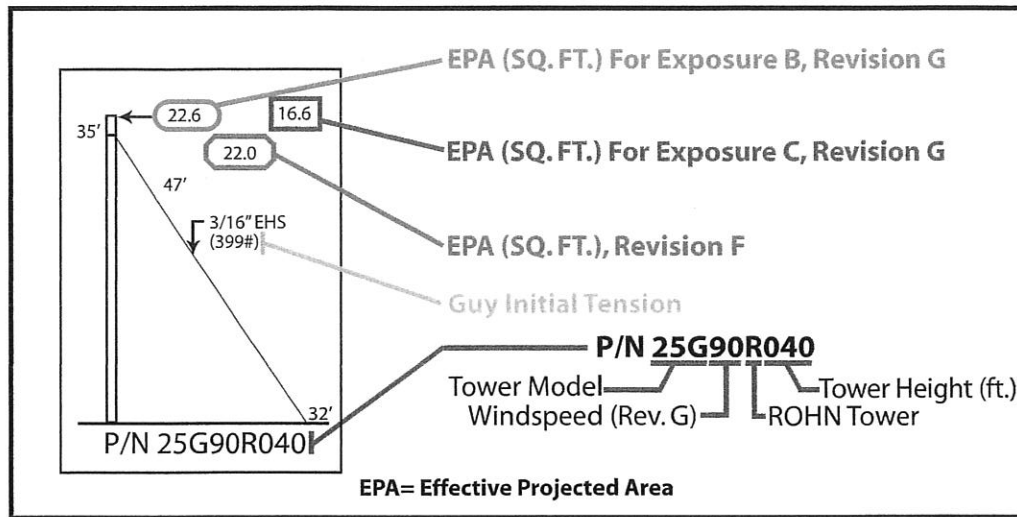

Tower and foundation installations should be performed by qualified and experienced personnel using assembly drawings provided with each tower. This document is to serve as a guide for sizing and purchasing the 25G tower.

**DESIGN NOTES:**

1. Tower designs are in accordance with ANSI/TIA-222-F and ANSI/TIA-222-G, Class I Structures, Topographic Category 1.
2. Design assumes towers are installed on level ground. Lower EPA values will apply for roof mounted towers or for sites located on unusual terrain.
3. Designs assume two 1/2" diameter lines on each tower face.
4. Anchor radius is from tower base to intersection of anchor rod with ground.
5. Guy chord lengths shown are based on level ground. Initial tensions for guys are shown in ( ) in pounds at 60° Fahrenheit.
6. Antenna and mounts are assumed symmetrically placed at the tower top.

**PARTS LIST NOTES:**

1. Items listed are required for complete guyed towers.
2. Base and anchor foundation refer to standard foundation designations.
3. Guys provided with each standard tower are based on level ground conditions with an additional 6% length.
4. Rev G anchor grounding (AGK1GGX) and base grounding (BGK3GGX) are included with the tower material.
5. Installation information and a safety package (P/N: ACWS) are included with each tower.
6. Parts lists are subject to change based on availability or revised design criteria.

**FOR FOUNDATION INFORMATION, PLEASE SEE PAGES 41-43.**  
**FOR GENERAL INSTALLATION INFORMATION, PLEASE SEE PAGES 144-149.**



## STANDARD DESIGN - 25G

### 90MPH REV. G, 70MPH REV. F

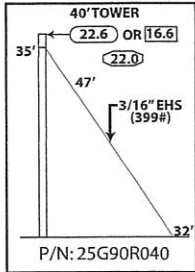

TOWER PARTS INCLUDED	25G	25AG2	BPC25G	GA25GD	FDNS	
					BASE	ANCHOR
	3	1	1	1	CB1G	AB2
GUYS & CONNECTIONS INCLUDED	3/16EHS	BG2142	5/16THH	1/2TBE&J	TBSAFETY	
	175'	6	6	3	3	
ANCHORS & GROUNDING INCLUDED	GAC3455TOP	AGK1GGX	BGK3GGX	CPC.5/.75	3/4x12PP	
	3	1	3	3	1	

**40' ROHN 25G**  
All parts shown in table are included when ordering  
Part No: 25G90R040

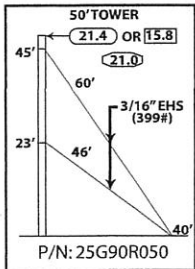

TOWER PARTS INCLUDED	25G	25AG2	BPC25G	GA25GD	FDNS	
					BASE	ANCHOR
	4	1	1	2	CB1G	AB2
GUYS & CONNECTIONS INCLUDED	3/16EHS	BG2142	5/16THH	1/2TBE&J	TBSAFETY	
	350'	12	12	6	3	
ANCHORS & GROUNDING INCLUDED	GAC3455TOP	AGK1GGX	BGK3GGX	CPC.5/.75	3/4x12PP	
	3	1	3	3	1	

**50' ROHN 25G**  
All parts shown in table are included when ordering  
Part No: 25G90R050

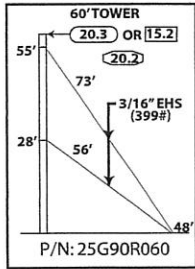

TOWER PARTS INCLUDED	25G	25AG2	BPC25G	GA25GD	FDNS	
					BASE	ANCHOR
	5	1	1	2	CB1G	AB2
GUYS & CONNECTIONS INCLUDED	3/16EHS	BG2142	5/16THH	1/2TBE&J	TBSAFETY	
	425'	12	12	6	3	
ANCHORS & GROUNDING INCLUDED	GAC3455TOP	AGK1GGX	BGK3GGX	CPC.5/.75	3/4x12PP	
	3	1	3	3	1	

**60' ROHN 25G**  
All parts shown in table are included when ordering  
Part No: 25G90R060

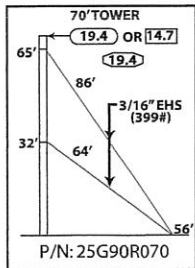

TOWER PARTS INCLUDED	25G	25AG2	BPC25G	GA25GD	FDNS	
					BASE	ANCHOR
	6	1	1	2	CB1G	AB2
GUYS & CONNECTIONS INCLUDED	3/16EHS	BG2142	5/16THH	1/2TBE&J	TBSAFETY	
	500'	12	12	6	3	
ANCHORS & GROUNDING INCLUDED	GAC3455TOP	AGK1GGX	BGK3GGX	CPC.5/.75	3/4x12PP	
	3	1	3	3	1	

**70' ROHN 25G**  
All parts shown in table are included when ordering  
Part No: 25G90R070

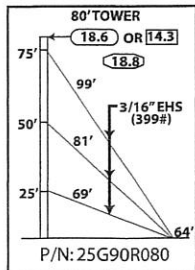

TOWER PARTS INCLUDED	25G	25AG2	BPC25G	GA25GD	FDNS	
					BASE	ANCHOR
	7	1	1	3	CB1G	AB2
GUYS & CONNECTIONS INCLUDED	3/16EHS	BG2142	5/16THH	1/2TBE&J	TBSAFETY	
	800'	18	18	9	3	
ANCHORS & GROUNDING INCLUDED	GAC3455TOP	AGK1GGX	BGK3GGX	CPC.5/.75	3/4x12PP	
	3	1	3	3	1	

**80' ROHN 25G**  
All parts shown in table are included when ordering  
Part No: 25G90R080

