



City of Jonesboro

Municipal Center
300 S. Church Street
Jonesboro, AR 72401

Meeting Agenda Finance & Administration Council Committee

Tuesday, February 11, 2025

4:00 PM

Municipal Center, 300 S. Church

1. CALL TO ORDER

2. ROLL CALL (ELECTRONIC ATTENDANCE) CONFIRMED BY CITY CLERK APRIL LEGGETT

3. APPROVAL OF MINUTES

[MIN-25:009](#) Minutes for the Finance Committee meeting on Tuesday, January 28, 2025.

Attachments: [Minutes](#)

4. NEW BUSINESS

RESOLUTIONS TO BE INTRODUCED

[RES-25:011](#) A RESOLUTION TO WAIVE COMPETITIVE BIDDING AND AUTHORIZE PURCHASE OF RAB ALED5T52/PCT-LED POST TOP LIGHT-OR EQUIVALENT LIGHT FIXTURES AND RAB PR4-11-15D2-OR EQUIVALENT LIGHT POLES.

Sponsors: Grants, Engineering and Finance

Attachments: [Lighting Specs - Tec Electric.pdf](#)
[Quote 1355173-00 \(002\).pdf](#)

5. PENDING ITEMS

6. OTHER BUSINESS

7. PUBLIC COMMENTS

8. ADJOURNMENT



City of Jonesboro

300 S. Church Street
Jonesboro, AR 72401

Text File

File Number: MIN-25:009

Agenda Date:

Version: 1

Status: To Be Introduced

In Control: Finance & Administration Council Committee

File Type: Minutes

Minutes for the Finance Committee meeting on Tuesday, January 28,2025.



City of Jonesboro

Municipal Center
300 S. Church Street
Jonesboro, AR 72401

Meeting Minutes Finance & Administration Council Committee

Tuesday, January 28, 2025

4:00 PM

Municipal Center, 300 S. Church

1. CALL TO ORDER

2. ROLL CALL (ELECTRONIC ATTENDANCE) CONFIRMED BY CITY CLERK APRIL LEGGETT

Present 5 - Joe Hafner; Ann Williams; John Street; Brian Emison and Anthony Coleman

Absent 2 - Charles Coleman and David McClain

3. ELECTION OF A CHAIR

A motion was made by Councilmember John Street, seconded by Councilmember Brian Emison, that Councilmember Joe Hafner be nominated as Chair of the Finance Committee. All voted aye.

4. APPROVAL OF MINUTES

[MIN-24:115](#)

MINUTES FOR THE SPECIAL CALLED FINANCE & ADMINISTRATION COUNCIL COMMITTEE MEETING (WORKING SESSION) ON MONDAY, DECEMBER 30, 2024

Attachments: [Minutes](#)

A motion was made by John Street, seconded by Brian Emison, that this matter be Passed . The motion PASSED with the following vote.

Aye: 4 - Ann Williams; John Street; Brian Emison and Anthony Coleman

Absent: 2 - Charles Coleman and David McClain

[MIN-24:116](#)

MINUTES FOR THE FINANCE & ADMINISTRATION COUNCIL COMMITTEE MEETING ON TUESDAY, DECEMBER 31, 2024

Attachments: [Finance Minutes 1231024.pdf](#)

A motion was made by John Street, seconded by Brian Emison, that this matter be Passed . The motion PASSED with the following vote.

Aye: 4 - Ann Williams; John Street; Brian Emison and Anthony Coleman

Absent: 2 - Charles Coleman and David McClain

5. NEW BUSINESS

RESOLUTIONS TO BE INTRODUCED

[RES-25:003](#)

A RESOLUTION AUTHORIZING THE CITY OF JONESBORO, ARKANSAS, TO ENTER INTO AGREEMENT WITH THE BUREAU OF JUSTICE ASSISTANCE TO ACCEPT GRANT FUNDS

Sponsors: Grants, Police Department and Finance

Councilmember Ann Williams said, what is this as far as... I wasn't real sure about what this meant. As far as the ramifications of it. Police Department Chief Rick Elliott approached the podium and said, the BJA (Bureau of Justice Assistance) Grant is a grant that we've had well over the past 10 years. It comes out every year. We've applied every year and have been successful in getting this grant every year. And for us and the city, it just helps offset some of the normal budgetary items. Instead of coming out of the city budget and buying these items, we get it funded through the federal grant money. So, it's a pretty simple grant that we have applied for every year and again have been successful at least the last 10 plus years. Save the taxpayers of Jonesboro substantial amount of money during this time. But it's a no match grant. It's just a simple application grant that's out there. To be honest there's... most agencies in the state, they don't have a Grants Department, they missed this opportunity. So, by having the Grants Department in place it's... Generally, grants involving law enforcement, they're more of an application style grant instead of having to write a long narrative as compared to some of these other grants. They're, I would say, easier to write just kind of fill in the blanks. They ask for certain information. But again, we've been successful in this grant for 10 plus years. Earlier dollar amounts were less than this. Over the past several years that amount, we've actually seen an increase in these dollars. So, we're fortunate this year, it's \$39,180. So again, you can see the amount of equipment we're able to purchase instead of coming out of the budget, so it's a huge savings for all involved. Councilmember Ann Williams said, that's great, that's great. I just didn't know the specifics of it but that's great. Chief Rick Elliot said, yeah, it's been out there a long time. And like I said, we as a city, we're just fortunate enough that we've, year after year, been able to get awarded this grant. Chairman Joe Hafner said, thanks Chief. Chief Rick Elliot said, yes sir.

A motion was made by John Street, seconded by Brian Emison, that this matter be Recommended to Council . The motion PASSED with the following vote.

Aye: 4 - Ann Williams;John Street;Brian Emison and Anthony Coleman

Absent: 2 - Charles Coleman and David McClain

[RES-25:004](#)

RESOLUTION AUTHORIZING CITY OF JONESBORO, ARKANSAS GRANTS AND COMMUNITY DEVELOPMENT DEPARTMENT TO APPLY FOR THE FY2025 SOCIAL DETERMINANTS OF HEALTH GRANT FROM THE BLUE AND YOU FOUNDATION

Sponsors: Grants and Parks & Recreation

A motion was made by John Street, seconded by Brian Emison, that this matter be Recommended to Council . The motion PASSED with the following vote.

Aye: 4 - Ann Williams;John Street;Brian Emison and Anthony Coleman

Absent: 2 - Charles Coleman and David McClain

[RES-25:008](#)

A RESOLUTION AUTHORIZING THE CITY OF JONESBORO TO ENTER INTO A

TWO-YEAR LEASE CONTRACT FOR THE PURCHASE OF THREE SANITATION AUTOMATED TRUCKS, ONE FRONT LOAD SANITATION TRUCK AND ONE REAR LOAD SANITATION TRUCK

Sponsors: Sanitation and Finance

Attachments: [final Proposal 5 sanitation updated 1-15-2025.pdf](#)

Chairman Joe Hafner said, I just had one question or comment for clarification. I don't know if Steve or Brain want to come up front. On the schedule that was presented, it shows the truck, 2025 Mac ASL 3 units, price \$426,049.77 term 25 months, payment \$8,797. Our payment will be \$8,797 times three, right? Because that's the payment. Finance Department Director Steve Purtee approached the podium and said, that is correct. That would be times three. Chairman Joe Hafner said, and I can tell you the pricing is right in line with what we're seeing, or what I've seen through our company that I'm involved in so. Actually, the 2025 rear loader looks a little bit lower than what we just paid for one. So, I'll talk to Jamie McCoy about that. Director Steve Purtee said, you want to buy ours? Chairman Joe Hafner said no. They're definitely... these trucks are very expensive.

Councilmember Ann Williams said, I'm real impressed by the... what is it the knuckle boom truck that picks up limbs that comes through that we've... one of our recent purchases a couple of years ago, right? And I'm really impressed with how that works. And I know it was expensive but it's a good thing to have.

Councilmember Dr. Anthony Coleman said, yes sir, thank you. Just a question on terms. When you say lease, and I just need understanding, maybe you or Brain can help me. But when they say lease and then we're responsible for maintenance and insurance and all of that... I understand the insurance but the maintenance part of it. So, when I think leasing a vehicle, I thought they were responsible. Is this a loan or a lease? I mean the terms is what's getting me. Director Steve Purtee said, it is technically a capital lease. We own the asset until the conclusion of the lease. At that time there is a determination made as to whether the vehicle will be retained by us or will be turned back to the supplier, in this case, at the conclusion of the lease. So, it affords us the opportunity to kind of have the best of both worlds to determine the condition of the equipment for that two-year period and then make that final call as to whether it should retain in our fleet or go back to the supplier and then we start over again.

Councilmember Dr. Anthony Coleman said, let me ask you this too. So, was this brought before the Finance Committee first already? This proposal or was this just brought during the budget? Chairman Joe Hafner said, it's part of budget.

Councilmember Dr. Anthony Coleman said, I know it's part of the budget, but I'm asking did we discuss it before the budget? This. No? Director Steve Purtee said, we make the determination as to what will be the plans for the upcoming year. We did that last fall as we were developing the budget, and then at that point it was determined that these particular leases are expiring. Those units are reaching the end of their two year period. We make those determinations and then reset as to what our plans are for 2025. And that's what we're presenting today is from those budget plans, what was included in the budget. This is the contract relative to those lease programs.

Councilmember Dr. Anthony Coleman said, sure, sure. I just didn't see it so thank you.

Councilmember Brain Emison said, I'll just say the terms that we see from Arvest, when it comes to these lease agreements that we see out of them. The 4.89% that we see on that kind of stuff, I mean it's really aggressive they do a really good job

whenever it comes out to their government leasing and lending side of it. So, 4.89% for the run of that term, it's even better than what you can necessarily walk in the front door and be able to pull out, so. Chairman Joe Hafner said, what are you seeing, like 7.50% or so right now? Councilmember Brian Emison said, yeah. If you walked in, basically... even tax-free rates that you're getting out of that, you would see somewhere in the neighborhood of, at the low end it would be the high sixes. But you probably be playing around at the 7.50-8%. Just depending on what kind of collateral that you have being put up. And of course, what these are going through you don't necessarily know the value of your collateral that you're going to get at any given time. But I mean these are some very aggressive terms for that so. Chairman Joe Hafner said, it's good for Arvest bank right. Councilmember Brian Emison said, yeah. Chairman Joe Hafner said, and for Steve and his team for working on that.

A motion was made by John Street, seconded by Brian Emison, that this matter be Recommended to Council . The motion PASSED with the following vote.

Aye: 4 - Ann Williams;John Street;Brian Emison and Anthony Coleman

Absent: 2 - Charles Coleman and David McClain

[RES-25:009](#)

A RESOLUTION TO WAIVE COMPETITIVE BIDDING AND AUTHORIZE PURCHASE OF POLICE PACKAGE CHEVROLET TAHOES AND UPFITTING EQUIPMENT

Sponsors: Police Department and Finance

Attachments: [Tahoe Invoices.pdf](#)

Chairman Joe Hafner said, I'm going to read RES-25:009 as it was presented, but there's been a request for an amendment. So, I'll read it and then I'll let you know what the amendment is and y'all make a motion on whether or not to include it.

Councilmember John Street motioned, seconded by Councilmember Ann Williams, to amend by adding an average cost of to Section one, RES-25:009. All voted aye.

Councilmember Dr. Anthony Coleman said, if we didn't have any questions about the average of. Chairman Joe Hafner said, it just the amendment. Councilmember Dr. Anthony Coleman said, adding that and then now if we have questions. Chairman Joe Hafner said, yeah now were doing the questions on the actual resolution. I mean because one is for \$63,730.12, the other for \$66,230.12 that should be the average. Councilmember Dr. Anthony Coleman said, ok.

Councilmember Dr. Anthony Coleman said, I have a question. How long does it take to get these vehicles because? Police Department Chief Rick Elliott approached the podium and said, I'll give you a point of clarity on this also. These two vehicles particular are actually 2024's, so 2025's are not on the state bid the 2024's were on state bid and we're getting those at that price. So, they're sitting on the lot currently at Superior Ford. Once this goes to council next week, then paperwork will be sent to them, they've already... will have equipment... they're an upfitter. And hopefully in two or three weeks they'll be ready to be delivered. So, our fleet of vehicles that we have coming this weekend. This is one or three contracts that's going to be coming before you here in the near future. I have six more Explorers that are 2024's that are sitting on the lot at Superior and we just got done fitting price on those. So that would be the next resolution coming up at the next finance. And then for the 2025 Explorers, that we're having to order from the factory, there's a 60 to 90 day turnaround time from the manufacturing to deliver to the dealer. Then there's upfitting after that so that's pushing us out several months down the road. So, the short answer to your question is these

two vehicles come pretty quick, the next six vehicles that's sitting there now will come after two more meetings through approval. And then the others will follow later on. Does that? Councilmember Dr. Anthony Coleman said, yes, yes. It answers my question. Yes. Thank you. Chief Rick Elliott said, by working a deal out with Superior on these first two vehicles, I actually saved the city somewhere \$30,000 plus dollars because they are 2024 models. There was almost a \$5,000 increase from 24's to 25's. So Superior was nice enough to hang on to these from December until now. And so, we're just, again, we look at as cost savings. We're still benefiting from what we're getting from budget. During our budget cycle we were allotted 25 vehicles this year. So, I'm hoping to come in under the budgeted dollar amounts based on 2025 models. So, save money at the end of the day is the way it's working out.

A motion was made by John Street, seconded by Brian Emison, that this matter be Recommended to Council . The motion PASSED with the following vote.

Aye: 4 - Ann Williams;John Street;Brian Emison and Anthony Coleman

Absent: 2 - Charles Coleman and David McClain

6. PENDING ITEMS

Chairman Joe Hafner said, I just have a question or comment. I assume the Revenue Bond stuff is still being worked on and hopefully we'll see that pretty soon. And I had asked for additional budget detail on the Capital items. I didn't know the status of supplying us with that additional detail.

Chief Administrative Officer Brain Richardson approached the podium and said, similar to how the city, last year, started giving some updates on Capital Improvement Projects through the Public Services Committee. I think we're going to transition that more towards just the full City Council. Maybe once every other month. So, we might put something on next week's agenda. Just kind of give you a rundown of where the current Capital Improvement Projects sit. Some of them that are completed that are still on that list, so we're planning on putting that as presentation on the next council meeting. Chairman Joe Hafner said, thank you.

7. OTHER BUSINESS

8. PUBLIC COMMENTS

9. ADJOURNMENT

A motion was made by Brian Emison, seconded by John Street, that this meeting be Adjourned. The motion PASSED with the following vote.

Aye: 4 - Ann Williams;John Street;Brian Emison and Anthony Coleman

Absent: 2 - Charles Coleman and David McClain



City of Jonesboro

300 S. Church Street
Jonesboro, AR 72401

Text File

File Number: RES-25:011

Agenda Date:

Version: 1

Status: To Be Introduced

In Control: Finance & Administration Council Committee

File Type: Resolution

A RESOLUTION TO WAIVE COMPETITIVE BIDDING AND AUTHORIZE PURCHASE OF RAB ALED5T52/PCT-LED POST TOP LIGHT-OR EQUIVALENT LIGHT FIXTURES AND RAB PR4-11-15D2-OR EQUIVALENT LIGHT POLES.

WHEREAS, the City of Jonesboro Mayor's office has determined the previously mentioned above light fixtures and light poles to be the city standard for all pedestrian-friendly and pedestrian-priority streets; and

WHEREAS, a local distributor can stock these fixtures as part of their normal inventory, and can maintain an adequate supply of replacement parts as needed.

NOW, THEREFORE BE IT RESOLVED BY THE CITY COUNCIL OF THE CITY OF JONESBORO, ARKANSAS THAT:

SECTION 1: The specified light fixtures and light poles are available from TEC ELECTRIC of Jonesboro, AR for a unit price of \$512.82 per a RAB ALED5T52/PCT-led post top light-or equivalent light fixtures and a unit price of \$493.59 per a RAB PR4-11-15D2-or equivalent light poles in addition to local sales tax.

SECTION 2: Due to the need to be able to access this lighting and replacement parts quickly for the preservation of public safety in the community, the City Council in accordance with the terms of A.C.A. Section 14-58-303 hereby waive the requirement of competitive bidding and direct the purchasing agent to purchase the above-described light fixtures and light poles for the prices set forth above.

General Definition of Work To Be Performed by Contractor:

The contractor shall install all service points according to the plans and City, Water and Light standards. All augured bases shall be installed flat / level per manufacturer recommendations. The contractor shall install poles to bases per manufacturer's recommendations and torque bolts and nuts per manufacturer's recommendations. The contractor shall mount lights in a secure manner and perform all electrical connections with correct wire nuts and tape. The contractor shall install underground electrical conduit per plans and the National Electric Code. The contractor shall install all electrical conductors in accordance with the plans in a way that does not damage the conductors. The contractor shall backfill and seed or sod all trenches and disturbed ground.

Specifications of Fixtures and Poles (Fixtures and Poles to be supplied by the city):

1. Light Fixtures – Quantity (77)

RAB ALED5752/PCT – LED Post Top Light – Or Equivalent

- Wattage – 52W
- Color Temperature – 5,100K
- Voltage – 120-277V
- UL Listing – Wet Locations
- Life Hours – 100,000 Hours
- Lumens – 3,089
- Finish – Bronze
- Height – 22.5 in.
- Diameter – 16 in.
- Weight – 21.8 lbs.
- Warranty – 5-Year Limited

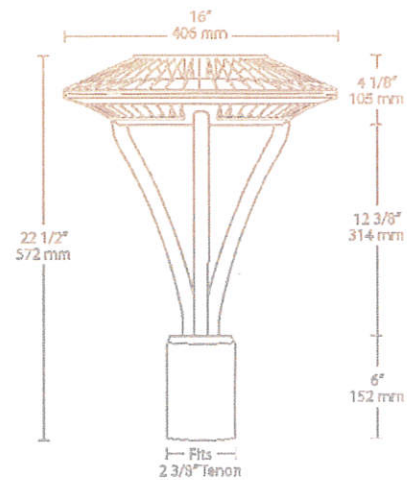

2. Light Poles - Quantity (77)

RAB PR4-11-15D2 – Or Equivalent

- Shaft Size – 4"
- Shaft PSI – 46,000 minimum yield
- Hand Hole – Reinforced with grounding lug and removable cover
- Color – Bronze Power Coating
- Height – 15'
- Gauge – 11
- Wall Thickness – 1/8
- Slotted Base Plates 36,000 p.s.i

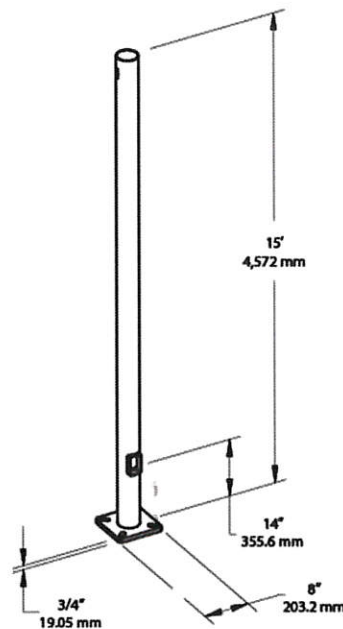

Specifications of Auger Bases (Bases to be supplied by the city):

TEC ELECTRIC

| | | | |
|---------------------|-----------------|----------------------------|----------------|
| Entered Date | Taken By | Customer # | Order # |
| 1/13/25 | LR | 12505 | 1355173-00 |
| PO # | | Requested Ship Date | Page # |
| 77 STREET LIGHTS | | 1/13/25 | 1 |

| | |
|--|--|
| Bill To | Ship To |
| CITY OF JONESBORO P.O. BOX 1845 JONESBORO, AR 72403-1845 | CITY OF JONESBORO P.O. BOX 1845 JONESBORO, AR 72403-1845 |

| |
|---|
| Correspondence To |
| Tec Electric 1900 S. Church St. Jonesboro, AR 72401 |

| | | | |
|---------------------|-------------|----------------|--------------|
| Instructions | | | |
| Ship Point | Via | Shipped | Terms |
| TEC Electric | Customer PU | | NET 25TH |

| |
|--------------|
| Notes |
| |

| Line | Product and Description | Room ID | Order Quantity | Shipped Quantity | Qty UM | Unit Price | Price UM | Amount(Net) |
|----------|---|-----------------------------|----------------|------------------|--------|------------|-----------------|------------------|
| 1 | ALED5T78 AREA LIGHT POST TOP 78W COOL LED TYPE V CLEAR | | 77.00 | 77.00 | EACH | 512.82 | EACH | 39,487.14 |
| 2 | PR4-11-15WT POLE | | 77.00 | 77.00 | EACH | 493.59 | EACH | 38,006.43 |
| 2 | Lines Total | Total Order Quantity | 154.00 | | | | Subtotal | 77,493.57 |
| | | | | | | | Taxes | 6,586.96 |
| | | | | | | | Total | 84,080.53 |