



# City of Jonesboro

Municipal Center  
300 S. Church Street  
Jonesboro, AR 72401

## Meeting Agenda Finance & Administration Council Committee

---

Tuesday, April 12, 2022

4:00 PM

Municipal Center, 300 S. Church

---

### 1. Call To Order

### 2. Roll Call by City Clerk April Leggett

### 3. Approval of minutes

[MIN-22:026](#) MINUTES FOR THE FINANCE & ADMINISTRATION MEETING ON MARCH 29, 2022

Attachments: [Finance Minutes 03292022](#)

### 4. New Business

#### *RESOLUTIONS TO BE INTRODUCED*

[RES-22:068](#) A RESOLUTION OF THE CITY OF JONESBORO, ARKANSAS TO ENTER INTO A CONTRACT WITH WAGNER GENERAL CONTRACTORS, INC. FOR THE RENOVATIONS TO THE JONESBORO RECREATIONAL CENTER

Sponsors: Engineering and Parks & Recreation

Attachments: [Certified Bid Tab 03.23.22](#)  
[Agreement Jonesboro Recreational Center](#)

[RES-22:069](#) A RESOLUTION AUTHORIZING THE CITY OF JONESBORO GRANTS AND COMMUNITY DEVELOPMENT DEPARTMENT TO APPLY FOR THE FY 2023 SELECTIVE TRAFFIC ENFORCEMENT PROGRAM (STEP) FROM THE ARKANSAS STATE POLICE

Sponsors: Grants and Police Department

[RES-22:070](#) A RESOLUTION OF THE CITY OF JONESBORO, ARKANSAS TO CONTRACT WITH JONESBORO MONUMENT COMPANY FOR SPONSORSHIP OF ONE ATHLETIC FIELD AT THE SOUTHSIDE SOFTBALL SPORTS COMPLEX

Sponsors: Parks & Recreation and Finance

Attachments: [Exhibit A - Jonesboro Monument Company Southside Complex 2022](#)

[RES-22:071](#) A RESOLUTION TO WAIVE COMPETITIVE BIDDING AND AUTHORIZE THE MAYOR TO ENTER INTO AN AGREEMENT WITH ACTIVE NETWORK, LLC FOR THE PURCHASE OF POINT OF SALE EQUIPMENT FOR THE PARKS DEPARTMENT

**Sponsors:** Parks & Recreation and Finance

**Attachments:** [ActiveNet POS Invoice](#)

**RES-22:072** A RESOLUTION OF THE CITY OF JONESBORO, ARKANSAS TO ENTER INTO A CHANGE ORDER WITH RAMSONS INC.FOR THE JONESBORO SHOOTING SPORTS COMPLEX PHASE 1C (2020:07)

**Sponsors:** Parks & Recreation, Police Department and Finance

**Attachments:** [Proposal Request](#)

**RES-22:073** A RESOLUTION TO THE CITY OF JONESBORO, ARKANSAS AUTHORIZING THE DONATION OF RIGHT-OF-WAY TO THE ARKANSAS STATE HIGHWAY AND TRANSPORTATION DEPARTMENT FOR ROAD MAINTENANCE PURPOSES

**Sponsors:** Engineering

**Attachments:** [ROW plans](#)  
[Agreement for Donation](#)

**5. Pending Items**

**6. Other Business**

**7. Public Comments**

**8. Adjournment**



## Legislation Details (With Text)

---

**File #:** MIN-22:026    **Version:** 1    **Name:** MINUTES FOR THE FINANCE & ADMINISTRATION MEETING ON MARCH 29, 2022

**Type:** Minutes    **Status:** To Be Introduced

**File created:** 3/29/2022    **In control:** Finance & Administration Council Committee

**On agenda:**    **Final action:**

**Title:** MINUTES FOR THE FINANCE & ADMINISTRATION MEETING ON MARCH 29, 2022

**Sponsors:**

**Indexes:**

**Code sections:**

**Attachments:** [Finance Minutes 03292022](#)

Date	Ver.	Action By	Action	Result
------	------	-----------	--------	--------

MINUTES FOR THE FINANCE & ADMINISTRATION MEETING ON MARCH 29, 2022



# City of Jonesboro

Municipal Center  
300 S. Church Street  
Jonesboro, AR 72401

## Meeting Minutes Finance & Administration Council Committee

---

Tuesday, March 29, 2022

4:00 PM

Municipal Center, 300 S. Church

---

### 1. Call To Order

### 2. Roll Call by City Clerk April Leggett

*Councilmember David McClain entered the meeting at 4:02 p.m. after roll call and after passage of the minutes, but before discussion of ORD-22:017.*

**Present** 6 - Charles Coleman; Ann Williams; John Street; David McClain; LJ Bryant and Joe Hafner

**Absent** 1 - Brian Emison

### 3. Approval of minutes

[MIN-22:018](#)

MINUTES FOR THE FINANCE COMMITTEE MEETING ON MARCH 8, 2022

**Attachments:** [FINANCE Minutes 03082022](#)

**A motion was made by Councilperson John Street, seconded by Councilperson Charles Coleman, that this matter be Passed . The motion PASSED with the following vote.**

**Aye:** 4 - Charles Coleman; Ann Williams; John Street and LJ Bryant

**Absent:** 2 - David McClain and Brian Emison

### 4. New Business

#### ORDINANCES TO BE INTRODUCED

[ORD-22:017](#)

AN ORDINANCE TO WAIVE COMPETITIVE BIDDING AND AUTHORIZE PURCHASE OF LICENSE PLATE RECOGNITION EQUIPMENT AND SOFTWARE FOR THE POLICE DEPARTMENT

**Attachments:** [Vigilant](#)

*Councilmember John Street said, Mr. Chairman, before the meeting, I was asked to make an amendment on the recurring fee and change that to \$48,500 and then the one-time fee would result in a change to \$9,380 and the recurring fees are all of those that are highlighted and the remainder of those fees are what make up the one-time fee. Councilmember John Street motioned, seconded by Councilmember LJ Bryant, to amend ORD-22:017 to reflect the changes in fees from the recurring fees of \$57,080 to*



\$48,500 and the one-time fee from \$8,580 to \$9,380. All voted aye.

Chairman Joe Hafner said, let the record reflect that Councilmember David McClain is now present.

Councilmember McClain asked, how many are we planning on? Does it say how many license plates? I see license plate recognition, other cameras, body worn cameras or they do all that, but we just need the license plate recognition? Police Chief Rick Elliott said, this is LPR technology, software to do analytics with and to run the systems we currently involved in. This particular brand is a Motorola product and it is used by our federal law enforcement partners and plus other major agencies around us and that has given us the capability to share information with them and they are also sharing information back through us with the same program. So, we are seeing the benefits already of this program. As far as the number of cameras, that project will grow from now. We are just limited to the money we have in hand and the money the council allocates down the road. We are getting up and running. We are probably at 400+ cameras right now throughout the city. We do nothing but plan on keep on having this project to grow. The good thing is other agencies or other cities around us have looked at what we have got and are looking to do the same thing and share their information back with us. So, that will make us in the law enforcement community more connected, better connected on investigative cases. You get people who flee Jonesboro and head back to say Memphis or north or south or whatever. This technology will help keep track of those vehicles. Councilmember McClain asked, is this mainly going on SkyCops or are we talking about intersections? Chief Elliott said, It's going on our major intersections. Some of the SkyCop cameras have them. And, then our next set of fleet cameras that's coming this summer with AXON, it's going in the police cars. They will have built in LPR technology also. So, that will give every car running around on the street, they will be scanning tags and if that tag is stolen, cars stolen, or silver alert, or amber alert, or whatever, that officer will get an immediate response on his screen. And, so, this technology last year alone, we have documented 170 cases that the video analyst helped make because of the technology we have implemented. So, no sooner than we have this up and running throughout the city, it's helped us many times proven. And, just this past weekend, we had a shooting down on Roy Street and this camera technology helped locate the suspect vehicle. So, it's paying off. I think it has been a great move for the city and we are doing something that most major cities do. But, the good thing is other towns around us have come and looked at what we are doing and it has got them excited. Especially, even with a GridSmart camera. I'm kind of getting off of the subject, but Brookland has looked at GridSmart cameras for their city so what we are doing, the excitement is spreading out. So, that is a good thing for Northeast Arkansas.

Councilmember LJ Bryant asked, will the officer's cameras in the cars go backwards too like if you are looking for a blue Honda from three days ago or something? Chief Elliott said, no. In that system, they won't. We can't search that one. They just tell you what is going live and what we have put in for investigative purposes. But, I will be able to access that car, camera feed, you know, from my desk as I can the body cams now. And, that officer's camera is live and if I want to see what is going on at the scene, I can access it from my computer or any of the supervisors can. So, our technology, not only with Axon, but with Motorola and what we are doing has brought us way ahead in the world.

**A motion was made by Councilperson John Street, seconded by Councilperson LJ Bryant, that this matter be Recommended to Council . The motion PASSED with the following vote.**

**Aye:** 5 - Charles Coleman; Ann Williams; John Street; David McClain and LJ Bryant

**Absent:** 1 - Brian Emison

### RESOLUTIONS TO BE INTRODUCED

[RES-22:058](#)

RESOLUTION EXPRESSING THE WILLINGNESS OF THE CITY OF JONESBORO TO SUBMIT AN APPLICATION TO THE DEPARTMENT OF TRANSPORTATION FOR THE FY22 RAISE GRANT FOR THE UPPER HALF OF THE JONESBORO QUALITY OF LIFE AND CONNECTIVITY MASTER PLAN

*Chief Administrative Officer Brian Richardson said, I am obviously happy to discuss this further at council, but I just wanted to kind of bring the Finance Committee up to date with this. We did have our debriefing call with the Department of Transportation, I don't know, probably about a month ago when they had some recommended changes and improvements that we could make to the grant to make it or give it a better chance of being improved. We did receive high marks in several areas of our past application. And, it did qualify and it was recommended for funding, but we didn't get the highly recommended. There were over 700 grant applications sent in last year. I think that we were in the top 150 or something along those lines. I can't remember the exact number. If Regina is listening, she could correct me on that. But, they did have a lot of positives and they did see a need. They just needed to see a little bit more clarification on some of the things that we were asking for and why.*

*Councilmember David McClain asked, are they looking for as far as I guess favorability, things that make us more favorable, do they want to see a percentage of our overall plan completed or is it just shoot and see what happens? Mr. Richardson said, with any grant, the people that are offering to fund that are going to look at what have you done with past grant allocations. And this will be considered over the summer, and then as you kind of go into the fall and at that point, I think we have three right-of-ways that we are working on closing out on Creath Street and then there's some utility relocation drawings that are being worked on and so I really hope that can go to work pretty quick on that. From the city side, we are going to be funding some adjustments down Monroe to show for some pedestrian investments. So, I do think that starting to work on those projects will help with showing that we are ready to move on this. You know, it is just a struggle of having to get the right-of-ways to be able to put this through. But, I think that we are just about over that hill so we can actually get to work moving some dirt. Councilmember McClain asked, is that on Creath? I see University Heights mentioned. Is that including that or is that just on Creath as far as projects that we have got moving and actually moving dirt? Mr. Richardson said, the Creath trail will be the first one that goes to actual construction. Right now, they are beginning to do some right-of-way assessments and some environmental studies on the Aggie portion of the trail which is still not fully funded, but it's funded enough to where we can go ahead and start some of the processes of doing some of the legwork so whenever we do receive additional funding, we can hopefully move that faster to construction than anything from concept.*

*Councilmember LJ Bryant said, I know this is a bigger discussion than to have here today because there are a thousand pieces to it, but I know congressional earmarks are back. So, I'm sure you all are looking at that and such and I know everybody probably wants some money, the airport and us and everybody else so, I don't know. I'm sure you all are working on that. I know it will be difficult to come up with what our strategy, what is our ask, and I know it is not our decision to make. It is the members*

*of Congress, but, anyway, I'm sure those things are happening. I know there is a lot to discuss with all of that. Mr. Richardson said, yeah, and you don't get what you don't ask for most of the time. So, we are constantly putting in requests and asking consideration and we welcome any of those ideas from finance and from council and from the general public on the things that they would like to see.*

**A motion was made by Councilperson John Street, seconded by Councilperson LJ Bryant, that this matter be Recommended to Council . The motion PASSED with the following vote.**

**Aye:** 5 - Charles Coleman;Ann Williams;John Street;David McClain and LJ Bryant

**Absent:** 1 - Brian Emison

[RES-22:059](#)

RESOLUTION BY THE CITY COUNCIL OF THE CITY OF JONESBORO, ARKANSAS, TO PLACE A MUNICIPAL LIEN ON PROPERTY LOCATED AT 2215 Wood Street, PARCEL 01-143251-07200, JONESBORO, ARKANSAS 72401, OWNED BY INGRAM WILLA TRUST

**Attachments:** [2215 Wood](#)

**A motion was made by Councilperson John Street, seconded by Councilperson Charles Coleman, that this matter be Recommended to Council . The motion PASSED with the following vote.**

**Aye:** 5 - Charles Coleman;Ann Williams;John Street;David McClain and LJ Bryant

**Absent:** 1 - Brian Emison

[RES-22:060](#)

RESOLUTION BY THE CITY COUNCIL OF THE CITY OF JONESBORO, ARKANSAS, TO PLACE A MUNICIPAL LIEN ON PROPERTY LOCATED AT 3016 HWY 141 N, PARCEL 01-154311-00800, JONESBORO, ARKANSAS 72401, OWNED BY RKC INVESTMENTS, LLC.

**Attachments:** [3016 HWY 141 N](#)

**A motion was made by Councilperson John Street, seconded by Councilperson LJ Bryant, that this matter be Recommended to Council . The motion PASSED with the following vote.**

**Aye:** 5 - Charles Coleman;Ann Williams;John Street;David McClain and LJ Bryant

**Absent:** 1 - Brian Emison

[RES-22:061](#)

RESOLUTION AUTHORIZING THE CITY OF JONESBORO,ARKANSAS TO ENTER INTO AGREEMENT WITH THE BLUE AND YOU FOUNDATION 2022 TO RECEIVE FIVE MINI GRANTS

**A motion was made by Councilperson John Street, seconded by Councilperson Charles Coleman, that this matter be Recommended to Council . The motion PASSED with the following vote.**

**Aye:** 5 - Charles Coleman;Ann Williams;John Street;David McClain and LJ Bryant

**Absent:** 1 - Brian Emison

[RES-22:062](#)

RESOLUTION EXPRESSING THE WILLINGNESS OF THE CITY OF JONESBORO, ARKANSAS TO UTILIZE FEDERAL-AID RECREATIONAL TRAILS PROGRAM FUNDS

AND AUTHORIZING THE CITY OF JONESBORO GRANTS AND COMMUNITY DEVELOPMENT DEPARTMENT TO APPLY FOR THE FY22 RECREATIONAL TRAILS PROGRAM (RTP) FROM THE ARKANSAS DEPARTMENT OF TRANSPORTATION

*Councilmember John Street asked, Danny, is this a redo of the interior 2.3 miles around the lake? Parks and Recreation Director Danny Kapales said, yes sir. This is actually redoing the chat trail that runs along the shore line. If you haven't been out there lately, a lot of it is really low lying close to the waterway and it gets a lot of drainage and it's washed out. So, this will give us an opportunity to raise a lot of that up, put new drainage in and make that current asset that we have a much more valuable asset. Councilmember Street asked, is it going to be chat again? Mr. Kapales said, it will be. We want to keep it. Councilmember Street said, will it be smaller chat? That stuff is hard to walk on. Mr. Kapales said, along with this, we will actually go with recommendations. We will go with what is required for a soft surface trail and that way it is fitting to what the current guidelines are for a soft surface trail. Councilmember Street said, I walk it a lot. I walk the outside one too, but it is really hard and the drainage is just kind of like you and I went out there with a shovel and put a pipe in and shoveled dirt on it and it is actually humped. If we are going to do that, I would hope it would be professionally engineered where those won't wash out every time we get a heavy rain. And, at least, if it has got to be chat or some other surface that can be smaller where you can actually maybe even put some wood along the sides to contain it where it is not just going to wash off everywhere and it is really walkable because it's a shame. It is beautiful and that is why I walk it even though it's harder on my ankles and stuff. It is a beautiful trail around there. It's just so tough sometimes to walk. Mr. Kapales said, it is. And, absolutely, it is the asset out there and we want to make sure that it is a trail that everybody enjoys. And, being soft surface, that is a lot of folks want to make sure that they have a trail that is easier to walk soft surface at times. And, as long as we have a lot of it built up, as you said, a way to keep it from washing out that is what we are looking for because there are locations out there that flood. If we get a lot of heavy rain, it may be six inches of water sitting on top of some of that trail so we want to get it up and out of the water and that way you can go out there and walk right after the rain. Councilmember Street said, I think over the years, the Parks Department has probably rebuilt that thing a truck full of chat at a time going down. Mr. Kapales said, every year, we have a little bit on budget each year to put chat out there and it is just a constant refill. Councilmember Street said, I appreciate it. It is a nice trail. I love it.*

*Councilmember Ann Williams asked, on the soft surface trails, that is where mountain bikes and wider tire right or generally is that? Mr. Kapales said, soft surface just means that it is not asphalt or concrete. So, this will be for walkers. This soft surface is for walkers. Councilmember Williams said, that is what I was going to ask is there overlap between the bikers and hikers on some of these soft surface trails? Mr. Kapales said, on this trail, there won't be. This trail runs along the edge of the shoreline. This is strictly for walkers. No bikes are allowed on this section of the trail. But, as far as the overall park, we are still looking at different areas out there in the park, like this will be just for walkers. There is going to be locations out there that are going to be shared use. There are going to be locations that are just for bikers. That is one of the things that we are moving toward is how do we get the correct signage out there and make sure everybody knows what trails to be on and just make that park a little bit safer and more usable for everyone.*

*Councilmember LJ Bryant asked, if we got the grant, what do you think the timeframe is on getting this done? Mr. Kapales said, that I wish I could actually answer. Obviously, engineering is going to be the first thing. And, as Mr. Street had said, we*

*want to make sure that we do it right. So, the first phase would be the engineering process. And, I would say that is going to be at least a six month process to go in, do all of the measurements, design, and then, from there, you know, our process of getting the construction company because that is not going to be an in-house job. So, you know, at the minimum, I would say, you know, we are looking at getting this grant this year, designed through 2023. So, we are probably talking build at the end of 2023 through 2024.*

**A motion was made by Councilperson John Street, seconded by Councilperson Ann Williams, that this matter be Recommended to Council . The motion PASSED with the following vote.**

**Aye:** 5 - Charles Coleman;Ann Williams;John Street;David McClain and LJ Bryant

**Absent:** 1 - Brian Emison

**5. Pending Items**

**6. Other Business**

**7. Public Comments**

**8. Adjournment**

**A motion was made by Councilperson LJ Bryant, seconded by Councilperson John Street, that this meeting be Adjourned . The motion PASSED with the following vote.**

**Aye:** 5 - Charles Coleman;Ann Williams;John Street;David McClain and LJ Bryant

**Absent:** 1 - Brian Emison



Legislation Details (With Text)

**File #:** RES-22:068    **Version:** 1    **Name:** ENTER INTO A CONTRACT WITH WAGNER GENERAL CONTRACTORS, INC. FOR THE RENOVATIONS TO THE JONESBORO RECREATIONAL CENTER

**Type:** Resolution    **Status:** To Be Introduced

**File created:** 3/30/2022    **In control:** Finance & Administration Council Committee

**On agenda:**    **Final action:**

**Title:** A RESOLUTION OF THE CITY OF JONESBORO, ARKANSAS TO ENTER INTO A CONTRACT WITH WAGNER GENERAL CONTRACTORS, INC. FOR THE RENOVATIONS TO THE JONESBORO RECREATIONAL CENTER

**Sponsors:** Engineering, Parks & Recreation

**Indexes:** Agreement, Contract

**Code sections:**

**Attachments:** [Certified Bid Tab 03.23.22](#)  
[Agreement Jonesboro Recreational Center](#)

Date	Ver.	Action By	Action	Result
------	------	-----------	--------	--------

A RESOLUTION OF THE CITY OF JONESBORO, ARKANSAS TO ENTER INTO A CONTRACT WITH WAGNER GENERAL CONTRACTORS, INC. FOR THE RENOVATIONS TO THE JONESBORO RECREATIONAL CENTER

WHEREAS, the City of Jonesboro has desires to enter into a contract for the renovations to the Jonesboro Recreational Center;

WHEREAS, the low bidder and the firm selected for the renovations to the Jonesboro Recreational Center is Wagner General Contractors, Inc.; and,

WHEREAS, funding for the execution of the contract shall come from the American Rescue Plan Act (ARPA) funding received by the City of Jonesboro and compensation shall be paid in accordance with the agreement.

NOW, THEREFORE BE IT RESOLVED, BY THE CITY COUNCIL OF THE CITY OF JONESBORO, ARKANSAS;

Section 1: That the City of Jonesboro shall accept the low bid and enter into a contract with Wagner General Contractors, Inc. for the renovations to the Jonesboro Recreational Center.

Section 2. That funding for the execution of the contract shall come from the American Rescue Plan Act (ARPA) funding received by the City of Jonesboro and compensation shall be paid in accordance with the agreement.

Section 3. The Mayor and the City Clerk are hereby authorized by the City Council for the City of Jonesboro to execute all documents necessary to effectuate this agreement.

# Bid Opening

## BID TAB

**Date:** Wednesday, March 23, 2022 @ 2:00 p.m.  
**Project:** Renovations to  
 Jonesboro Recreation Center  
 Jonesboro, Arkansas

Contractor Name	Bid Security	Add Rc'vd	Base Bid	Completion Time	Subcontractors
<b>Olympus Construction, Inc.</b> 2506 W. Washington Ave. Jonesboro, AR 72401 Lic: 0013400123	5%	1. YES 2. YES	\$1,678,000.00	300 Days	<b>Mechanical:</b> Control Heating & Cooling, Inc. Lic: 0011640123
					<b>Plumbing:</b> PF Plumbing, LLC Lic: 0219920522
					<b>Electrical:</b> Nabco Mechanical & Electrical, Inc. Lic: 0025860422
					<b>Roofing &amp; Sheet Metal:</b> Olympus Construction, Inc. Lic: 0013400123
<b>Wagner General Contractors, Inc.</b> 600 W. Race Ave. Searcy, AR 72143 Lic: 0165491022	5%	1. YES 2. YES	\$1,630,500.00	300 Days	<b>Mechanical:</b> Cushman's Climate Control Lic: 0197850326
					<b>Plumbing:</b> Car-Son Construction LLC Lic: 0253530622
					<b>Electrical:</b> Martinez Electric, LLC Lic: 0349500322
					<b>Roofing &amp; Sheet Metal:</b> Collier Roofing, LLC Lic: 0328280322



*[Handwritten Signature]*  
 Todd Welch, AIA

# AIA® Document A101® – 2017

## **Standard Form of Agreement Between Owner and Contractor where the basis of payment is a Stipulated Sum**

**AGREEMENT** made as of the **Twenty Fourth** day of **March** in the year **2022**  
*(In words, indicate day, month and year.)*

**BETWEEN** the Owner:  
*(Name, legal status, address and other information)*

**City of Jonesboro**  
**300 South Church**  
**Jonesboro, AR 72401**

and the Contractor:  
*(Name, legal status, address and other information)*

**Wagner General Contractors, Inc.**  
**1711 Higginson Rd.**  
**Searcy, AR 72143**

for the following Project:  
*(Name, location and detailed description)*

**Renovations to Jonesboro Recreation Center – Phase II**  
**1421 West Nettleton Ave.**  
**Jonesboro, Arkansas**

The Architect:  
*(Name, legal status, address and other information)*

**Brackett-Krennerich & Associates P.A.**  
**100 E. Huntington Ave., Suite D**  
**Jonesboro, AR 72401**

The Owner and Contractor agree as follows.

**ADDITIONS AND DELETIONS:**  
The author of this document has added information needed for its completion. The author may also have revised the text of the original AIA standard form. An *Additions and Deletions Report* that notes added information as well as revisions to the standard form text is available from the author and should be reviewed. A vertical line in the left margin of this document indicates where the author has added necessary information and where the author has added to or deleted from the original AIA text.

This document has important legal consequences. Consultation with an attorney is encouraged with respect to its completion or modification.

The parties should complete A101®–2017, Exhibit A, Insurance and Bonds, contemporaneously with this Agreement. AIA Document A201®–2017, General Conditions of the Contract for Construction, is adopted in this document by reference. Do not use with other general conditions unless this document is modified.



**TABLE OF ARTICLES**

- 1 THE CONTRACT DOCUMENTS
- 2 THE WORK OF THIS CONTRACT
- 3 DATE OF COMMENCEMENT AND SUBSTANTIAL COMPLETION
- 4 CONTRACT SUM
- 5 PAYMENTS
- 6 DISPUTE RESOLUTION
- 7 TERMINATION OR SUSPENSION
- 8 MISCELLANEOUS PROVISIONS
- 9 ENUMERATION OF CONTRACT DOCUMENTS

**EXHIBIT A INSURANCE AND BONDS**

**ARTICLE 1 THE CONTRACT DOCUMENTS**

The Contract Documents consist of this Agreement, Conditions of the Contract (General, Supplementary, and other Conditions), Drawings, Specifications, Addenda issued prior to execution of this Agreement, other documents listed in this Agreement, and Modifications issued after execution of this Agreement, all of which form the Contract, and are as fully a part of the Contract as if attached to this Agreement or repeated herein. The Contract represents the entire and integrated agreement between the parties hereto and supersedes prior negotiations, representations, or agreements, either written or oral. An enumeration of the Contract Documents, other than a Modification, appears in Article 9.

**ARTICLE 2 THE WORK OF THIS CONTRACT**

The Contractor shall fully execute the Work described in the Contract Documents, except as specifically indicated in the Contract Documents to be the responsibility of others.

**ARTICLE 3 DATE OF COMMENCEMENT AND SUBSTANTIAL COMPLETION**

§ 3.1 The date of commencement of the Work shall be:

*(Check one of the following boxes.)*

- The date of this Agreement.
- A date set forth in a notice to proceed issued by the Owner.
- Established as follows:  
*(Insert a date or a means to determine the date of commencement of the Work.)*

If a date of commencement of the Work is not selected, then the date of commencement shall be the date of this Agreement.

§ 3.2 The Contract Time shall be measured from the date of commencement of the Work.

**Date of commencement to be the date of the "Notice to Proceed".**

**§ 3.3 Substantial Completion**

§ 3.3.1 Subject to adjustments of the Contract Time as provided in the Contract Documents, the Contractor shall achieve Substantial Completion of the entire Work:

*(Check one of the following boxes and complete the necessary information.)*

Init.

[ X ] Not later than **Three Hundred ( 300 )** calendar days from the date of commencement of the Work.

[ ] By the following date:

§ 3.3.2 Subject to adjustments of the Contract Time as provided in the Contract Documents, if portions of the Work are to be completed prior to Substantial Completion of the entire Work, the Contractor shall achieve Substantial Completion of such portions by the following dates:

Portion of Work	Substantial Completion Date
-----------------	-----------------------------

§ 3.3.3 If the Contractor fails to achieve Substantial Completion as provided in this Section 3.3, liquidated damages, if any, shall be assessed as set forth in Section 4.5.

#### ARTICLE 4 CONTRACT SUM

§ 4.1 The Owner shall pay the Contractor the Contract Sum in current funds for the Contractor's performance of the Contract. The Contract Sum shall be **One Million Six Hundred Thirty Thousand Five Hundred Dollars and 00/100 (\$ 1,630,500.00 )**, subject to additions and deductions as provided in the Contract Documents.

#### § 4.2 Alternates

§ 4.2.1 Alternates, if any, included in the Contract Sum:

Item	Price
------	-------

§ 4.2.2 Subject to the conditions noted below, the following alternates may be accepted by the Owner following execution of this Agreement. Upon acceptance, the Owner shall issue a Modification to this Agreement. *(Insert below each alternate and the conditions that must be met for the Owner to accept the alternate.)*

Item	Price	Conditions for Acceptance
------	-------	---------------------------

§ 4.3 Allowances, if any, included in the Contract Sum:  
*(Identify each allowance.)*

**Included in contract the stipulated sum of \$18,000.00 for potential structural modifications above and beyond those indicated on contract documents.**

Item	Price
------	-------

#### § 4.4 Unit prices, if any:

*(Identify the item and state the unit price and quantity limitations, if any, to which the unit price will be applicable.)*

Item	Units and Limitations	Price per Unit (\$0.00)
------	-----------------------	-------------------------

#### § 4.5 Liquidated damages, if any:

*(Insert terms and conditions for liquidated damages, if any.)*

**If the contractor shall fail to complete the work within the contract time, of extension of time granted by the owner, then the contractor will pay to the owner the amount of Three Hundred Dollars (\$300.00) for liquidated damages for each calendar day that the contractor shall be in default after the time stipulated in the contract documents for each phase of the work.**

#### § 4.6 Other:

Init.

AIA Document A101® – 2017. Copyright © 1915, 1918, 1925, 1937, 1951, 1958, 1961, 1963, 1967, 1974, 1977, 1987, 1991, 1997, 2007 and 2017 by The American Institute of Architects. All rights reserved. The "American Institute of Architects," "AIA," the AIA Logo, "A101," and "AIA Contract Documents" are registered trademarks and may not be used without permission. This document was produced by AIA software at 10:28:37 ET on 03/25/2022 under Order No.2114258166 which expires on 11/19/2022, is not for resale, is licensed for one-time use only, and may only be used in accordance with the AIA Contract Documents® Terms of Service. To report copyright violations, e-mail [copyright@aia.org](mailto:copyright@aia.org).

User Notes:

(1412650318)

*(Insert provisions for bonus or other incentives, if any, that might result in a change to the Contract Sum.)*

## **ARTICLE 5 PAYMENTS**

### **§ 5.1 Progress Payments**

**§ 5.1.1** Based upon Applications for Payment submitted to the Architect by the Contractor and Certificates for Payment issued by the Architect, the Owner shall make progress payments on account of the Contract Sum to the Contractor as provided below and elsewhere in the Contract Documents.

**§ 5.1.2** The period covered by each Application for Payment shall be one calendar month ending on the last day of the month, or as follows:

**§ 5.1.3** Provided that an Application for Payment is received by the Architect not later than the **Twenty-Fifth** day of a month, the Owner shall make payment of the amount certified to the Contractor not later than the **Tenth** day of the following month. If an Application for Payment is received by the Architect after the application date fixed above, payment of the amount certified shall be made by the Owner not later than **Thirty ( 30 )** days after the Architect receives the Application for Payment.

*(Federal, state or local laws may require payment within a certain period of time.)*

**§ 5.1.4** Each Application for Payment shall be based on the most recent schedule of values submitted by the Contractor in accordance with the Contract Documents. The schedule of values shall allocate the entire Contract Sum among the various portions of the Work. The schedule of values shall be prepared in such form, and supported by such data to substantiate its accuracy, as the Architect may require. This schedule of values shall be used as a basis for reviewing the Contractor's Applications for Payment.

**§ 5.1.5** Applications for Payment shall show the percentage of completion of each portion of the Work as of the end of the period covered by the Application for Payment.

**§ 5.1.6** In accordance with AIA Document A201™–2017, General Conditions of the Contract for Construction, and subject to other provisions of the Contract Documents, the amount of each progress payment shall be computed as follows:

**§ 5.1.6.1** The amount of each progress payment shall first include:

- .1 That portion of the Contract Sum properly allocable to completed Work;
- .2 That portion of the Contract Sum properly allocable to materials and equipment delivered and suitably stored at the site for subsequent incorporation in the completed construction, or, if approved in advance by the Owner, suitably stored off the site at a location agreed upon in writing; and
- .3 That portion of Construction Change Directives that the Architect determines, in the Architect's professional judgment, to be reasonably justified.

**§ 5.1.6.2** The amount of each progress payment shall then be reduced by:

- .1 The aggregate of any amounts previously paid by the Owner;
- .2 The amount, if any, for Work that remains uncorrected and for which the Architect has previously withheld a Certificate for Payment as provided in Article 9 of AIA Document A201–2017;
- .3 Any amount for which the Contractor does not intend to pay a Subcontractor or material supplier, unless the Work has been performed by others the Contractor intends to pay;
- .4 For Work performed or defects discovered since the last payment application, any amount for which the Architect may withhold payment, or nullify a Certificate of Payment in whole or in part, as provided in Article 9 of AIA Document A201–2017; and
- .5 Retainage withheld pursuant to Section 5.1.7.

### **§ 5.1.7 Retainage**

**§ 5.1.7.1** For each progress payment made prior to Substantial Completion of the Work, the Owner may withhold the following amount, as retainage, from the payment otherwise due:

Init.

**AIA Document A101® – 2017.** Copyright © 1915, 1918, 1925, 1937, 1951, 1958, 1961, 1963, 1967, 1974, 1977, 1987, 1991, 1997, 2007 and 2017 by The American Institute of Architects. All rights reserved. The "American Institute of Architects," "AIA," the AIA Logo, "A101," and "AIA Contract Documents" are registered trademarks and may not be used without permission. This document was produced by AIA software at 10:28:37 ET on 03/25/2022 under Order No.2114258166 which expires on 11/19/2022, is not for resale, is licensed for one-time use only, and may only be used in accordance with the AIA Contract Documents® Terms of Service. To report copyright violations, e-mail [copyright@aia.org](mailto:copyright@aia.org).

User Notes:

(1412650318)

*(Insert a percentage or amount to be withheld as retainage from each Application for Payment. The amount of retainage may be limited by governing law.)*

#### **Five Percent (5%)**

§ 5.1.7.1.1 The following items are not subject to retainage:

*(Insert any items not subject to the withholding of retainage, such as general conditions, insurance, etc.)*

#### **Insurance, Building Permit, and Fees**

§ 5.1.7.2 Reduction or limitation of retainage, if any, shall be as follows:

*(If the retainage established in Section 5.1.7.1 is to be modified prior to Substantial Completion of the entire Work, including modifications for Substantial Completion of portions of the Work as provided in Section 3.3.2, insert provisions for such modifications.)*

§ 5.1.7.3 Except as set forth in this Section 5.1.7.3, upon Substantial Completion of the Work, the Contractor may submit an Application for Payment that includes the retainage withheld from prior Applications for Payment pursuant to this Section 5.1.7. The Application for Payment submitted at Substantial Completion shall not include retainage as follows:

*(Insert any other conditions for release of retainage upon Substantial Completion.)*

**Retainage will be withheld in the amount equal to work left to complete at substantial completion; as determined by the Architect.**

§ 5.1.8 If final completion of the Work is materially delayed through no fault of the Contractor, the Owner shall pay the Contractor any additional amounts in accordance with Article 9 of AIA Document A201–2017.

§ 5.1.9 Except with the Owner’s prior approval, the Contractor shall not make advance payments to suppliers for materials or equipment which have not been delivered and stored at the site.

#### **§ 5.2 Final Payment**

§ 5.2.1 Final payment, constituting the entire unpaid balance of the Contract Sum, shall be made by the Owner to the Contractor when

- .1 the Contractor has fully performed the Contract except for the Contractor’s responsibility to correct Work as provided in Article 12 of AIA Document A201–2017, and to satisfy other requirements, if any, which extend beyond final payment; and
- .2 a final Certificate for Payment has been issued by the Architect.

§ 5.2.2 The Owner’s final payment to the Contractor shall be made no later than 30 days after the issuance of the Architect’s final Certificate for Payment, or as follows:

**Provided final certificate of payment is accompanied with all of the closeout and final documents as required by the specifications.**

#### **§ 5.3 Interest**

Payments due and unpaid under the Contract shall bear interest from the date payment is due at the rate stated below, or in the absence thereof, at the legal rate prevailing from time to time at the place where the Project is located.

*(Insert rate of interest agreed upon, if any.)*

%

### **ARTICLE 6 DISPUTE RESOLUTION**

#### **§ 6.1 Initial Decision Maker**

The Architect will serve as the Initial Decision Maker pursuant to Article 15 of AIA Document A201–2017, unless the parties appoint below another individual, not a party to this Agreement, to serve as the Initial Decision Maker.

Init.

AIA Document A101® – 2017. Copyright © 1915, 1918, 1925, 1937, 1951, 1958, 1961, 1963, 1967, 1974, 1977, 1987, 1991, 1997, 2007 and 2017 by The American Institute of Architects. All rights reserved. The “American Institute of Architects,” “AIA,” the AIA Logo, “A101,” and “AIA Contract Documents” are registered trademarks and may not be used without permission. This document was produced by AIA software at 10:28:37 ET on 03/25/2022 under Order No.2114258166 which expires on 11/19/2022, is not for resale, is licensed for one-time use only, and may only be used in accordance with the AIA Contract Documents® Terms of Service. To report copyright violations, e-mail [copyright@aia.org](mailto:copyright@aia.org).

User Notes:

(1412650318)

*(If the parties mutually agree, insert the name, address and other contact information of the Initial Decision Maker, if other than the Architect.)*

**§ 6.2 Binding Dispute Resolution**

For any Claim subject to, but not resolved by, mediation pursuant to Article 15 of AIA Document A201–2017, the method of binding dispute resolution shall be as follows:

*(Check the appropriate box.)*

- Arbitration pursuant to Section 15.4 of AIA Document A201–2017
- Litigation in a court of competent jurisdiction
- Other *(Specify)*

If the Owner and Contractor do not select a method of binding dispute resolution, or do not subsequently agree in writing to a binding dispute resolution method other than litigation, Claims will be resolved by litigation in a court of competent jurisdiction.

**ARTICLE 7 TERMINATION OR SUSPENSION**

**§ 7.1** The Contract may be terminated by the Owner or the Contractor as provided in Article 14 of AIA Document A201–2017.

**§ 7.1.1** If the Contract is terminated for the Owner’s convenience in accordance with Article 14 of AIA Document A201–2017, then the Owner shall pay the Contractor a termination fee as follows:

*(Insert the amount of, or method for determining, the fee, if any, payable to the Contractor following a termination for the Owner’s convenience.)*

**§ 7.2** The Work may be suspended by the Owner as provided in Article 14 of AIA Document A201–2017.

**ARTICLE 8 MISCELLANEOUS PROVISIONS**

**§ 8.1** Where reference is made in this Agreement to a provision of AIA Document A201–2017 or another Contract Document, the reference refers to that provision as amended or supplemented by other provisions of the Contract Documents.

**§ 8.2** The Owner’s representative:

*(Name, address, email address, and other information)*

**Craig Light**  
**Engineering Director – City of Jonesboro**  
**300 South Church St.**  
**Jonesboro, AR 72401**  
**(870) 932-2438**

**§ 8.3** The Contractor’s representative:

*(Name, address, email address, and other information)*

**Shelton Allen Wagner, Jr.**  
**President – Wagner General Contractors, Inc.**  
**1711 Higginson Rd.**  
**Searcy, AR 72143**  
**(501) 203-0704**

init.



§ 8.4 Neither the Owner's nor the Contractor's representative shall be changed without ten days' prior notice to the other party.

**§ 8.5 Insurance and Bonds**

§ 8.5.1 The Owner and the Contractor shall purchase and maintain insurance as set forth in AIA Document A101™-2017, Standard Form of Agreement Between Owner and Contractor where the basis of payment is a Stipulated Sum, Exhibit A, Insurance and Bonds, and elsewhere in the Contract Documents.

§ 8.5.2 The Contractor shall provide bonds as set forth in AIA Document A101™-2017 Exhibit A, and elsewhere in the Contract Documents.

§ 8.6 Notice in electronic format, pursuant to Article 1 of AIA Document A201-2017, may be given in accordance with AIA Document E203™-2013, Building Information Modeling and Digital Data Exhibit, if completed, or as otherwise set forth below:

*(If other than in accordance with AIA Document E203-2013, insert requirements for delivering notice in electronic format such as name, title, and email address of the recipient and whether and how the system will be required to generate a read receipt for the transmission.)*

§ 8.7 Other provisions:

**ARTICLE 9 ENUMERATION OF CONTRACT DOCUMENTS**

§ 9.1 This Agreement is comprised of the following documents:

- .1 AIA Document A101™-2017, Standard Form of Agreement Between Owner and Contractor
- .2 AIA Document A101™-2017, Exhibit A, Insurance and Bonds
- .3 AIA Document A201™-2017, General Conditions of the Contract for Construction
- .4 AIA Document E203™-2013, Building Information Modeling and Digital Data Exhibit, dated as indicated below:  
*(Insert the date of the E203-2013 incorporated into this Agreement.)*

- .5 Drawings

Entitled "Renovations to Jonesboro Recreational Center – Phase II, Jonesboro, Arkansas" and bear the Architect's commission number 2127. See attached Exhibit "A".

Number	Title	Date
--------	-------	------

- .6 Specifications

Entitled "Renovations to Jonesboro Recreational Center – Phase II, Jonesboro, Arkansas" and bear the Architect's commission number 2127. See attached Exhibit "B".

Section	Title	Date	Pages
---------	-------	------	-------

- .7 Addenda, if any:

Number	Date	Pages
Addenda No. 1	March 15, 2022	(14) Forteen Pages
Addenda No. 2	March 16, 2022	(11) Eleven Pages
See attached Exhibit "C"		

Init.

Portions of Addenda relating to bidding or proposal requirements are not part of the Contract Documents unless the bidding or proposal requirements are also enumerated in this Article 9.

**.8 Other Exhibits:**

*(Check all boxes that apply and include appropriate information identifying the exhibit where required.)*

AIA Document E204™–2017, Sustainable Projects Exhibit, dated as indicated below:  
*(Insert the date of the E204-2017 incorporated into this Agreement.)*

The Sustainability Plan:

Title	Date	Pages
-------	------	-------

Supplementary and other Conditions of the Contract:

Document	Title	Date	Pages
----------	-------	------	-------

**.9 Other documents, if any, listed below:**

*(List here any additional documents that are intended to form part of the Contract Documents. AIA Document A201™–2017 provides that the advertisement or invitation to bid, Instructions to Bidders, sample forms, the Contractor's bid or proposal, portions of Addenda relating to bidding or proposal requirements, and other information furnished by the Owner in anticipation of receiving bids or proposals, are not part of the Contract Documents unless enumerated in this Agreement. Any such documents should be listed here only if intended to be part of the Contract Documents.)*

1. **Exhibit "A" – Enumeration of the Contract Documents – Drawings**
2. **Exhibit "B" – Enumeration of the Contract Documents – Specifications**
3. **Exhibit "C" – Enumeration of the Contract Documents – Addenda**
4. **Advertisement for Bids**
5. **Contractor's Bid and Bid Bond**
6. **Certified Bid Tabulation**
7. **Certificate(s) of Insurance**
8. **Payment and Performance Bonds (filed/recorded in Craighead County)**
9. **Contractor's Affidavit of Payment of Debts and Claims (required at close-out)**
10. **Contractor's Release of Liens (required at close-out)**
11. **Consent of Surety to Final Payment (required at close-out)**

This Agreement entered into as of the day and year first written above.

\_\_\_\_\_  
**OWNER (Signature)**

**Harold Copenhaver, Mayor**  
*(Printed name and title)*

\_\_\_\_\_  
**CONTRACTOR (Signature)**

**Shelton Allen Wagner, Jr., President**  
*(Printed name and title)*

Init.

**AIA Document A101® – 2017.** Copyright © 1915, 1918, 1925, 1937, 1951, 1958, 1961, 1963, 1967, 1974, 1977, 1987, 1991, 1997, 2007 and 2017 by The American Institute of Architects. All rights reserved. The "American Institute of Architects," "AIA," the AIA Logo, "A101," and "AIA Contract Documents" are registered trademarks and may not be used without permission. This document was produced by AIA software at 10:28:37 ET on 03/25/2022 under Order No.2114258166 which expires on 11/19/2022, is not for resale, is licensed for one-time use only, and may only be used in accordance with the AIA Contract Documents® Terms of Service. To report copyright violations, e-mail [copyright@aia.org](mailto:copyright@aia.org).

**User Notes:**

(1412650318)

**SECTION 00 0115**  
**LIST OF DRAWING SHEETS**

**THE FOLLOWING DRAWINGS DATED FEBRUARY 20, 2022 BEARING THE ARCHITECT'S COMMISSION NUMBER 2127 WITH THESE SPECIFICATIONS FORM THE CONTRACT DOCUMENTS.**

**CIVIL**

C001 ..... SITE PLAN &amp; DETAILS

**LIFE SAFETY**

LS001 ..... LIFE SAFETY

**DEMOLITION**

D100 ..... FIRST &amp; SECOND FLOOR DEMOLITION PLAN

**ARCHITECTURAL**

A001 ..... DOOR SCHEDULE, VISUAL DOOR FRAMES, AND FRAME DETAILS

A002 ..... FINISH FLOOR PLAN AND SCHEDULE

A100 ..... FIRST FLOOR PLAN, SECOND FLOOR PLAN

A101 ..... VISUAL WALL TYPES AND PLAN DETAILS

A200 ..... BUILDING ELEVATIONS

A201 ..... BUILDING SECTIONS

A400 ..... REFLECTED CEILING PLANS, CEILING DETAILS

A500 ..... WALL SECTIONS

A600 ..... TOILET MOUNTING HEIGHTS AND DETAILS

A601 ..... ENLARGED TOILET PLAN, TOILET ELEVATIONS, DETAILS, MILLWORK &  
MILLWORK SECTIONS

A700 ..... INTERIOR ELEVATIONS

**STRUCTURAL**

S100 ..... PLAN AND DETIALS

**MECHANICAL**

M001 ..... GENERAL NOTES AND LEGENDS

M101 ..... HVAC PLAN - DEMO

M201 ..... HVAC PLAN - NEW

M301 ..... HVAC SECTIONS

M501 ..... HVAC DETAILS

M502 ..... HVAC DETAILS

M601 ..... HVAC SCHEDULES

**PLUMBING**

P001 ..... GENERAL NOTES AND LEGENDS

P101 ..... PLUMBING PLAN - DEMO

P201 ..... PLUMBING PLAN - NEW

P202 ..... SEWER PLAN - NEW

P501 ..... PLUMBING DETAILS

P601 ..... PLUMBING SCHEDULES

P602 ..... PLUMBING RISERS

P603 ..... PLUMBING RISERS



**FIRE PROTECTION**

F100..... FIRE PROTECTION SITE PLAN  
F101..... FIRE PROTECTION PLAN  
F501..... FIRE SUPPRESSION DETAILS  
F502..... FIRE SUPPRESSION DETAILS

**ELECTRICAL**

E100 ..... GENERAL NOTES AND LEGENDS  
E101 ..... ELECTRICAL REFLECTED CEILING PLAN - DEMO  
E102 ..... ELECTRICAL PLAN - DEMO  
E103 ..... ELECTRICAL REFLECTED CEILING PLAN - NEW  
E104 ..... ELECTRICAL PLAN - NEW  
E105 ..... FIRE ALARM PLAN  
E501 ..... ELECTRICAL DETAILS  
E601 ..... ELECTRICAL SCHEDULES  
E602 ..... ELECTRICAL RISER DIAGRAM

***End of List of Drawings***

**SECTION 00 0110**

**TABLE OF CONTENTS**

**INTRODUCTORY INFORMATION**

00 0101	PROJECT TITLE .....	1
00 0110	TABLE OF CONTENTS .....	6
00 0115	LIST OF DRAWING SHEETS .....	2

**PROCUREMENT REQUIREMENTS**

00 1113	ADVERTISEMENT FOR BIDS .....	1
00 2100	INSTRUCTIONS TO BIDDERS .....	7
00 4100	BID FORM .....	2

**CONTRACTING REQUIREMENTS**

00 5200	AGREEMENT FORM .....	9
---------	----------------------	---

**DESIGN CRITERIA**

00 6000	PROJECT FORMS .....	11
00 7200	GENERAL CONDITIONS .....	41
00 7300	SUPPLEMENTARY CONDITIONS .....	6

**SUMMARY**

01 1100	SUMMARY OF THE WORK .....	2
01 1115	ITEMS FURNISHED BY OWNER .....	1

**PRICE AND PAYMENT PROCEDURES**

01 2100	ALLOWANCES .....	1
01 2973	SCHEDULE OF VALUES .....	2
01 2976	PROGRESS PAYMENT PROCEDURES .....	1

**ADMINISTRATIVE REQUIREMENTS**

01 3113	COORDINATION .....	1
01 3119	PROJECT MEETINGS .....	2
01 3216	CONSTRUCTION SCHEDULES .....	1
01 3223	SURVEY AND LAYOUT DATA .....	1
01 3323	SUBMITTALS .....	4

**QUALITY REQUIREMENTS**

01 4000	QUALITY REQUIREMENTS	.....	4
---------	----------------------	-------	---

**TEMPORARY FACILITIES AND CONTROLS**

01 5000	TEMPORARY FACILITIES AND CONTROLS	....	1
01 5710	EXCAVATION SAFETY PROCEDURES	.....	1
01 5713	TEMPORARY EROSION CONTROL	.....	2
01 5719	ENVIRONMENT PROTECTION	....	2

**PRODUCT REQUIREMENTS**

01 6000	PRODUCT REQUIREMENTS	.....	2
01 6300	PRODUCT OPTIONS AND SUBSTITUTIONS	.....	4

**EXECUTION AND CLOSEOUT REQUIREMENTS**

01 7300	EXECUTION REQUIREMENTS	.....	1
01 7329	CUTTING AND PATCHING	.....	2
01 7400	CLEANING	.....	1
01 7700	CLOSEOUT PROCEDURES	.....	1
01 7800	CLOSE-OUT SUBMITTALS	.....	3
01 7839	PROJECT RECORD DOCUMENTS	.....	1

**DIVISION 02 - DEMOLITION**

02 4100	SELECTIVE DEMOLITION	.....	4
---------	----------------------	-------	---

**DIVISION 03 - CONCRETE**

03 3000	CAST-IN-PLACE CONCRETE	.....	8
---------	------------------------	-------	---

**DIVISION 04 - MASONRY**

04 0511	MASONRY MORTARING AND GROUTING	.....	3
04 2000	UNIT MASONRY	.....	5

**DIVISION 05 – METALS**

05 1200	STRUCTURAL STEEL FRAMING	.....	4
05 5000	METAL FABRICATIONS	.....	3
05 7501	DECORATIVE METAL FABRIC	.....	1

**DIVISION 06 – WOOD, PLASTICS, AND COMPOSITES**

06 1000	ROUGH CARPENTRY	.....	2
06 2000	FINISH CARPENTRY	.....	2
06 4116	LAMINATE CLAD MILLWORK	.....	4
06 4117	CABINET HARDWARE	.....	2
06 6116	SOLID SURFACING FABRICATIONS	.....	2

**DIVISION 07 – THERMAL AND MOISTURE PROTECTION**

07 2116	BLANKET INSULATION	.....	1
07 2600	VAPOR RETARDERS	.....	2
07 9005	JOINT SEALERS	.....	4

**DIVISION 08 – OPENINGS**

08 1113	HOLLOW METAL DOORS AND FRAMES	.....	3
08 1416	FLUSH WOOD DOORS	.....	3
08 1430	PRE-HUNG DOOR UNITS	.....	2
08 7100	DOOR HARDWARE	.....	6
08 8000	GLAZING	.....	4

**DIVISION 09 – FINISHES**

09 2116	GYPSUM BOARD ASSEMBLIES	.....	4
09 3000	TILING	.....	3
09 5100	ACOUSTICAL CEILINGS	.....	4
09 6250	RESILIENT SPORTS FLOOR	.....	3
09 6500	RESILIENT FLOORING	.....	3
09 6700	EPOXY WAINSCOT	.....	3
09 6800	CARPETING	.....	2
09 9000	PAINTING AND COATING	.....	6
09 9656	EPOXY COATINGS	.....	2
09 9667	ACRYLIC COATING	.....	3

**DIVISION 10 – SPECIALTIES**

10 1425	SIGNAGE	.....	2
10 2113	PLASTIC TOILET COMPARTMENTS	.....	2
10 2813	TOILET ACCESSORIES	.....	4
10 4400	FIRE PROTECTION SPECIALTIES	.....	2
10 7316	PRE-MANUFACTURED CANOPIES	.....	2

**DIVISION 11 – EQUIPMENT**

11 3100	RESIDENTIAL APPLIANCES	.....	2
11 6600	ATHLETIC EQUIPMENT	.....	6

**DIVISION 32 – EXTERIOR IMPROVEMENTS**

32 1313	CONCRETE PAVING	.....	4
32 1813	SYNTHETIC TURF	.....	5
32 3126	CHAIN LINK FENCES AND GATES	.....	5
32 9213	HYDROMULCHING	.....	3

**END OF SECTION**

**Jonesboro Recreation Center  
Commission Number: 2127  
Jonesboro, Arkansas**

**Garver Project # 21B00540**

**February 21, 2022**

**TABLE OF CONTENTS**

**DIVISION 21 – FIRE PROTECTION**

Section 21 05 29	Hangers and Supports for Fire Suppression Piping and Equipment
Section 21 05 53	Identification for Fire-Suppression Piping and Equipment
Section 21 13 13	Wet-Pipe Sprinkler Systems

**DIVISION 22 – PLUMBING**

Section 22 11 16	Domestic Water Piping
Section 22 11 19	Domestic Water Piping Specialties
Section 22 13 16	Sanitary Sewer Piping
Section 22 42 13	Plumbing Fixtures

**DIVISION 23 – HEATING, VENTILATING, AND AIR-CONDITIONING (HVAC)**

Section 23 05 93	Testing, Adjusting, and Balancing
Section 23 07 00	HVAC Insulation
Section 23 23 00	Refrigerant Piping
Section 23 31 13	Metal Ducts
Section 23 34 16	Centrifugal HVAC Fans
Section 23 37 13	Diffusers, Registers, and Grilles
Section 23 37 16	Fabric Air-Distribution Devices
Section 23 37 23	HVAC Gravity Ventilators
Section 23 74 16.13	Packaged Rooftop Air Conditioning Units
Section 23 81 26	Split-system Air Conditioners
Section 23 82 39.13	Cabinet Unit Heaters

**DIVISION 26 – ELECTRICAL**

Section 26 05 19	Low-Voltage Electrical Power Conductors and Cables
Section 26 05 26	Grounding and Bonding for Electrical Systems
Section 26 05 29	Hangers and Supports for Electrical Systems
Section 26 05 33	Raceways and Boxes for Electrical Systems
Section 26 05 44	Sleeves and Sleeve Seals for Electrical Raceways and Cabling
Section 26 05 48.16	Seismic Controls for Electrical Systems
Section 26 05 53	Identification for Electrical Systems
Section 26 09 23	Lighting Control Devices
Section 26 24 16	Panelboards
Section 26 27 26	Wiring Devices
Section 26 28 16	Enclosed Switches and Circuit Breakers
Section 26 43 13	Surge Protection for Low-Voltage Electrical Power Circuits

Section 26 51 19 LED Interior Lighting  
Section 26 52 13 Emergency and Exit Lighting

**DIVISION 27 – COMMUNICATIONS**

Section 27 05 26 Grounding and Bonding for Communications  
Section 27 05 28 Pathways for Communications Systems  
Section 27 05 29 Hangers and Supports for Communications Systems  
Section 27 05 48.16 Seismic Control for Communications Systems  
Section 27 05 53 Identification for Communications Systems  
Section 27 15 13 Communications Copper Horizontal Cabling

**DIVISION 28 – ELECTRONIC SAFETY AND SECURITY**

Section 28 31 11 Digital, Addressable Fire-Alarm System

ADDENDUM NO. 1

PROJECT TITLE: Renovations to  
Jonesboro Recreation Center – Phase II  
Jonesboro, Arkansas

OWNER: City of Jonesboro  
300 S. Church St.  
Jonesboro, AR 72401

OWNER'S REPRESENTATIVE: Honorable Mayor Harold Copenhaver  
(870) 932-1052 Office

ARCHITECT: Brackett-Krennerich and Associates P.A.  
100 East Huntington Avenue, Suite D  
Post Office Box 1655  
Jonesboro, Arkansas 72403-1655  
(870) 932-0571 *office*

COMMISSION NUMBER: 2127

DATE OF ISSUE: March 15, 2022

BID DATE/LOCATION: **March 23, 2022 at 2:00 p.m.** C.D.S.T  
1<sup>st</sup> Floor Conference Room at the Municipal Building Center  
300 S. Church St.  
Jonesboro, AR 72401

---

---

Contractor shall take note of the following listed revisions and/or additions to the drawings and specifications for the above referenced project and adjust the contract sum accordingly. These revisions are hereby made a part of said documents and subsequent construction as if therein included.



---

*GENERAL*

---

1. Specifications: Section 00 7301 – FEDERAL REGULATIONS
  - A. Add Section 00 7301 – FEDERAL REGULATIONS; Refer to Page 3-10 of this Addendum.
  
2. Specifications: Section 00 4100 – BID FORM
  - A. Refer to Page 11-14; Exhibit “A” and Exhibit “B” must be certified and turned in with bid form at time of bid.
  
3. General: SAM.GOV REGISTRATION
  - A. Contractors who enter into a contract with The City of Jonesboro must be registered with SAM.GOV.

**SECTION 00 7301  
FEDERAL REGULATIONS**

**PART 1 GENERAL**

**1.01 CARES ACT**

- A. Funding in part for this project is provided by grant funding established by the Cares Act.
- B. The Davis - Bacon Act applies to contractors and subcontractors performing work on this project.
- C. Federal Wage Rates apply to this project. Wage decision number AR20220024 is included at the end of this section.
- D. Payroll Reporting Forms must be used by contractors and subcontractors.

**1.02 DAVIS-BACON ACT**

- A. The following contract clauses from The Davis-Bacon Act are included in these specifications as required by The Cares Act.
- B. Federal Wage Rate is included.

**END OF SECTION**

"General Decision Number: AR20220024 02/25/2022

Superseded General Decision Number: AR20210024

State: Arkansas

Construction Type: Building

BUILDING CONSTRUCTION PROJECTS (does not include single family homes or apartments up to and including 4 stories).

County: Craighead County in Arkansas.

Note: Contracts subject to the Davis-Bacon Act are generally required to pay at least the applicable minimum wage rate required under Executive Order 14026 or Executive Order 13658. Please note that these Executive Orders apply to covered contracts entered into by the federal government that are subject to the Davis-Bacon Act itself, but do not apply to contracts subject only to the Davis-Bacon Related Acts, including those set forth at 29 CFR 5.1(a)(2)-(60).

If the contract is entered into on or after January 30, 2022, or the contract is renewed or extended (e.g., an option is exercised) on or after January 30, 2022:	<ul style="list-style-type: none"><li>. Executive Order 14026 generally applies to the contract.</li><li>. The contractor must pay all covered workers at least \$15.00 per hour (or the applicable wage rate listed on this wage determination, if it is higher) for all hours spent performing on the contract in 2022.</li></ul>
If the contract was awarded on or between January 1, 2015 and January 29, 2022, and the contract is not renewed or extended on or after January 30, 2022:	<ul style="list-style-type: none"><li>. Executive Order 13658 generally applies to the contract.</li><li>. The contractor must pay all covered workers at least \$11.25 per hour (or the applicable wage rate listed on this wage determination, if it is higher) for all hours spent performing on that contract in 2022.</li></ul>

The applicable Executive Order minimum wage rate will be

adjusted annually. If this contract is covered by one of the Executive Orders and a classification considered necessary for performance of work on the contract does not appear on this wage determination, the contractor must still submit a conformance request.

Additional information on contractor requirements and worker protections under the Executive Orders is available at <https://www.dol.gov/agencies/whd/government-contracts>.

Modification Number	Publication Date
0	01/07/2022
1	02/25/2022

BOIL0069-002 01/01/2021

	Rates	Fringes
BOILERMAKER.....	\$ 30.49	23.13

PAIN0424-009 07/01/2021

	Rates	Fringes
PAINTER (Brush, Roller and Spray).....	\$ 16.25	10.42

PLUM0155-015 08/01/2021

	Rates	Fringes
PIPEFITTER.....	\$ 25.91	11.77

SHEE0036-034 06/01/2021

	Rates	Fringes
SHEET METAL WORKER (Includes HVAC Duct Installation).....	\$ 24.44	13.66

\* SUAR2015-021 01/09/2017

	Rates	Fringes
BRICKLAYER.....	\$ 19.39	0.00
CARPENTER.....	\$ 17.73	3.31
CEMENT MASON/CONCRETE FINISHER...	\$ 17.03	0.00

ELECTRICIAN.....	\$ 18.69	4.17
INSULATOR - MECHANICAL (Duct, Pipe & Mechanical System Insulation).....		
	\$ 17.16	4.76
IRONWORKER, REINFORCING.....	\$ 14.00 **	0.00
IRONWORKER, STRUCTURAL.....	\$ 19.39	0.00
LABORER: Common or General.....	\$ 10.61 **	0.00
LABORER: Mason Tender - Brick...	\$ 12.04 **	0.00
LABORER: Pipelayer.....	\$ 14.02 **	0.00
OPERATOR:		
Backhoe/Excavator/Trackhoe.....	\$ 22.75	0.00
OPERATOR: Bulldozer.....	\$ 15.88	0.00
OPERATOR: Crane.....	\$ 17.52	0.00
OPERATOR: Grader/Blade.....	\$ 14.66 **	0.00
OPERATOR: Paver (Asphalt, Aggregate, and Concrete).....	\$ 17.79	0.00
OPERATOR: Roller.....	\$ 14.34 **	0.00
PLUMBER.....	\$ 21.26	4.20
ROOFER.....	\$ 15.39	0.00
TRUCK DRIVER: Dump Truck.....	\$ 13.54 **	0.23

-----  
 WELDERS - Receive rate prescribed for craft performing  
 operation to which welding is incidental.

=====  
 \*\* Workers in this classification may be entitled to a higher  
 minimum wage under Executive Order 14026 (\$15.00) or 13658  
 (\$11.25). Please see the Note at the top of the wage  
 determination for more information.

Note: Executive Order (EO) 13706, Establishing Paid Sick Leave  
 for Federal Contractors applies to all contracts subject to the

Davis-Bacon Act for which the contract is awarded (and any solicitation was issued) on or after January 1, 2017. If this contract is covered by the EO, the contractor must provide employees with 1 hour of paid sick leave for every 30 hours they work, up to 56 hours of paid sick leave each year. Employees must be permitted to use paid sick leave for their own illness, injury or other health-related needs, including preventive care; to assist a family member (or person who is like family to the employee) who is ill, injured, or has other health-related needs, including preventive care; or for reasons resulting from, or to assist a family member (or person who is like family to the employee) who is a victim of, domestic violence, sexual assault, or stalking. Additional information on contractor requirements and worker protections under the EO is available at <https://www.dol.gov/agencies/whd/government-contracts>.

Unlisted classifications needed for work not included within the scope of the classifications listed may be added after award only as provided in the labor standards contract clauses (29CFR 5.5 (a) (1) (ii)).

-----

The body of each wage determination lists the classification and wage rates that have been found to be prevailing for the cited type(s) of construction in the area covered by the wage determination. The classifications are listed in alphabetical order of ""identifiers"" that indicate whether the particular rate is a union rate (current union negotiated rate for local), a survey rate (weighted average rate) or a union average rate (weighted union average rate).

#### Union Rate Identifiers

A four letter classification abbreviation identifier enclosed in dotted lines beginning with characters other than ""SU"" or ""UAVG"" denotes that the union classification and rate were prevailing for that classification in the survey. Example: PLUM0198-005 07/01/2014. PLUM is an abbreviation identifier of the union which prevailed in the survey for this classification, which in this example would be Plumbers. 0198 indicates the local union number or district council number where applicable, i.e., Plumbers Local 0198. The next number, 005 in the example, is an internal number used in processing the wage determination. 07/01/2014 is the effective date of the most current negotiated rate, which in this example is July 1, 2014.

Union prevailing wage rates are updated to reflect all rate changes in the collective bargaining agreement (CBA) governing this classification and rate.

#### Survey Rate Identifiers

Classifications listed under the "SU" identifier indicate that no one rate prevailed for this classification in the survey and the published rate is derived by computing a weighted average rate based on all the rates reported in the survey for that classification. As this weighted average rate includes all rates reported in the survey, it may include both union and non-union rates. Example: SULA2012-007 5/13/2014. SU indicates the rates are survey rates based on a weighted average calculation of rates and are not majority rates. LA indicates the State of Louisiana. 2012 is the year of survey on which these classifications and rates are based. The next number, 007 in the example, is an internal number used in producing the wage determination. 5/13/2014 indicates the survey completion date for the classifications and rates under that identifier.

Survey wage rates are not updated and remain in effect until a new survey is conducted.

#### Union Average Rate Identifiers

Classification(s) listed under the UAVG identifier indicate that no single majority rate prevailed for those classifications; however, 100% of the data reported for the classifications was union data. EXAMPLE: UAVG-OH-0010 08/29/2014. UAVG indicates that the rate is a weighted union average rate. OH indicates the state. The next number, 0010 in the example, is an internal number used in producing the wage determination. 08/29/2014 indicates the survey completion date for the classifications and rates under that identifier.

A UAVG rate will be updated once a year, usually in January of each year, to reflect a weighted average of the current negotiated/CBA rate of the union locals from which the rate is based.

---

#### WAGE DETERMINATION APPEALS PROCESS

1.) Has there been an initial decision in the matter? This can be:

- \* an existing published wage determination
- \* a survey underlying a wage determination
- \* a Wage and Hour Division letter setting forth a position on a wage determination matter
- \* a conformance (additional classification and rate) ruling

On survey related matters, initial contact, including requests for summaries of surveys, should be with the Wage and Hour National Office because National Office has responsibility for the Davis-Bacon survey program. If the response from this initial contact is not satisfactory, then the process described in 2.) and 3.) should be followed.

With regard to any other matter not yet ripe for the formal process described here, initial contact should be with the Branch of Construction Wage Determinations. Write to:

Branch of Construction Wage Determinations  
Wage and Hour Division  
U.S. Department of Labor  
200 Constitution Avenue, N.W.  
Washington, DC 20210

2.) If the answer to the question in 1.) is yes, then an interested party (those affected by the action) can request review and reconsideration from the Wage and Hour Administrator (See 29 CFR Part 1.8 and 29 CFR Part 7). Write to:

Wage and Hour Administrator  
U.S. Department of Labor  
200 Constitution Avenue, N.W.  
Washington, DC 20210

The request should be accompanied by a full statement of the interested party's position and by any information (wage payment data, project description, area practice material, etc.) that the requestor considers relevant to the issue.

3.) If the decision of the Administrator is not favorable, an interested party may appeal directly to the Administrative Review Board (formerly the Wage Appeals Board). Write to:

Administrative Review Board  
U.S. Department of Labor  
200 Constitution Avenue, N.W.  
Washington, DC 20210

4.) All decisions by the Administrative Review Board are final.





END OF GENERAL DECISION"

**NON-COLLUSION AFFIDAVIT**

**EXHIBIT "A"**

State of \_\_\_\_\_

Bid # \_\_\_\_\_

County of \_\_\_\_\_

I state that I am \_\_\_\_\_ of \_\_\_\_\_  
(Title) (Name of my firm)

and that I am authorized to make this affidavit on behalf of my firm, and its owners, directors, and officers. I am the person responsible in my firm for the price(s) and the amount of this bid.

I state that:

- 1) The price(s) and amount of this bid have been arrived at independently and without consultation, communication or agreement with any other contractor, bidder or potential bidder.
- 2) Neither the price(s) nor the amount of this bid, and neither the approximate price(s) nor approximate amount of this bid, have been disclosed to any other firm or person who is a bidder or potential bidder and they will not be discussed before bid opening.
- 3) No attempt has been made or will be made to induce any firm or person to refrain from bidding on this contract, or to submit a bid higher than this bid, or to submit any intentionally high or noncompetitive bid or other form of complementary bid.
- 4) The bid of my firm is made in good faith and not pursuant to any agreement or discussion with, or inducement from, any firm or person to submit a complementary or other noncompetitive bid.
- 5) \_\_\_\_\_ its affiliates, subsidiaries, officers directors  
(Name of Firm)  
and employees are not currently under investigation by any governmental agency and have not in the last four years been convicted or found liable for any act prohibited by State or Federal law in any jurisdiction, involving conspiracy or collusion with respect to bidding on any public contract, except as follows:

I state that \_\_\_\_\_ understands and acknowledges that the  
(Name of Firm)  
above representations are material and important and will be relied on by \_\_\_\_\_  
(Name of Public Entity)  
in awarding the contract(s) for which this bid is submitted. I understand that my firm understands that any misstatement in this affidavit is and shall be treated as fraudulent concealment from \_\_\_\_\_  
(Name of Public Entity)  
of the true facts relating to the submission for this contract.

\_\_\_\_\_  
(Name and Company Position)

SWORN TO AND SUBSCRIBED  
BEFORE ME THIS \_\_\_\_\_ DAY  
OF \_\_\_\_\_, 20\_\_.

\_\_\_\_\_  
(Notary Public) My Commission Expires \_\_\_\_\_

**Certification Regarding  
Debarment, Suspension, and Other Responsibility Matters  
Primary Covered Transactions**

**EXHIBIT "B"**

This certification is required by the regulations implementing Executive Order 12549, Debarment and Suspension, 13 CFR Part 145 Subpart C 145.200 - 145.325. The regulations were published as Part VII of the May 26, 1988 *Federal Register* (pages 19160-19211). Copies of the regulations are available from local offices of the U.S. Small Business Administration.

**(BEFORE COMPLETING CERTIFICATION, READ INSTRUCTIONS ON REVERSE)**

- (1) The prospective primary participant certifies to the best of its knowledge and belief that it and its principals:
  - (a) You are not presently debarred, suspended, proposed for disbarment, declared ineligible, or voluntarily excluded from covered transactions by any Federal department or agency;
  - (b) You have not within a three-year period preceding this application been convicted of or had a civil judgment rendered against them for commission of fraud or a criminal offense in connection with obtaining, attempting to obtain, or performing a public (Federal, State, or local) transaction or contract under a public transaction; violation of Federal or State antitrust statutes or commission of embezzlement, theft, forgery, bribery, falsification or destruction of records, making false statements, or receiving stolen property;
  - (c) You are not presently indicted for or otherwise criminally or civilly charged by a governmental entity (Federal, State, or local) with commission of any of the offenses enumerated in paragraph (1)(b) of this certification; and
  - (d) You have not within a three-year period preceding this application had one or more public transactions (Federal, State, or local) terminated for cause or default.
- (2) Where the prospective primary participant is unable to certify to any of the statements in this certification, such prospective primary participant shall attach an explanation to this proposal.

Business Name \_\_\_\_\_

Date \_\_\_\_\_

By \_\_\_\_\_  
Name and Title of Authorized Representative

\_\_\_\_\_  
Signature of Authorized Representative

### INSTRUCTIONS FOR CERTIFICATION

1. By signing and submitting this proposal, the prospective primary participant is providing the certification set out below.
2. The inability of a person to provide the certification required below will not necessarily result in denial of participation in this covered transaction. The prospective participant shall submit an explanation of why it cannot provide the certification set out below. The certification or explanation will be considered in connection with the department or agency's determination whether to enter into this transaction. However, failure of the prospective primary participant to furnish a certification or an explanation shall disqualify such person from participation in this transaction.
3. The certification in this clause is a material representation of fact upon which reliance was placed when the department or agency determined to enter into this transaction. If it is later determined that the prospective primary participant knowingly rendered an erroneous certification, in addition to other remedies available to the Federal Government, the department or agency may terminate this transaction for cause or default.
4. The prospective primary participant shall provide immediate written notice to the department or agency to which this proposal is submitted if at any time the prospective primary participant learns that its certification was erroneous when submitted or has become erroneous by reason of changed circumstances.
5. The terms "covered transaction," "debarred," "suspended," "ineligible," "lower tier covered transaction," "participant," "person," "primary covered transaction," "principal," "proposal," and "voluntarily excluded," as used in this clause, have the meanings set out in the Definitions and Coverage sections of the rules implementing Executive Order 12549. You may contact the department or agency to which this proposal is submitted for assistance in obtaining a copy of those regulations (13 CFR Part 145).
6. The prospective primary participant agrees by submitting this proposal that, should the proposed covered transaction be entered into, it shall not knowingly enter into any lower tier covered transaction with a person who is debarred, suspended, declared ineligible, or voluntarily excluded from participation in this covered transaction, unless authorized by the department or agency entering into this transaction.
7. The prospective primary participant further agrees by submitting this proposal that it will include the clause titled "Certification Regarding Debarment, Suspension, Ineligibility and Voluntary Exclusion--Lower Tier Covered Transactions," provided by the department or agency entering into this covered transaction, without modification, in all lower tier covered transactions and in all solicitations for lower tier covered transactions.
8. A participant in a covered transaction may rely upon a certification of a prospective participant in a lower tier covered transaction that it is not debarred, suspended, ineligible, or voluntarily excluded from the covered transaction, unless it knows that the certification is erroneous. A participant may decide the method and frequency by which it determines the ineligibility of its principals. Each participant may, but is not required to, check the Nonprocurement List.
9. Nothing contained in the foregoing shall be construed to require establishment of a system of records in order to render in good faith the certification required by this clause. The knowledge and information of a participant is not required to exceed that which is normally possessed by a prudent person in the ordinary course of business dealings.
10. Except for transactions authorized under paragraph 6 of these instructions, if a participant in a covered transaction knowingly enters into a lower tier covered transaction with a person who is suspended, debarred, ineligible, or voluntarily excluded from participation in this transaction, in addition to other remedies available to the Federal Government, the department or agency may terminate this transaction for cause or default.

**Pt. 145**

(1) Making an administrative offset against other requests for reimbursements.

(2) Withholding advance payments otherwise due to the grantee, or

(3) Other action permitted by law.

(b) Except where otherwise provided by statutes or regulations, the Federal agency will charge interest on an overdue debt in accordance with the Federal Claims Collection Standards (4 CFR Ch. II). The date from which interest is computed is not extended by litigation or the filing of any form of appeal.

**Subpart E—Entitlements  
[Reserved]**

**PART 145—GOVERNMENTWIDE DEBARMENT AND SUSPENSION (NONPROCUREMENT) AND GOVERNMENTWIDE REQUIREMENTS FOR DRUG-FREE WORKPLACE (GRANTS)**

**Subpart A—General**

- Sec.
- 145.100 Purpose.
- 145.105 Definitions.
- 145.110 Coverage.
- 145.115 Policy.

**Subpart B—Effect of Action**

- 145.200 Debarment or suspension.
- 145.205 Ineligible persons.
- 145.210 Voluntary exclusion.
- 145.215 Exception provision.
- 145.220 Continuation of covered transactions.
- 145.225 Failure to adhere to restrictions.

**Subpart C—Debarment**

- 145.300 General.
- 145.305 Causes for debarment.
- 145.310 Procedures.
- 145.311 Investigation and referral.
- 145.312 Notice of proposed debarment.
- 145.313 Opportunity to contest proposed debarment.
- 145.314 Debarring official's decision.
- 145.315 Settlement and voluntary exclusion.
- 145.320 Period of debarment.
- 145.325 Scope of debarment.

**Subpart D—Suspension**

- 145.400 General.
- 145.405 Causes for suspension.
- 145.410 Procedures.

**13 CFR Ch. I (1–1–01 Edition)**

- 145.411 Notice of suspension.
- 145.412 Opportunity to contest suspension.
- 145.413 Suspending official's decision.
- 145.416 Period of suspension.
- 145.420 Scope of suspension.

**Subpart E—Responsibilities of GSA, Agency and Participants**

- 145.500 GSA responsibilities.
- 145.505 SBA responsibilities.
- 145.510 Participants' responsibilities.

**Subpart F—Drug-Free Workplace Requirements (Grants)**

- 145.600 Purpose.
- 145.605 Definitions.
- 145.610 Coverage.
- 145.615 Grounds for suspension of payments, suspension or termination of grants, or suspension or debarment.
- 145.620 Effect of violation.
- 145.625 Exception provision.
- 145.630 Certification requirements and procedures.
- 145.635 Reporting of and employee sanctions for convictions of criminal drug offenses.

**APPENDIX A TO PART 145—CERTIFICATION REGARDING DEBARMENT, SUSPENSION, AND OTHER RESPONSIBILITY MATTERS—PRIMARY COVERED TRANSACTIONS**

**APPENDIX B TO PART 145—CERTIFICATION REGARDING DEBARMENT, SUSPENSION, INELIGIBILITY AND VOLUNTARY EXCLUSION—LOWER TIER COVERED TRANSACTIONS**

**APPENDIX C TO PART 145—CERTIFICATION REGARDING DRUG-FREE WORKPLACE REQUIREMENTS**

**AUTHORITY:** E.O. 12549; Secs. 5151–5160 of the Drug-Free Workplace Act of 1988 (Pub. L. 100-690, Title V, Subtitle D; 41 U.S.C. 701 et seq.); 15 U.S.C. 684(b)(6).

**CROSS REFERENCE:** See also Office of Management and Budget notice published at 55 FR 21679, May 26, 1990, and 60 FR 33036, June 26, 1995.

**SOURCE:** 53 FR 19176, 19204, May 26, 1988, unless otherwise noted.

**EDITORIAL NOTE:** For additional information, see related documents published at 52 FR 20360, May 29, 1987, 53 FR 19160, May 26, 1988, and 53 FR 34474, Sept. 8, 1988.

**Subpart A—General**

**§145.100 Purpose.**

(a) Executive Order (E.O.) 12549 provides that, to the extent permitted by law, Executive departments and agencies shall participate in a government-wide system for nonprocurement debarment and suspension. A person who is

**ADDENDUM NO. 2**

PROJECT TITLE: Renovations to  
Jonesboro Recreation Center – Phase II  
Jonesboro, Arkansas

OWNER: City of Jonesboro  
300 S. Church St.  
Jonesboro, AR 72401

OWNER'S REPRESENTATIVE: Honorable Mayor Harold Copenhaver  
(870) 932-1052 Office

ARCHITECT: Brackett-Krennerich and Associates P.A.  
100 East Huntington Avenue, Suite D  
Post Office Box 1655  
Jonesboro, Arkansas 72403-1655  
(870) 932-0571 *office*

COMMISSION NUMBER: 2127

DATE OF ISSUE: March 16, 2022

BID DATE/LOCATION: **March 23, 2022 at 2:00 p.m.** C.D.S.T  
1<sup>st</sup> Floor Conference Room at the Municipal Building Center  
300 S. Church St.  
Jonesboro, AR 72401

---

---

Contractor shall take note of the following listed revisions and/or additions to the drawings and specifications for the above referenced project and adjust the contract sum accordingly. These revisions are hereby made a part of said documents and subsequent construction as if therein included.

---

---

***GENERAL***

1. Specifications: Section 00 0115 – List of Drawing Sheets
  - A. Clarification: Structural, Mechanical, Plumbing, Fire Protection, Electrical drawings bear an issue date of February 25, 2022. These along with Architectural drawings dated February 20, 2022, form the contract documents.

---

*CIVIL*

---

2. Drawings: Sheet C001 – Site Plan and Details

- A. Clarification: Fire line indicated on sheet F100 will require the cutting/trenching through existing asphalt parking lot to tie into main water line at Nettleton and to set new fire hydrant. Provide an allowance in base bid to include cutting, removing, and repair to existing asphalt parking lot. A trench 3'-0" wide will require removal/repair of 554 SF of asphalt. Asphalt repair section shall be 3" A.C.H.M. Surface course Type 2 & 6" Class 7 aggregate base course compacted to 95% modified proctor.

---

*ARCHITECTURAL*

---

3. Specifications: Section 07 2116 – Blanket Insulation; 2.02 Batt. Insulation Materials: Add the following:

7. Facing: Kraft faced, one side  
a. ASTM C 665; Federal Specification HH-1-521F, Type II.
8. Facing: Foil faced, one side  
a. ASTM E84; Max. flame spread index: 25; Max. smoke development index: 50  
b. Install foil faced insulation when exposed on exterior walls

4. Specifications: Section 07 2116 – Blanket Insulation; 3.03 Schedules:

- A. Interior Walls: (add the following)  
2. 6" inch thick, un-faced, R-Value, R-19.  
3. 1 1/2 inch thick, Kraft-faced, R-Value, R-6.

5. Specifications: Section 09 6250 – Resilient Sports Floor

- A. Clarification: Court striping is to be included in this scope of work. (3) colors will be used for striping.

6. Drawings: Sheet A100.1 – Partial demolition, floor plan, and reflected ceiling plan

- A. Add the following sheet: A100.1– Partial demolition, floor plan, and reflected ceiling plan.

- B. This area of the building is indicated on Sheet C001 (siteplan) as existing lobby and existing storage (at the southeast corner of the main building).

7. Drawings: Sheet A601 – Toilet Elevations

- A. Clarification: Provide “Schluter Jolly” trim at top and bottom termination of epoxy wainscot.

---

*MECHANICAL*

---

8. Drawings: Sheet M202 – FIRST FLOOR HVAC LOBBY PLAN - NEW

- A. Add radiant ceiling panel heaters to floor plan.
- B. Add Keyed Notes #1 and #2.
- C. Add “Radiant Ceiling Panel Heaters Schedule”.
- D. Revise Sequence of Operations.

---

*FIRE PROTECTION*

---

9. Drawings: Sheet F100 – SITE PLAN – FIRE PROTECTION

- A. Add fire hydrant to site plan.
- B. Relocate post indicator valve.
- C. Add Detail #2, “Fire Hydrant Detail”.

10. Drawings: Sheet F102 – FIRST FLOOR FIRE PROTECTION LOBBY PLAN - NEW

- D. Extend fire protection scope to include existing lobby, concession, office, and storage area.
- E. Add fire suppression hazard classification to existing lobby, concession, office, and storage.

---

*ELECTRICAL*

---

11. Specifications: Section 26 36 00 – DIESEL-ENGIN-DRIVEN GENERATOR SETS

- F. Section 2.02.E, Change EPA Tier 4 to EPA Tier 3.
- G. Section 2.09.A.2, Omit ‘walk-in’ requirement for generator enclosure.



12. Specifications: Section 27 15 13 – Communications Copper Horizontal Cabling

- H. Section 2.03.F, Cable jacket shall be RED for computer network and BLUE for voip telephone.
- I. General, RJ45 jacks shall be CommScope GigaSPEED XL MGS400 Series per Jonesboro IT standards.

13. Drawings: Sheet E104 – ELECTRICAL PLANS - NEW

- J. ELECTRICAL PLAN – FIRST FLOOR – NEW and ELECTRICAL PLAN – SECOND FLOOR - NEW, updated to reflect additional data and camera locations.
- K. ELECTRICAL PLAN – FIRST FLOOR – NEW, updated generator location to the north west corner of the building.

14. Drawings: Sheet E106 – ELECTRICAL PLAN – LOBBY – NEW

- L. ELECTRICAL PLAN – LOBBY – NEW, added power to new radiant heaters.

15. Drawings: Sheet E601 – ELECTRICAL SCHEDULES

- M. ELECTRICAL EQUIPMENT SCHEDULE, updated to add radian heater information.



### RADIANT CEILING PANEL HEATERS

DESIGNATION	REFERENCE PRODUCT	PANEL SIZE (INCH)	USING (WATTS)	VOLTS	WATER/PHASE	AMPS	REMARKS
HP-2	MANLEY CP-200	48"x48"	750	208V	120A	4.3	INSTALL WITH THE CEILING TIE. SUPPORT LIVE WITH EXISTING 1" DIA CEILING GRID
HP-3	MANLEY CP-200	48"x48"	750	208V	120A	4.3	INSTALL WITH THE CEILING TIE. SUPPORT LIVE WITH EXISTING 1" DIA CEILING GRID
						0.3	INSTALL WITH THE CEILING TIE. SUPPORT LIVE WITH EXISTING 1" DIA CEILING GRID

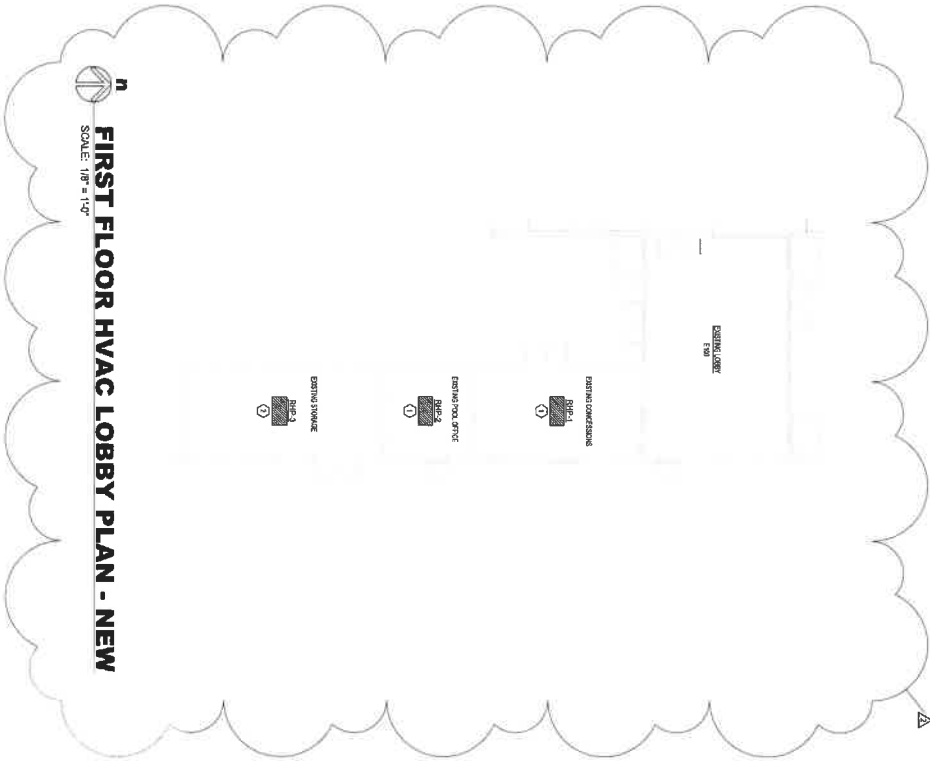

- ### KEYED NOTES:
- INSTALL RADIANT CEILING PANEL HEATERS IN PLACE OF EXISTING CEILING TIE. SUPPORT LIVE WITH EXISTING 1" DIA CEILING GRID
  - EXISTING TOWNHOME TIE SHOULD BE REMOVED AND TIE CONTROLS TO MAIN HALLWAY. TIE CONTROLS TO EXISTING TIE AND CONTROLS BY
  - INSTALL TIE CONTROLS TO MAIN HALLWAY. TIE CONTROLS TO EXISTING TIE AND CONTROLS BY



Commission Number  
 2127  
**M202**  
 Date February 23, 2022

Revision Schedule			
No.	Description	Date	By
1	As Issued	01/13/22	BCA



**Renovations to  
 Jonesboro Recreational Center  
 Jonesboro Arkansas  
 Phase II**

ADDENDUM NO. 2  
 March 16, 2022  
 Page 6 of 11

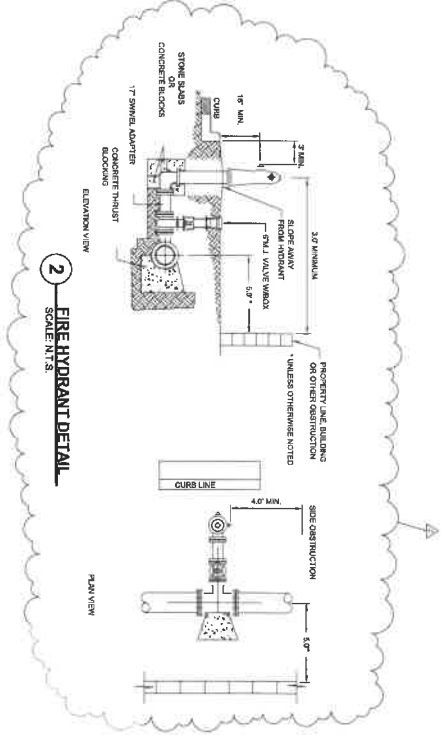
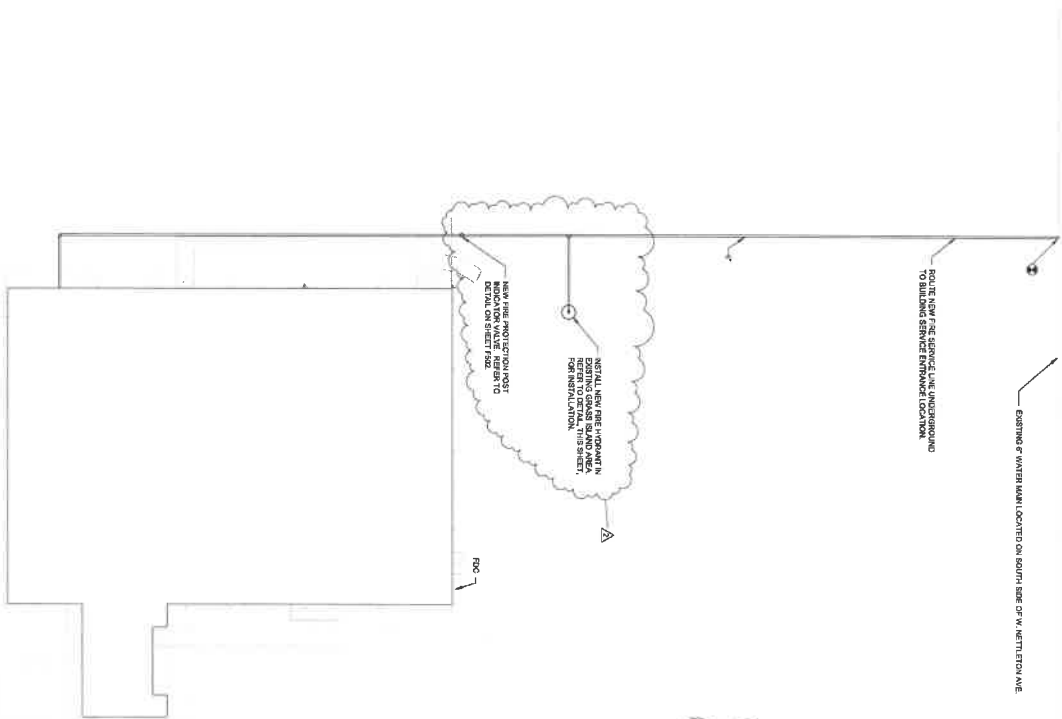

**SITE PLAN - FIRE PROTECTION**  
 SCALE: 1/8" = 1'-0"



Commission Number  
**F 100**  
 2127  
 Date: February 28, 2022





Revision Schedule			
NO.	DATE	BY	REVISION

**BRACKETT KRENNERICH**  
 architects

Renovations to  
**Jonesboro Recreational Center**  
 Jonesboro Arkansas  
 Phase II

GENERAL NOTES:  
1. HAZARDOUS MATERIALS SHALL BE IDENTIFIED IN ACCORDANCE WITH NFPA 11 (2021) AND THE CITY OF JONESBORO.  
2. SPHERICAL PIPING AND ELECTRICAL PANELS SHALL BE PROVIDED. SPHERICAL PANELS WITH GUARDS SHOULD BE USED.  
3. ALL SPHERICAL PIPING OR ELECTRICAL PANELS SHALL BE IDENTIFIED WITH THEIR OWNERS.

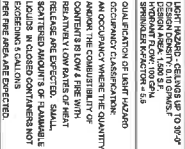
**FIRE SUPPRESSION HAZARD CLASSIFICATIONS**

	<p><b>HAZARDOUS MATERIALS - CLASSIFIED UP TO 300°</b></p> <p>HAZARDOUS MATERIALS SHALL BE IDENTIFIED IN ACCORDANCE WITH NFPA 11 (2021) AND THE CITY OF JONESBORO.</p> <p>SPHERICAL PIPING = 4.5</p>
	<p><b>HAZARDOUS MATERIALS - CLASSIFIED UP TO 300°</b></p> <p>HAZARDOUS MATERIALS SHALL BE IDENTIFIED IN ACCORDANCE WITH NFPA 11 (2021) AND THE CITY OF JONESBORO.</p> <p>SPHERICAL PIPING = 4.5</p>
	<p><b>QUALIFICATION OF LIGHT HAZARD</b></p> <p>AN OCCUPANT WHERE THE QUANTITY OF COMBUSTIBLE CONTENTS IS LOW &amp; FIRE WITH RELEASE ARE EXPECTED. SMALL SCATTERED AMOUNTS OF FLAMMABLE LIQUIDS IN CLOSED CONTAINERS NOT BEING OPENED ARE EXPECTED.</p>
	<p><b>QUALIFICATION OF MODERATE HAZARD</b></p> <p>AN OCCUPANT WHERE THE QUANTITY OF COMBUSTIBLE CONTENTS IS MODERATE TO NOT EXCEED 1000 FT<sup>2</sup> AND RISKS WITH RELEASE ARE EXPECTED. MODERATE SCATTERED AMOUNTS OF FLAMMABLE LIQUIDS IN CLOSED CONTAINERS NOT BEING OPENED ARE EXPECTED.</p> <p>THE HAZARDOUS MATERIALS SHOULD BE IDENTIFIED IN ACCORDANCE WITH NFPA 11 (2021) AND THE CITY OF JONESBORO.</p>

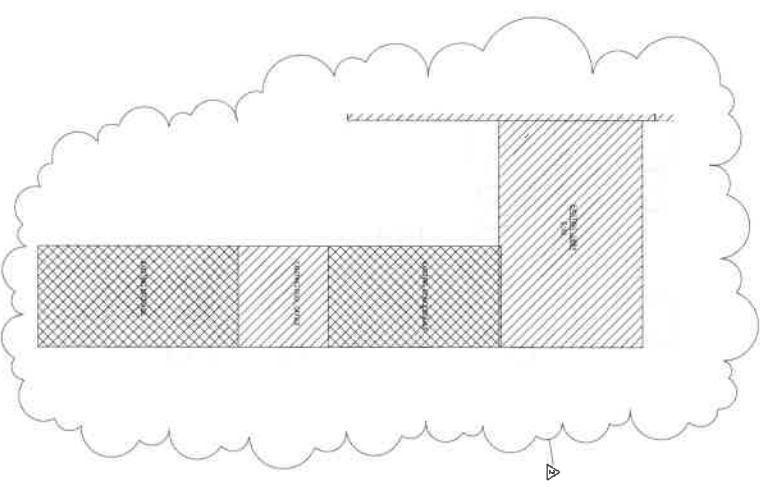

**FIRST FLOOR FIRE PROTECTION LOBBY PLAN - NEW**  
SCALE: 1/8" = 1'-0"

**Renovations to  
Jonesboro Recreational Center  
Jonesboro Arkansas  
Phase II**

**BRACKETT  
KRENNERICH**  
architects



Rev.	Description	Date	By
1	Submittal #1	03/16/22	lbesafik

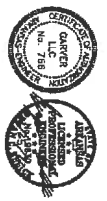

Commission Number  
**F102**  
2127  
Dated: February 25, 2022

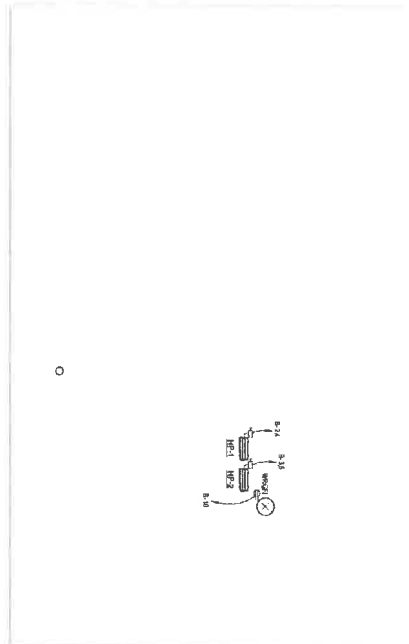

**ELECTRICAL PLAN - ROOF - NEW**  
SCALE: 1/8" = 1'-0"

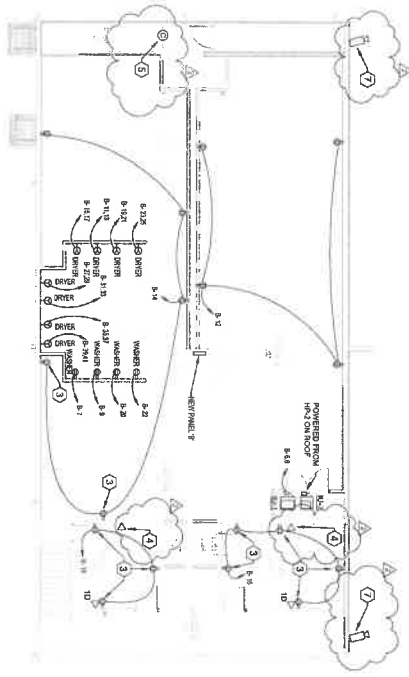

**ELECTRICAL PLAN - SECOND FLOOR - NEW**  
SCALE: 1/8" = 1'-0"

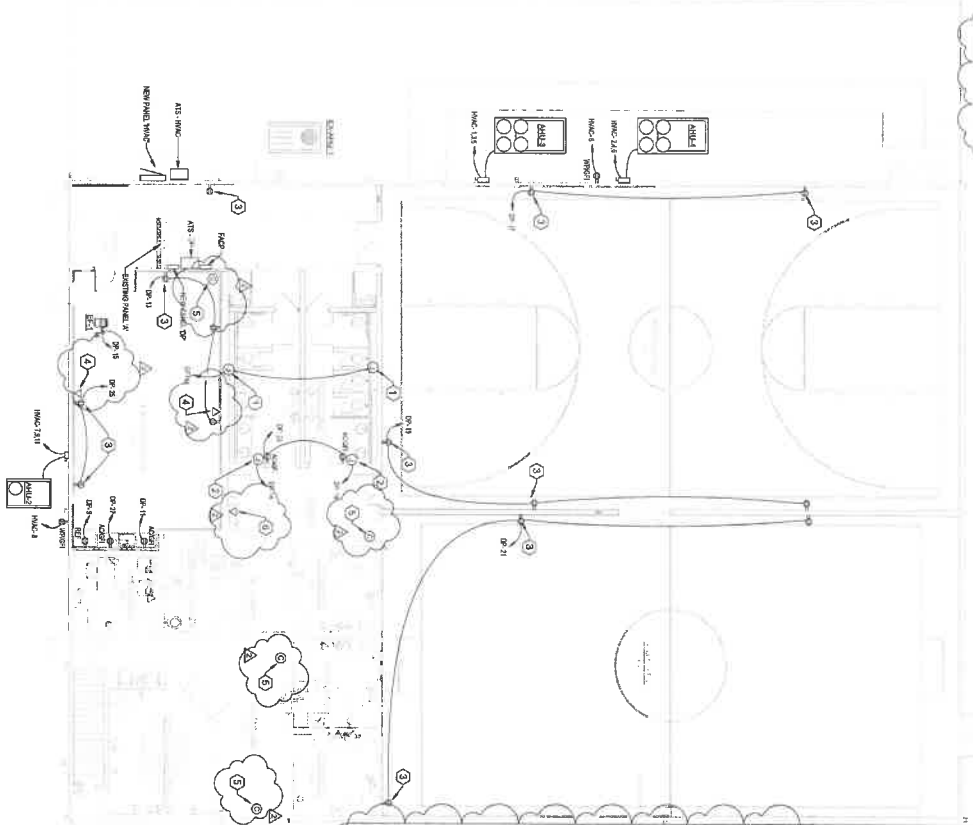
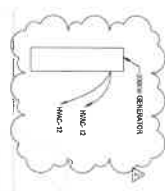

**ELECTRICAL PLAN - FIRST FLOOR - NEW**  
SCALE: 1/8" = 1'-0"

**ELECTRICAL KEYED NOTES**

- 1 PROVIDE POWER TO JUNCTION BOX ABOVE CEILING TO POWER FLUSH VALVES AND FALGOTS IN INSTALLATION OF JUNCTION BOX MOUNTED TRANSFORMER. PROVIDE FINAL CONNECTION FROM PROVIDE TRANSFORMER TO DEVICES PER INSTALLATION INSTRUCTIONS.
- 2 PREPARE JUNCTION RE-ENTRY POINT FOR OVERSIZED HAND DRIVER. COORDINATE THE EXACT LOCATION OF HAND DRIVER WITH ELECTRICAL CONTRACTOR TO INSTALLATION.
- 3 REUSE EXISTING RECEPTACLE LOCATION. PROVIDE NEW BACKBOX AND CONDUIT AT THIS LOCATION. PROVIDE NEW CONDUIT, ENTRY, AND COUPLERS.
- 4 NEW DATA LOCATION. AT EACH DATA POINT, PROVIDE ONE (1) NEW DATA CABLE AND ONE BLUE CATV DATA CABLES BACK TO EXISTING DATA RACK. TERMINATE DATA CABLES AT THE DEVICE. THE CITY WILL TERMINATE CABLES AT THE RACK.
- 5 CEILING MOUNTED CAMERA. PROVIDE ONE (1) NEW DATA CABLE BACK TO EXISTING DATA RACK. TERMINATE AND PROVIDE SLACK AT THE CITY. THE CITY WILL TERMINATE CABLES AT THE RACK.
- 6 CEILING MOUNTED WIRE ACCESS POINT LOCATION. PROVIDE ONE (1) NEW DATA CABLE AND ONE BLUE CATV DATA CABLES BACK TO EXISTING DATA RACK. TERMINATE AND PROVIDE SLACK AT THE CITY. THE CITY WILL TERMINATE CABLES AT THE RACK.
- 7 WALL MOUNTED CAMERA AND WIRE ACCESS POINT LOCATION. PROVIDE JUNCTION BOX WITH CONDUIT HIGH ON THE WALL. COORDINATE THE EXACT LOCATION OF JUNCTION BOX WITH ELECTRICAL CONTRACTOR PRIOR TO INSTALLATION. TERMINATE CABLES AT THE JUNCTION BOX. THE CITY WILL TERMINATE CABLES AT THE RACK.

Revised Schedule

Date	Revised Description	Revised By



Renovations to  
**Jonesboro Recreational Center**  
Jonesboro Arkansas  
Phase II

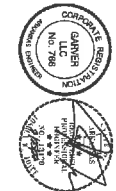

Commission Number  
2127  
**E104**  
Date: February 28, 2012

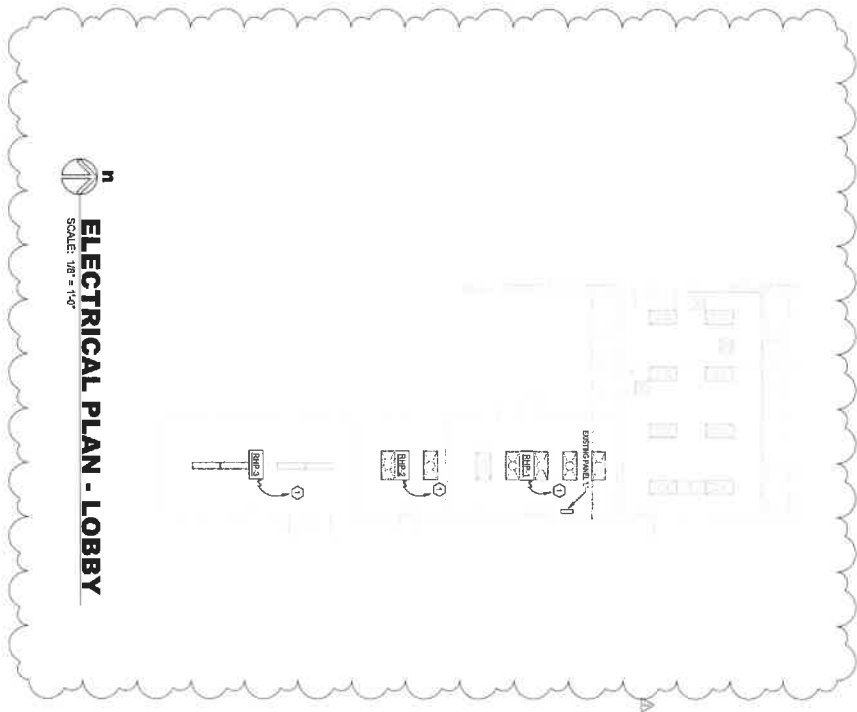

**ELECTRICAL PLAN - LOBBY**  
 SCALE: 1/8" = 1'-0"

**ELECTRICAL KEYED NOTES**  
 ① PROVIDE A NEW 20AMP CIRCUIT BREAKER IN EXISTING PANEL 'L' PANEL. PROVIDE NEW RADIANT HEATER.



Revision Schedule	
Rev.	By

**BRACKETT  
 KRENNERICH**  
 architects

**Renovations to  
 Jonesboro Recreational Center  
 Jonesboro Arkansas  
 Phase II**

Commission Number  
 2127  
**E106**  
 Date February 28 2022

ADDENDUM NO. 2  
 March 16, 2022  
 Page 10 of 11





**SECTION 00 1113**

**ADVERTISEMENT FOR BIDS**

Qualified Contractors are invited to bid on a contract for "Renovations to Jonesboro Recreation Center – Phase II". The bids shall be on a lump sum basis.

The City of Jonesboro, hereinafter termed owner, will receive bids until **2:00 p.m., Wednesday, March 23, 2022**. Bids may be mailed or delivered in care of Purchasing Agent, Steve Kent, Jonesboro City Hall, 300 South Church Street, Jonesboro, Arkansas 72401. Bids received after this time will not be accepted.

Bids will be publicly opened and read aloud at the stated time on the 1st Floor Conference Room at the Municipal Building Center, 300 South Church Street, Jonesboro, Arkansas.

Project scope consists of an approximately 15,600 SF interior renovation to the existing Jonesboro Recreational Center. Work includes restroom, multipurpose, and office renovations, two renovated basketball and soccer courts with synthetic sports flooring and synthetic turf. Mechanical systems include package air handling units and updated plumbing and fixtures. Electrical systems are being modified, as well as, new fire suppression system for facility. Exterior work is limited to egress sidewalks, drainage modifications and new exterior wall openings.

Plans, specifications, bid forms, and other contract documents may be examined at the office of the architect. While contract documents can be examined at the following plan rooms, bidders should use caution in doing so:

**Jonesboro Blueprint**  
**222 Madison Street**  
**Jonesboro, AR 72401**  
**(870) 932-4349**

**Southern Reprographics**  
**901 W. 7<sup>th</sup> Street**  
**Little Rock, AR 72201**  
**(501) 372-4011**

Obtaining contract documents through any source other than the Design Professional or their representative(s) is not advisable due to the risks of receiving incomplete or inaccurate information. Contract documents obtained through the Design Professional or their representative(s) are considered the official version and take precedence should any discrepancies occur. The official version of the complete set of the contract documents should be examined and are obtainable from Brackett-Krennerich and Associates, P.A., 100 E. Huntington, Suite D, Jonesboro, Arkansas. General contractors may obtain two (2) complete sets of bidding documents from Brackett-Krennerich and Associates upon deposit of **\$200.00** which is refundable, less postage/shipping costs, if applicable, to bona fide bidders upon return of documents in good condition within 3 days after bid date.

Additional sets of documents may be obtained for use by subcontractors and material suppliers upon receipt of **\$100.00** per set which is refundable less cost of reproduction (**50% refundable**), and less postage/shipping costs if applicable, upon return of documents in good condition within 3 days after the bid date. No partial sets will be issued.

Bid Security in the amount of five percent (5%) of the bid must accompany each bid in accordance with the Instructions to Bidders.

Bidders shall conform to the requirements of the Arkansas licensing laws and regulations for contractors, and shall be licensed before his bid is submitted.

The City of Jonesboro encourages all small, minority, and women business enterprises submit bids for capital improvements. Encouragement is also made to all general contractors that in the event they subcontract portions of their work, consideration is given to the identified groups.

There will be a **Pre-Bid Conference** held at the site on **Thursday, March 10, 2022**. The conference will start at exactly **2:00 p.m.** Prime contractors who arrive late or fail to attend this meeting may forfeit their bidding privilege. The owner reserves the right to waive this requirement and/or schedule additional meetings.

The owner reserves the right to reject any and all bids, or to waive any formalities.

March 2, 2022  
Mayor Harold Copenhaver  
City of Jonesboro  
(Bid # 2022:04)

**SECTION 00 4100**

**BID FORM**

**THE PROJECT AND THE PARTIES**

**1.01 TO:**

A. Owner: City of Jonesboro

**1.02 FOR:**

A. Renovations to Jonesboro Recreation Center – Phase II, Jonesboro, Arkansas

**1.03 DATE:** 3-23-2022 (Bidder to enter date)

**1.04 SUBMITTED BY:** (Bidder to enter name and address)

A. Bidder's Full Name Wagner General Contractors, Inc.

1. Address 1711 Higginson Rd

2. City, State, Zip Searcy, AR 72143

**1.05 OFFER**

A. Having examined the Place of The Work and all matters referred to in the Instructions to Bidders and the Contract Documents prepared by Brackett-Krennerich and Associates, P. A. Architects for the above mentioned project, we, the undersigned, hereby offer to enter into a Contract to perform the Work for the Sum of:

B. \$ 1,630,500.00  
(dollar amount to be shown numerically)

C. We have included the required security Bid Bond as required by the Instructions to Bidders.

D. All applicable federal taxes are included and State of Arkansas taxes are included in the Bid Sum.

E. All cash allowances described in Section 01 2100 are included in the bid sum.

F. We understand that the owner reserves the right to reject any and all bids and waive any informalities in the bidding.

**1.06 ALLOWANCES**

A. Allowances described in Section 01 2100 are included in the bid price.

**1.07 ACCEPTANCE**

A. This offer shall be open to acceptance for thirty days from the bid closing date.

B. If this bid is accepted by the Owner within the time period stated above, we will:

1. Execute the Agreement within Ten (10) days of receipt of Notice of Award.
2. Furnish the required bonds within Ten (10) days of receipt of Notice of Award.
3. Commence work within Ten days after written Notice to Proceed of this bid.

C. If this bid is accepted within the time stated, and we fail to commence the Work or we fail to provide the required Bond(s), the security deposit shall be forfeited as damages to the Owner by reason of our failure, limited in amount to the lesser of the face value of the security deposit or the difference between this bid and the bid upon which a Contract is signed.

D. In the event our bid is not accepted within the time stated above, the required security deposit shall be returned to the undersigned, in accordance with the provisions of the Instructions to Bidders; unless a mutually satisfactory arrangement is made for its retention and validity for an extended period of time.

**1.08 CONTRACT TIME/LIQUIDATED DAMAGES**

- A. If this Bid is accepted, we will:
- B. Complete the work within 300 calendar days.
- C. Liquidated Damages: \$300.00 for liquidated damages will be assessed to the contractor for each calendar day that the contractor is in default after time stipulated in the contract documents.

**1.09 ADDENDA**

- A. The following Addenda have been received. The modifications to the Bid Documents noted below have been considered and all costs are included in the Bid Sum or price.

- 1. Addendum # 1 Dated 3-15-2022.
- 2. Addendum # 2 Dated 3-16-22.
- 3. Addendum # \_\_\_\_\_ Dated \_\_\_\_\_.
- 4. Addendum # \_\_\_\_\_ Dated \_\_\_\_\_.

**1.10 LISTING OF MECHANICAL, PLUMBING, ELECTRICAL AND ROOFING WORK**

- A. All mechanical, plumbing, electrical and roofing work shall be listed regardless of qualifications, licensures or work amount.
- B. Bidders should consult the project manual on how to fill out this form. Failure to fill out this form correctly shall cause the bid to be declared non-responsive and the bid will not receive consideration.

- 1. Indicate the Name(s), License Number(s) of each entity performing the listed work and the amount:

- C. MECHANICAL (Indicative of HVACR): Name- Cushmans Climate Control, Inc
  - 1. License No. 0197850326
  - 2. Is the amount of work \$20,000 or over: Yes  No
- D. PLUMBING: Name- Carson Construction LLC
  - 1. License No. 038530622
  - 2. Is the amount of work \$20,000 or over: Yes  No
- E. ELECTRICAL: Name- Martinez Electric
  - 1. License No. 0349500322
  - 2. Is the amount of work \$20,000 or over: Yes  No
- F. ROOFING & SHEETMETAL: Name- Collier Roofing
  - 1. License No. 0328280322
  - 2. Is the amount of work \$20,000 or over: Yes  No

**1.11 BID FORM SIGNATURE(S)**

- A. Company Name: Wagner General Contractors, Inc.
- B. Signature: 
- C. Printed Name: Shelton Allen Wagner, Jr
- D. Title: President
- E. Business Address: 1711 Higginson Rd, Searcy, AR 72143
- F. Contractor's License No. 0165491022
- G. Seal if bid is by a corporation.

**END OF BID FORM**

NON-COLLUSION AFFIDAVIT

EXHIBIT "A"

State of Arkansas

Bid # \_\_\_\_\_

County of White

I state that I am President of Wagner General Contractors, Inc.  
(Title) (Name of my firm)

and that I am authorized to make this affidavit on behalf of my firm, and its owners, directors, and officers. I am the person responsible in my firm for the price(s) and the amount of this bid.

I state that:

- 1) The price(s) and amount of this bid have been arrived at independently and without consultation, communication or agreement with any other contractor, bidder or potential bidder.
- 2) Neither the price(s) nor the amount of this bid, and neither the approximate price(s) nor approximate amount of this bid, have been disclosed to any other firm or person who is a bidder or potential bidder and they will not be discussed before bid opening.
- 3) No attempt has been made or will be made to induce any firm or person to refrain from bidding on this contract, or to submit a bid higher than this bid, or to submit any intentionally high or noncompetitive bid or other form of complementary bid.
- 4) The bid of my firm is made in good faith and not pursuant to any agreement or discussion with, or inducement from, any firm or person to submit a complementary or other noncompetitive bid.
- 5) Wagner General Contractors, Inc. its affiliates, subsidiaries, officers directors  
(Name of Firm)  
and employees are not currently under investigation by any governmental agency and have not in the last four years been convicted or found liable for any act prohibited by State or Federal law in any jurisdiction, involving conspiracy or collusion with respect to bidding on any public contract, except as follows:

I state that Wagner General Contractors, Inc. understands and acknowledges that the  
(Name of Firm)  
above representations are material and important and will be relied on by The City of Jonesboro  
(Name of Public Entity)  
in awarding the contract(s) for which this bid is submitted. I understand that my firm understands that any misstatement in this affidavit is and shall be treated as fraudulent concealment from The City of Jonesboro  
(Name of Public Entity)  
of the true facts relating to the submission for this contract.

Shelton Allen Wagner Jr, President  
(Name and Company Position)

SWORN TO AND SUBSCRIBED  
BEFORE ME THIS 23 DAY  
OF March, 2022.

Amanda D. Burnsed  
(Notary Public)

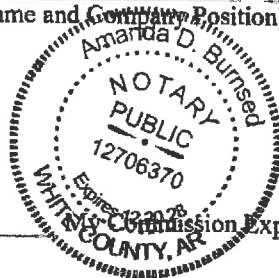

12.20.28

**Certification Regarding  
Debarment, Suspension, and Other Responsibility Matters  
Primary Covered Transactions**

**EXHIBIT "B"**

This certification is required by the regulations implementing Executive Order 12549, Debarment and Suspension, 13 CFR Part 145 Subpart C 145.200 - 145.325. The regulations were published as Part VII of the May 26, 1988 *Federal Register* (pages 19160-19211). Copies of the regulations are available from local offices of the U.S. Small Business Administration.

**(BEFORE COMPLETING CERTIFICATION, READ INSTRUCTIONS ON REVERSE)**

- (1) The prospective primary participant certifies to the best of its knowledge and belief that it and its principals:
- (a) You are not presently debarred, suspended, proposed for disbarment, declared ineligible, or voluntarily excluded from covered transactions by any Federal department or agency;
  - (b) You have not within a three-year period preceding this application been convicted of or had a civil judgment rendered against them for commission of fraud or a criminal offense in connection with obtaining, attempting to obtain, or performing a public (Federal, State, or local) transaction or contract under a public transaction; violation of Federal or State antitrust statutes or commission of embezzlement, theft, forgery, bribery, falsification or destruction of records, making false statements, or receiving stolen property;
  - (c) You are not presently indicted for or otherwise criminally or civilly charged by a governmental entity (Federal, State, or local) with commission of any of the offenses enumerated in paragraph (1)(b) of this certification; and
  - (d) You have not within a three-year period preceding this application had one or more public transactions (Federal, State, or local) terminated for cause or default.
- (2) Where the prospective primary participant is unable to certify to any of the statements in this certification, such prospective primary participant shall attach an explanation to this proposal.

Business Name Wagner General Contractors, Inc.

Date 3-23-2022

By Shelton Allen Wagner, Jr President  
Name and Title of Authorized Representative

  
Signature of Authorized Representative

THE AMERICAN INSTITUTE OF ARCHITECTS



AIA Document A310

**Bid Bond**

**KNOW ALL MEN BY THESE PRESENTS**, that **Wagner General Contractors, Inc.**

as Principal, hereinafter called the Principal, and **Travelers Casualty and Surety Company of America**

a corporation duly organized under the laws of the State of **Connecticut**

as Surety, hereinafter called the Surety, are held and firmly bound unto **City of Jonesboro City Hall, 300 South Church Street, Jonesboro, AR 72401.**

as Obligee, hereinafter called the Obligee, in the sum of **Five Percent of amount bid**  
Dollars(\$5% ),

for the payment of which sum well and truly to be made, the said Principal and the said Surety, bind ourselves, our heirs, executors, administrators, successors and assigns, jointly and severally, firmly by these presents.

WHEREAS, the Principal has submitted a bid for **Renovations to Jonesboro Recreation Center – Phase II**

NOW, THEREFORE, if the Obligee shall accept the bid of the Principal and the Principal shall enter into a Contract with the Obligee in accordance with the terms of such bid, and give such bond or bonds as may be specified in the bidding or Contract Documents with good and sufficient surety for the faithful performance of such Contract and for the prompt payment of labor and material furnished in the prosecution thereof, or in the event of the failure of the Principal to enter such Contract and give such bond or bonds, if the Principal shall pay to the Obligee the difference not to exceed the penalty hereof between the amount specified in said bid and such larger amount for which the Obligee may in good faith contract with another party to perform the Work covered by said bid, then this obligation shall be null and void, otherwise to remain in full force and effect.

Signed and sealed this **23rd** day of **March**, **2022.**

  
\_\_\_\_\_  
(Witness)

**Wagner General Contractors, Inc.**

  
\_\_\_\_\_  
(Principal) (Seal)  
(Title)

**Travelers Casualty and Surety Company of America**

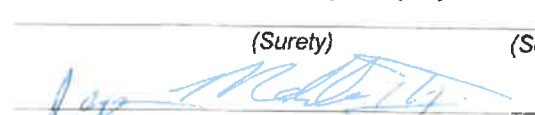
  
\_\_\_\_\_  
(Surety) (Seal)  
(Title)

  
\_\_\_\_\_  
**Nicole Lovett**  
(Witness)

**Joseph Madden III, Attorney-in-fact**



**Travelers Casualty and Surety Company of America  
Travelers Casualty and Surety Company  
St. Paul Fire and Marine Insurance Company**

**POWER OF ATTORNEY**

**KNOW ALL MEN BY THESE PRESENTS:** That Travelers Casualty and Surety Company of America, Travelers Casualty and Surety Company, and St. Paul Fire and Marine Insurance Company are corporations duly organized under the laws of the State of Connecticut (herein collectively called the "Companies"), and that the Companies do hereby make, constitute and appoint **Joseph Madden III** of **MEMPHIS**, Tennessee, their true and lawful Attorney(s)-in-Fact to sign, execute, seal and acknowledge any and all bonds, recognizances, conditional undertakings and other writings obligatory in the nature thereof on behalf of the Companies in their business of guaranteeing the fidelity of persons, guaranteeing the performance of contracts and executing or guaranteeing bonds and undertakings required or permitted in any actions or proceedings allowed by law.

**IN WITNESS WHEREOF**, the Companies have caused this instrument to be signed, and their corporate seals to be hereto affixed, this 21st day of April, 2021.



State of Connecticut

City of Hartford ss.

By:   
Robert L. Raney, Senior Vice President

On this the 21st day of April, 2021, before me personally appeared Robert L. Raney, who acknowledged himself to be the Senior Vice President of each of the Companies, and that he, as such, being authorized so to do, executed the foregoing instrument for the purposes therein contained by signing on behalf of said Companies by himself as a duly authorized officer

**IN WITNESS WHEREOF**, I hereunto set my hand and official seal.

My Commission expires the 30th day of June, 2026



  
Anna P. Nowik, Notary Public

This Power of Attorney is granted under and by the authority of the following resolutions adopted by the Boards of Directors of each of the Companies, which resolutions are now in full force and effect, reading as follows:

**RESOLVED**, that the Chairman, the President, any Vice Chairman, any Executive Vice President, any Senior Vice President, any Vice President, any Second Vice President, the Treasurer, any Assistant Treasurer, the Corporate Secretary or any Assistant Secretary may appoint Attorneys-in-Fact and Agents to act for and on behalf of the Company and may give such appointee such authority as his or her certificate of authority may prescribe to sign with the Company's name and seal with the Company's seal bonds, recognizances, contracts of indemnity, and other writings obligatory in the nature of a bond, recognizance, or conditional undertaking, and any of said officers or the Board of Directors at any time may remove any such appointee and revoke the power given him or her; and it is

**FURTHER RESOLVED**, that the Chairman, the President, any Vice Chairman, any Executive Vice President, any Senior Vice President or any Vice President may delegate all or any part of the foregoing authority to one or more officers or employees of this Company, provided that each such delegation is in writing and a copy thereof is filed in the office of the Secretary; and it is

**FURTHER RESOLVED**, that any bond, recognizance, contract of indemnity, or writing obligatory in the nature of a bond, recognizance, or conditional undertaking shall be valid and binding upon the Company when (a) signed by the President, any Vice Chairman, any Executive Vice President, any Senior Vice President or any Vice President, any Second Vice President, the Treasurer, any Assistant Treasurer, the Corporate Secretary or any Assistant Secretary and duly attested and sealed with the Company's seal by a Secretary or Assistant Secretary; or (b) duly executed (under seal, if required) by one or more Attorneys-in-Fact and Agents pursuant to the power prescribed in his or her certificate or their certificates of authority or by one or more Company officers pursuant to a written delegation of authority; and it is

**FURTHER RESOLVED**, that the signature of each of the following officers: President, any Executive Vice President, any Senior Vice President, any Vice President, any Assistant Vice President, any Secretary, any Assistant Secretary, and the seal of the Company may be affixed by facsimile to any Power of Attorney or to any certificate relating thereto appointing Resident Vice Presidents, Resident Assistant Secretaries or Attorneys-in-Fact for purposes only of executing and attesting bonds and undertakings and other writings obligatory in the nature thereof, and any such Power of Attorney or certificate bearing such facsimile signature or facsimile seal shall be valid and binding upon the Company and any such power so executed and certified by such facsimile signature and facsimile seal shall be valid and binding on the Company in the future with respect to any bond or understanding to which it is attached.

I, Kevin E. Hughes, the undersigned, Assistant Secretary of each of the Companies, do hereby certify that the above and foregoing is a true and correct copy of the Power of Attorney executed by said Companies, which remains in full force and effect.

Dated this 23rd day of March, 2022.



  
Kevin E. Hughes, Assistant Secretary

**To verify the authenticity of this Power of Attorney, please call us at 1-800-421-3880.  
Please refer to the above-named Attorney(s)-in-Fact and the details of the bond to which this Power of Attorney is attached.**





Legislation Details (With Text)

**File #:** RES-22:069    **Version:** 1    **Name:** APPLY FOR THE FY 2023 SELECTIVE TRAFFIC ENFORCEMENT PROGRAM (STEP) FROM THE ARKANSAS STATE POLICE

**Type:** Resolution    **Status:** To Be Introduced

**File created:** 4/5/2022    **In control:** Finance & Administration Council Committee

**On agenda:**    **Final action:**

**Title:** A RESOLUTION AUTHORIZING THE CITY OF JONESBORO GRANTS AND COMMUNITY DEVELOPMENT DEPARTMENT TO APPLY FOR THE FY 2023 SELECTIVE TRAFFIC ENFORCEMENT PROGRAM (STEP) FROM THE ARKANSAS STATE POLICE

**Sponsors:** Grants, Police Department

**Indexes:** Application, Grant

**Code sections:**

**Attachments:**

Date	Ver.	Action By	Action	Result
------	------	-----------	--------	--------

A RESOLUTION AUTHORIZING THE CITY OF JONESBORO GRANTS AND COMMUNITY DEVELOPMENT DEPARTMENT TO APPLY FOR THE FY 2023 SELECTIVE TRAFFIC ENFORCEMENT PROGRAM (STEP) FROM THE ARKANSAS STATE POLICE

WHEREAS, applications are now being accepted for the FY2023 Selective Traffic Enforcement Program; and

WHEREAS, the Selective Traffic Enforcement Program (STEP) funds are available at 100% federal participation with no local match required; and

WHEREAS, the total project cost is \$120,101.58, and the City of Jonesboro is requesting \$75,101.58 in Selective Traffic Enforcement Program (STEP) funding and will provide a local match of \$45,000.00 through in-kind services through officers' salaries and fringe benefits, vehicle maintenance, and child passenger clinics that are appropriated in the 2022 Budget and will be appropriated in the 2023 budget; and

NOW, THEREFORE BE IT RESOLVED BY THE CITY COUNCIL FOR THE CITY OF JONESBORO, ARKANSAS THAT:

SECTION 1: The Jonesboro City Council supports the submission of the 2023 application to the Selective Traffic Enforcement Program (STEP) for overtime pay of officers for seat belt enforcement, DWI/DUI enforcement, texting/cell phone use while driving enforcement, and speed enforcement. In addition, the City will purchase child safety seats; and

SECTION 2: The Mayor and the City Clerk are hereby authorized by the City Council for the City of Jonesboro, Arkansas to execute all necessary documents to effectuate the application; and

SECTION 3: The Grants and Community Development Department is hereby authorized by the City Council for the City of Jonesboro, Arkansas to submit all necessary documents for this federal grant.





## Legislation Details (With Text)

<b>File #:</b>	RES-22:070	<b>Version:</b>	1	<b>Name:</b>	CONTRACT WITH JONESBORO MONUMENT COMPANY FOR SPONSORSHIP OF ONE ATHLETIC FIELD AT THE SOUTHSIDE SOFTBALL SPORTS COMPLEX
<b>Type:</b>	Resolution	<b>Status:</b>		<b>Status:</b>	To Be Introduced
<b>File created:</b>	4/5/2022	<b>In control:</b>		<b>In control:</b>	Finance & Administration Council Committee
<b>On agenda:</b>		<b>Final action:</b>		<b>Final action:</b>	
<b>Title:</b>	A RESOLUTION OF THE CITY OF JONESBORO, ARKANSAS TO CONTRACT WITH JONESBORO MONUMENT COMPANY FOR SPONSORSHIP OF ONE ATHLETIC FIELD AT THE SOUTHSIDE SOFTBALL SPORTS COMPLEX				
<b>Sponsors:</b>	Parks & Recreation, Finance				
<b>Indexes:</b>	Agreement, Contract				
<b>Code sections:</b>					
<b>Attachments:</b>	<a href="#">Exhibit A - Jonesboro Monument Company Southside Complex 2022</a>				

Date	Ver.	Action By	Action	Result
------	------	-----------	--------	--------

A RESOLUTION OF THE CITY OF JONESBORO, ARKANSAS TO CONTRACT WITH JONESBORO MONUMENT COMPANY FOR SPONSORSHIP OF ONE ATHLETIC FIELD AT THE SOUTHSIDE SOFTBALL SPORTS COMPLEX

WHEREAS, the City of Jonesboro, Arkansas owns and maintains Southside Softball Sports Complex located at 5003 Stadium Blvd; and

WHEREAS, Jonesboro Monument Company is seeking sponsorship recognition on one softball field at the Southside Softball Sports Complex; and

WHEREAS, Jonesboro Monument Company is sponsoring the field for the sum of \$7,500 for a period of 5 years;

NOW, THEREFORE BE IT RESOLVED, BY THE CITY COUNCIL OF THE CITY OF JONESBORO, ARKANSAS

SECTION 1: That the City of Jonesboro, Arkansas shall contract with Jonesboro Monument Company for the sponsorship of a field at Southside Softball Sports Complex. A copy of said contract is attached as Exhibit A.

SECTION 2: The Mayor, Harold Copenhaver and City Clerk, April Leggett are hereby authorized by the City

Council for the City of Jonesboro to execute all documents necessary to effectuate the agreement.

# EXHIBIT A

## SPONSORSHIP AGREEMENT FOR ATHLETIC FIELD LOCATED AT SOUTHSIDE SOFTBALL COMPLEX

This Agreement is made by and between **Jonesboro Monument Company** (SPONSOR) and the CITY OF JONESBORO PARKS AND RECREATION DEPARTMENT ("CITY"), on this **21st** Day of **March, 2022** (the "Effective Date").

WHEREAS, the CITY is the owner of that certain public park amenities known as the "Southside Softball Complex", and hereafter referred to as the "Facilities"; and

WHEREAS, SPONSOR and the CITY desire to enter this agreement for the purpose of evidencing the agreement of the parties with regard to sponsorship of the Facilities by SPONSOR and the respective obligations of the parties regarding the sponsorship and maintenance of the Facilities;

NOW, THEREFORE in consideration of the promises and the reciprocated covenants and obligations contained herein, the parties agree as follows:

### I. Term

- (a) The term of this Agreement is for a period of five (5) years commencing on the Effective Date and ending at midnight on the **31<sup>st</sup> of June, 2027**.

### II. Sponsorship of Facilities

- 1) It is agreed between the parties hereto, in return for the covenants and conditions set forth herein that the SPONSOR'S name shall be put on a sign to be erected on a designated athletic field (Softball Field #9) at the FACILITY. The designated field, once SPONSOR enters into the Agreement, shall be known thereafter by the name to be designated by the SPONSOR and said sign and name shall remain for a period of **five years**.
- 2) It is agreed between the parties that the SPONSOR shall pay over a period of **5** years for the erected sign and sponsorship the total sum of **\$7,500**.
  - A sum of **\$500** shall be paid on **July 1, October 1, 2022** and **February 1, 2023**
  - A sum of **\$500** shall be paid on **July 1, October 1, 2023** and **February 1, 2024**
  - A sum of **\$500** shall be paid on **July 1, October 1, 2024** and **February 1, 2025**
  - A sum of **\$500** shall be paid on **July 1, October 1, 2025** and **February 1, 2026**
  - A sum of **\$500** shall be paid on **July 1, October 1, 2026** and **February 1, 2027**

- 3) It is agreed between the CITY and the SPONSOR that the SPONSOR shall have an option to renew this agreement for an additional five years.
- 4) It is agreed between the CITY and the SPONSOR that this sponsorship is non-assignable without prior written approval of the CITY. It is also agreed that the CITY reserves the right to remove SPONSOR'S sign and obtain a new sponsor for designated field in the event of failure of payment on the part of the SPONSOR.
- 5) It is agreed between the parties that the CITY will furnish a 2.5' x 14' sign to be erected for SPONSOR'S designated field. However, it shall be the responsibility of SPONSOR to bear any expense made to said sign should changes be requested during the term of this agreement.
- 6) It is agreed by CITY and the SPONSOR that the SPONSOR shall not be responsible for the maintenance or upkeep on sponsored field and SPONSOR shall not be responsible with regards to any liability actions which may be brought against the CITY resulting from accidents which might occur on sponsored field.

### **III. Assign ability and Exclusivity**

This Agreement is a privilege for the benefit of SPONSOR only and may not be assigned in whole or in part by SPONSOR to any other person or entity.

### **X. Miscellaneous Provisions.**

- 1) No modification of this Agreement shall be effective unless it is made in writing and is signed by the authorized representative's of the parties hereto.
- 2) This Agreement shall be construed under and in accordance with the laws of the State of Arkansas and venue for any litigation concerning this Agreement shall be in Craighead County, Jonesboro, AR.
- 3) Nothing in this Agreement shall be construed to make the CITY or its respective agents or representatives liable in situations it is otherwise immune from liability.
- 4) In case any one or more of the provisions contained in this Agreement shall for any reason be held invalid, illegal or unenforceable in any respect, such invalidity, illegality, or unenforceability shall not affect any other provision thereof and this Agreement shall be construed as if such invalid, illegal, or unenforceable provision had never been contained herein.

- 5) Each party represents to the other that the individual signing this Agreement below has been duly authorized to do so by its respective governing body and that this Agreement is binding and enforceable as to each party.

IN WITNESS WHEREOF, the parties have executed this Agreement on the day and year set forth below.

JONESBORO MONUMENT COMPANY

By:   
Name: Aaron B. Lovelady  
Title: Owner  
Date: 3-22-22

CITY OF JONESBORO

By: \_\_\_\_\_  
Name: Harold Copenhaver  
Title: Mayor  
Date: \_\_\_\_\_

ATTEST

\_\_\_\_\_

\_\_\_\_\_

Print Name



Legislation Details (With Text)

<b>File #:</b>	RES-22:071	<b>Version:</b>	1	<b>Name:</b>	WAIVE COMPETITIVE BIDDING AND AUTHORIZE THE MAYOR TO ENTER INTO AN AGREEMENT WITH ACTIVE NETWORK, LLC FOR THE PURCHASE OF POINT OF SALE EQUIPMENT FOR THE PARKS DEPARTMENT
<b>Type:</b>	Resolution	<b>Status:</b>			To Be Introduced
<b>File created:</b>	4/6/2022	<b>In control:</b>			Finance & Administration Council Committee
<b>On agenda:</b>		<b>Final action:</b>			
<b>Title:</b>	A RESOLUTION TO WAIVE COMPETITIVE BIDDING AND AUTHORIZE THE MAYOR TO ENTER INTO AN AGREEMENT WITH ACTIVE NETWORK, LLC FOR THE PURCHASE OF POINT OF SALE EQUIPMENT FOR THE PARKS DEPARTMENT				
<b>Sponsors:</b>	Parks & Recreation, Finance				
<b>Indexes:</b>	Agreement, Contract, Waive competitive bidding				
<b>Code sections:</b>					
<b>Attachments:</b>	<a href="#">ActiveNet POS Invoice</a>				

Date	Ver.	Action By	Action	Result
------	------	-----------	--------	--------

A RESOLUTION TO WAIVE COMPETITIVE BIDDING AND AUTHORIZE THE MAYOR TO ENTER INTO AN AGREEMENT WITH ACTIVE NETWORK, LLC FOR THE PURCHASE OF POINT OF SALE EQUIPMENT FOR THE PARKS DEPARTMENT

WHEREAS, the Parks Department for the City of Jonesboro needs Point of Sale Equipment that is capable of handling reservations, registrations, concessions, membership, and other items for the management of all of the sporting activities, and rental options in all of the city park properties.

WHEREAS, ActiveNet Point of Sale Equipment is capable of handling all of the needs of the Parks Department and is compatible with the approved web based software that works with the current financial software being used by the City of Jonesboro Finance Department and will therefore work seamlessly with that existing software.

WHEREAS, the cost of the ActiveNet Point OF Sale Equipment is \$42,652.11.

WHEREAS, the City Council in accord with the terms of A.C.A. Section 14-58-303 states that bidding in this matter is not practical and hereby waives the requirement of competitive bidding due to the fact that this Point Of Sale Equipment is compatible with the existing software being used by the City of Jonesboro Finance Department and will work seamlessly with said software without requiring modifications.

NOW, THEREFORE BE IT RESOLVED BY THE CITY COUNCIL OF THE CITY OF JONESBORO,

ARKANSAS:

SECTION 1: The 2022 budget is amended \$42,652.11 to purchase ActiveNet Point of Sale equipment.

SECTION 2: The City Council waives competitive bidding in accordance with the terms of A.C.A. Section 14-58-303.

SECTION 3: The Mayor and City Clerk are hereby authorized to execute such documents as are necessary to effectuate the agreement.





## Schedule

This is a Schedule pursuant to that certain Products and Services Agreement (Agreement) entered into between (Active) and CITY OF JONESBORO (Client) with an effective date as of 12/17/2021.

Company Address 5850 Granite Parkway, Suite 1200  
Plano, TX 75024  
US

Created Date 3/4/2022  
Quote Number 00124278  
Expiration Date 3/31/2022  
Currency USD

Prepared By Sharon Kramer  
Opportunity Owner Christopher Quinonez  
Owner Email [christopher.quinonez@activenetwork.com](mailto:christopher.quinonez@activenetwork.com)

Contact Name BRANDON SHRADER  
Phone 8709334604  
Email bshrader@jonesboro.org

Bill To Name CITY OF JONESBORO  
Bill To Contact BRANDON SHRADER  
Bill To Address 300 S Church Street  
Jonesboro, AR 72401 United States

Ship To Contact BRANDON SHRADER  
Ship To Address 300 S Church Street  
Jonesboro, AR 72401 United States

Product	Product Type	Quantity	Per Unit Price	Total Price*	Sales Price	Total Price	Total Discount Amount
ACTIVENet - APG S4000 Cash Drawer MultiPro Int - need printer (cable incl)	Hardware	18	USD 189.20	USD 3,405.60	USD 189.20	3,405.60	USD 0.00
ACTIVENet - Epson T-88V (USB) Thermal Receipt Printer	Hardware	18	USD 354.20	USD 6,375.60	USD 354.20	6,375.60	USD 0.00
ACTIVENet - Epson Thermal Receipt Paper	Hardware	9	USD 93.50	USD 841.50	USD 93.50	841.50	USD 0.00
ACTIVENet - Fargo Blank Cards 500 cards/box (without magstripe)	Hardware	6	USD 38.50	USD 231.00	USD 38.50	231.00	USD 0.00
ACTIVENet - Fargo DTC4000 Ribbon (DTC4000 YMCKO Cartridge w/Cleaning Roller)	Hardware	6	USD 71.50	USD 429.00	USD 71.50	429.00	USD 0.00
ACTIVENet - Fargo DTC4250 Card Printer - barcode printing only	Hardware	6	USD 2,899.00	USD 17,394.00	USD 2,899.00	17,394.00	USD 0.00
ACTIVENet - Metrologic MK7580 Genesis Imager, 110V Stand build-in, USB	Hardware	8	USD 453.00	USD 3,624.00	USD 453.00	3,624.00	USD 0.00
ACTIVENet - Microsoft Lifecam HD-3000	Hardware	26	USD 55.00	USD 1,430.00	USD 55.00	1,430.00	USD 0.00
ACTIVENet - PAX S300 Pin Pad	Hardware	18	USD 310.00	USD 5,580.00	USD 310.00	5,580.00	USD 0.00

Total Price

USD 39,310.70

Hardware Total

39,310.70

Active reserves the right, and may take additional measures to verify Client's account which may consist of reviewing publicly available data and/ confirmation of Client provided information. Such verification measures will be completed in advance of remittance.

All fees described herein are in consideration of the Software and Services that Active provides. Active and Client acknowledge that certain





## Legislation Details (With Text)

<b>File #:</b>	RES-22:072	<b>Version:</b>	1	<b>Name:</b>	ENTER INTO A CHANGE ORDER WITH RAMSONS INC.FOR THE JONESBORO SHOOTING SPORTS COMPLEX PHASE 1C (2020:07)
<b>Type:</b>	Resolution	<b>Status:</b>			To Be Introduced
<b>File created:</b>	4/6/2022	<b>In control:</b>			Finance & Administration Council Committee
<b>On agenda:</b>		<b>Final action:</b>			
<b>Title:</b>	A RESOLUTION OF THE CITY OF JONESBORO, ARKANSAS TO ENTER INTO A CHANGE ORDER WITH RAMSONS INC.FOR THE JONESBORO SHOOTING SPORTS COMPLEX PHASE 1C (2020:07)				
<b>Sponsors:</b>	Parks & Recreation, Police Department, Finance				
<b>Indexes:</b>	Change Order				
<b>Code sections:</b>					
<b>Attachments:</b>	<a href="#">Proposal Request</a>				

Date	Ver.	Action By	Action	Result
------	------	-----------	--------	--------

A RESOLUTION OF THE CITY OF JONESBORO, ARKANSAS TO ENTER INTO A CHANGE ORDER WITH RAMSONS INC.FOR THE JONESBORO SHOOTING SPORTS COMPLEX PHASE 1C (2020:07) WHEREAS, Resolution 20:025 authorized the City of Jonesboro to enter into a contract for the construction of the Jonesboro Shooting Sports Complex Phase IC with Ramsons Inc.;

WHEREAS, the City of Jonesboro desires to change the project with a Change Order as detailed in the attached Proposal Request increasing the contract amount by \$380,664.00; and,

WHEREAS, funding for the execution of the change order shall come from the Capital Improvement budget and compensation shall be paid in accordance with the contract documents.

NOW, THEREFORE BE IT RESOLVED, BY THE CITY COUNCIL OF THE CITY OF JONESBORO, ARKANSAS;

Section 1: That the City of Jonesboro hereby accepts a Change Order in the amount of \$380,664.00 from Ramsons Inc. for six (6) remaining trap fields for the Jonesboro Shooting Sports Complex Phase 1C construction.

Section 2. That funding for the execution of the change order shall come from the Capital Improvement budget and compensation shall be paid in accordance with the contract documents.

Section 3. The Mayor and the City Clerk are hereby authorized by the City Council for the City of Jonesboro to execute a Change Order and direct the Purchasing Agent to increase the Purchase Order amount.



RAMSONS INC.  
GENERAL CONTRACTORS  
3111 DAN AVENUE  
P.O. BOX 9185                      JONESBORO, AR 72403-9185

PHONE (870) 935-1210

FAX (870) 972-9255

April 6, 2022

**Brian Richardson**  
**Chief Administrative Officer**  
**City of Jonesboro**  
300 South Church Street  
Jonesboro, AR 72401

Re: Price for Completing Trap Fields at the Jonesboro Shooting Complex REVISED

Mr. Richardson:

Per your request, we are pleased to quote you the sum of \$380,664.00 to provide all labor and material required to complete the 6 remaining trap fields at the Jonesboro Shooting Complex. Our quote is based upon the attached PR #7.

If you have any questions or comments, please do not hesitate to contact me.

Sincerely,

Ramsons, Inc.

Scott McDaniel  
Vice President

Attachments

Cc: Kyle Cook, Craig Light

## Proposal Request (PR)

**Project: City of Jonesboro:**  
**Jonesboro Shooting Sports Complex**  
**Jonesboro, Arkansas**

**PR #** (7) Seven  
**Project #** 12015-IC  
**Date:** 03.31.22

---

**Owner:** City of Jonesboro

**Architect:** Brackett-Krennerich  
& Associates P.A.  
100 E. Huntington Ave. Suite D  
Jonesboro, AR 72401

**Contractor:** Ramsons Inc.  
General Contractors  
3111 Dan Avenue  
Jonesboro, AR 72403

Owner (email)  
 Contractor (email)  
 Consultant (email)  
 Field (email)  
 Other: BK Office (email)

**Attn:** Scott McDaniel

---

Please submit an itemized quotation for changes in the Contract Sum and/or Time incidental to proposed modifications to the Contract Documents described herein. **This is not a change order nor a direction to proceed with the work described herein.**

---

### Description:

Please provide the following modifications (Modifications indicated by delta "3")

- **Provide (6) trap fields and connecting walk as indicated on drawings on either side of trap/skeet fields.**
- **Provide (6) trap houses as indicated** (and including the following items at each location):
  - Sump pump
  - Electrical power as indicated (Refer to 5/E201 for requirements)
  - Lighting as indicated
  - Trap machine; Owner will set machine and calibrate.
  - Provide monumental sign at walk as detailed on C004.1.
  - Provide 2" conduit for trap controls back to central point for future controls and future clubhouse.



**Attachments:**

C003.6 – Trap Field Layout, C004 (Revised), C004.6 – Trap Field Layout,

**Issued by:**

**Kyle Cook, A.I.A. (Architect)**  
*(Printed name and title)*





CITY OF JONESBORO  
**JONESBORO SHOOTING  
 SPORTS COMPLEX**  
 PHASE 1C  
 Jonesboro, Arkansas



Revision Schedule	Issued	Rev. Date	By
1	Additional Traps	2022-03-31	JE

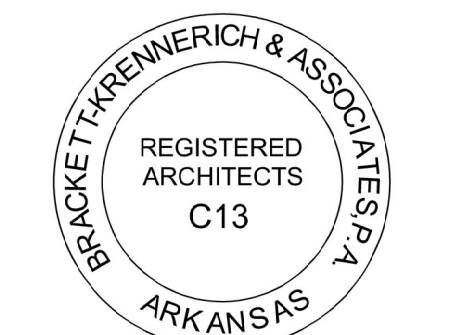

Commission Number  
 12015-1C  
**C003.6**  
 Date: March 31, 2022

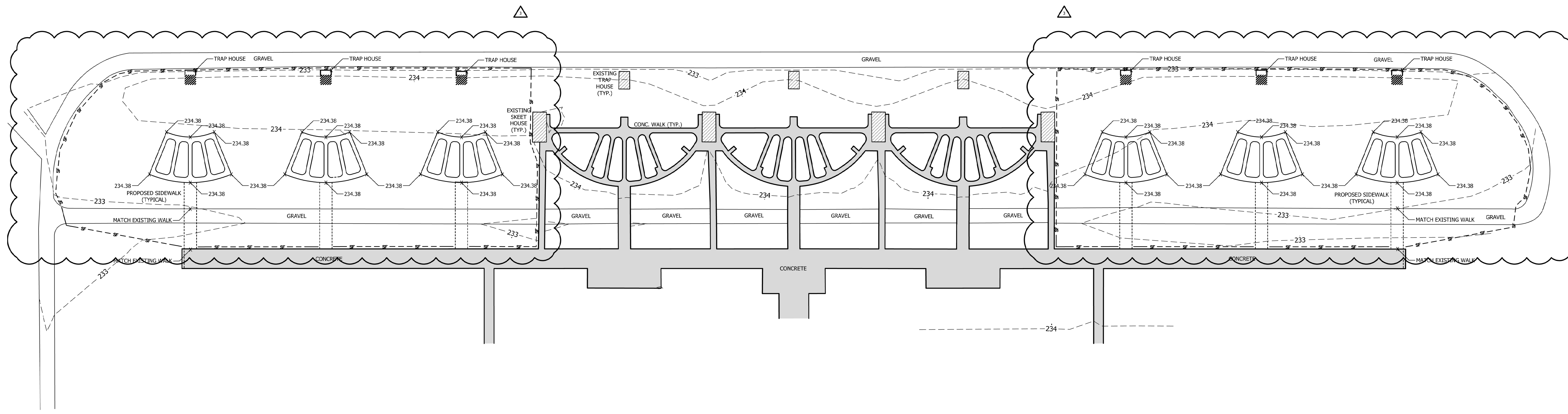
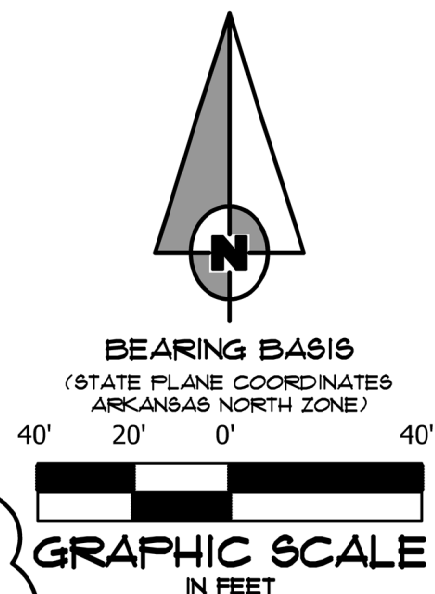

**SITE NOTES**

- ALL DIMENSIONS ARE TO THE FACE OF CURB, UNLESS OTHERWISE NOTED.
- ALL CURB RETURN RADII SHALL BE 5' UNLESS OTHERWISE NOTED.
- THROUGHOUT ALL EXCAVATION ACTIVITIES, POSITIVE DRAINAGE SHALL BE MAINTAINED WITHIN MINIMUM SLOPES OF 0.50% OR GREATER AND SURFACE DRAINAGE GENERALLY IN THE DIRECTION PROVIDED BY EXISTING TOPOGRAPHY.
- WORK SHALL PROGRESS IN SUCH A MANNER AS TO ALLOW THE EXISTING VEGETATION TO REMAIN AS LONG AS POSSIBLE CONSISTENT WITH THE SCOPE OF WORK.
- ALL ACCESSIBLE ROUTES SHALL HAVE A MAXIMUM CROSS SLOPE OF 2.0%. ALL ACCESSIBLE PARKING SPACES SHALL HAVE A MAXIMUM SLOPE OF 2.0% IN ALL DIRECTIONS.
- ALL SPOT ELEVATIONS ARE AS SHOWN.
- REMOVE AND DISPOSE OF ALL DEBRIS AND OTHER MATERIAL AS SHOWN IN ACCORDANCE WITH ALL LOCAL, STATE AND/OR FEDERAL REGULATIONS.
- ACCESS ALONG ROADWAY SHALL BE MAINTAINED AT ALL TIMES. CONSTRUCTION IN CITY, COUNTY OR STATE RIGHT OF WAY SHALL BE COORDINATED WITH THE RESPECTIVE AUTHORITY.
- TAKE ALL PRECAUTIONS NECESSARY TO AVOID PROPERTY DAMAGE TO ADJACENT PROPERTIES. THE CONTRACTOR SHALL GIVE AFFECTED PROPERTY OWNERS SUFFICIENT NOTICE PRIOR TO CONSTRUCTION OPERATIONS.

**LEGEND**

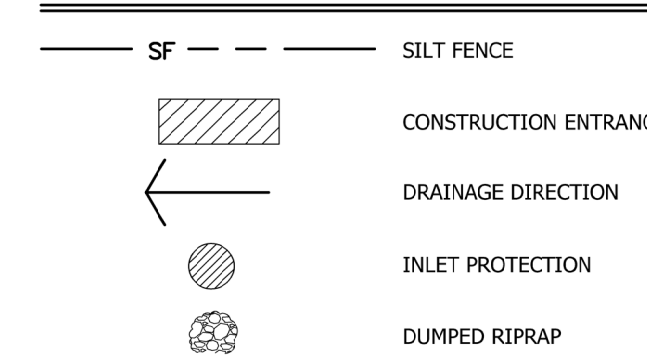

**EROSION CONTROL MEASURES**

- THE PURPOSE OF THIS PLAN IS TO ESTABLISH MINIMUM EROSION CONTROL MEASURES. THIS PLAN IS NOT INTENDED TO COVER ALL MEASURES, BUT TO SUPPLEMENT, EXPAND OR IMPLEMENT THE REQUIREMENTS OF THE STATE OF ARKANSAS NATIONAL POLLUTION DISCHARGE ELIMINATION SYSTEM GENERAL PERMIT (NPDES PERMIT).
- SILT FENCING SHALL BE PLACED ALONG THE LIMITS OF CONSTRUCTION AND AROUND EACH DRAINAGE STRUCTURE PRIOR TO CONSTRUCTION.
- GRAVEL CONSTRUCTION ENTRANCES SHALL BE CONSTRUCTED AT PROPOSED DRIVEWAY LOCATIONS TO PREVENT TRANSPORT OF SEDIMENT OFF SITE. WHEEL WASH FACILITIES MAY BE REQUIRED.
- THE CONTRACTOR SHALL BE RESPONSIBLE FOR INSTALLING ALL EROSION CONTROL MEASURES AND FACILITIES IN GOOD WORKING CONDITION THROUGHOUT THE ENTIRE CONSTRUCTION PERIOD. ANY FAILURES IN THE MEASURES MUST BE IMMEDIATELY REPAIRED. EROSION CONTROL MEASURES AND FACILITIES SHALL BE FREQUENTLY INSPECTED FOR COMPLIANCE. FAILURE TO INSTALL OR MAINTAIN THESE FACILITIES MAY RESULT IN DENIAL OF BUILDING INSPECTIONS UNTIL ALL PROBLEMS ARE CORRECTED. CONTRACTORS SHALL BE HELD ACCOUNTABLE FOR CONSTRUCTION VEHICLES TRACKING DIRT AND MUD ONTO PUBLIC STREETS. CONTRACTORS SHALL PUT INTO PLACE APPROPRIATE FACILITIES TO CLEAN VEHICLES BEFORE THEY ENTER STREETS. THE CONTRACTOR SHALL FREQUENTLY SWEEP THE ACCESS STREETS.
- THE OWNER SHALL BE RESPONSIBLE FOR SUBMITTING A NOTICE OF INTENT WITH THE ARKANSAS DEPARTMENT OF ENVIRONMENTAL QUALITY (ADEQ).
- DUST SHALL BE KEPT TO A MINIMUM. THE USE OF MOTOR OILS AND OTHER PETROLEUM BASED LIQUIDS FOR DUST SUPPRESSION ARE PROHIBITED.
- ALL WORK ON THIS SITE PERTAINING TO EXCAVATION AND DRAINAGE SHALL BE IN ACCORDANCE WITH THIS PLAN AND THE APPLICABLE PROVISIONS OF THE CITY OF JONESBORO STORM WATER MANAGEMENT REGULATIONS.
- ADDITIONAL CONTROLS MAY BE REQUIRED BY THE CITY OF JONESBORO AND ADEQ DURING CONSTRUCTION. GUIDELINES ESTABLISHED BY THE SOIL CONSERVATION SERVICE MAY BE REQUIRED FOR SEEDING OPERATIONS IF DETERMINED NECESSARY.

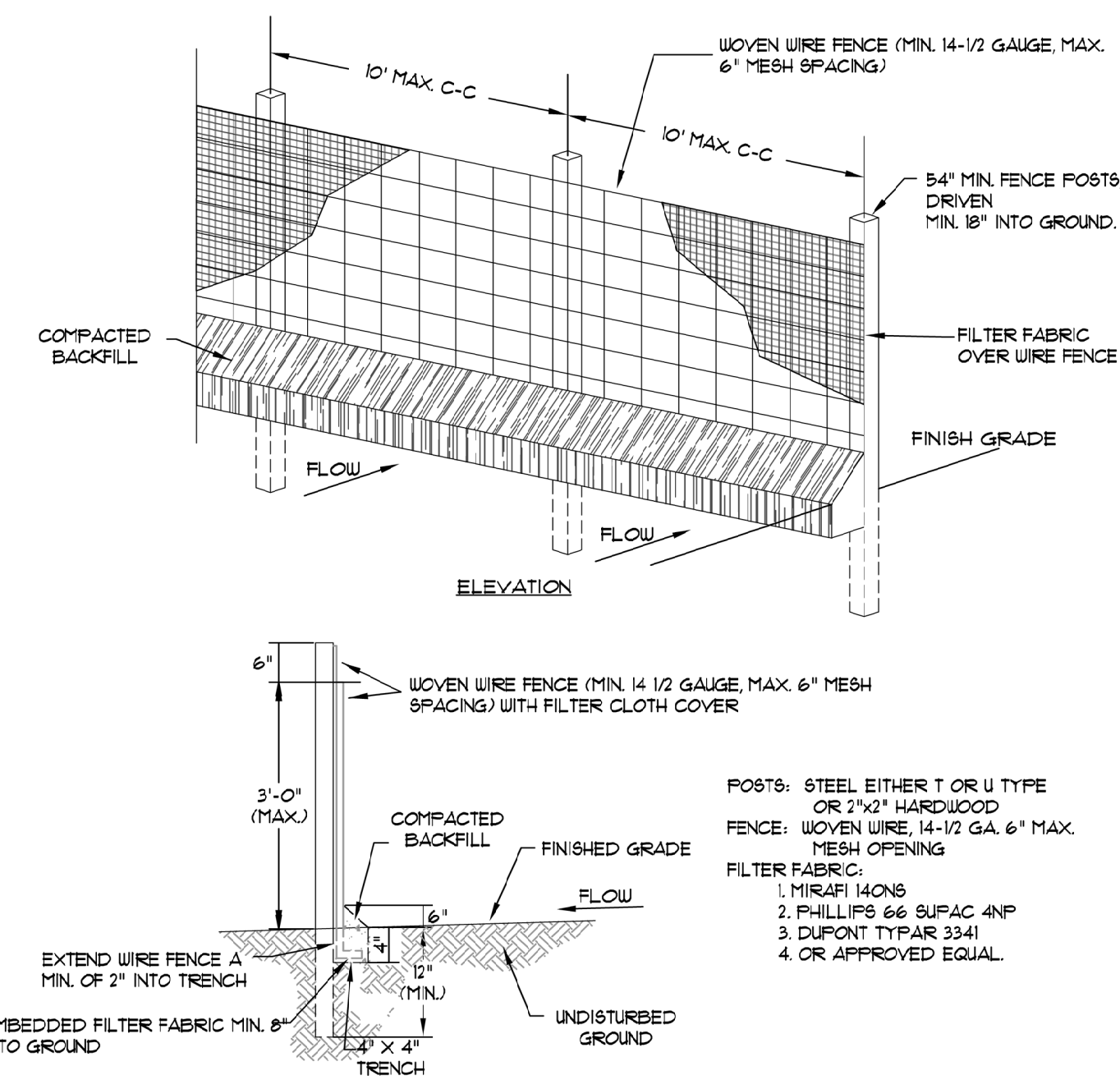

- WOVEN WIRE FENCE TO BE FASTENED SECURELY TO FENCE POSTS WITH WIRE TIES OR STAPLES.
- FILTER CLOTH TO BE FASTENED SECURELY TO WOVEN WIRE FENCE WITH TIES SPACED EVERY 24" AT TOP AND MID SECTION.
- WHEN TWO SECTIONS OF FILTER CLOTH ADJOIN EACH OTHER THEY SHALL BE OVERLAPPED BY SIX INCHES AND FOLDED.
- MAINTENANCE SHALL BE PERFORMED AS NOTED IN THE EROSION CONTROL PLAN. COLLECTED MATERIAL SHALL BE REMOVED WHEN "BULGES" DEVELOP IN THE SILT FENCE.

**SILT FENCE**  
 NOT TO SCALE

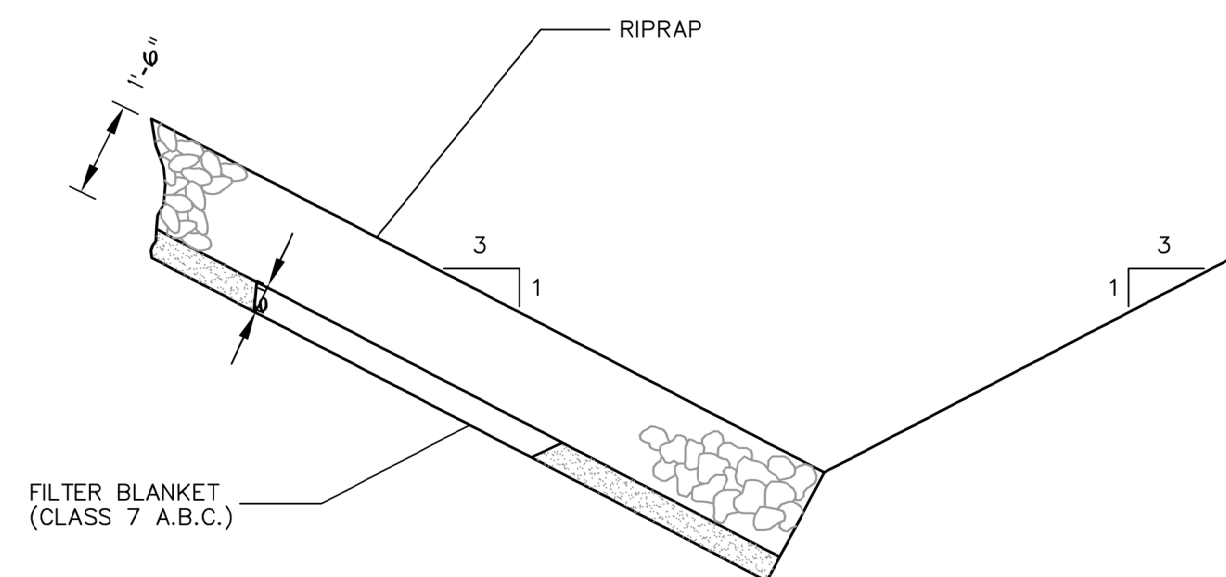
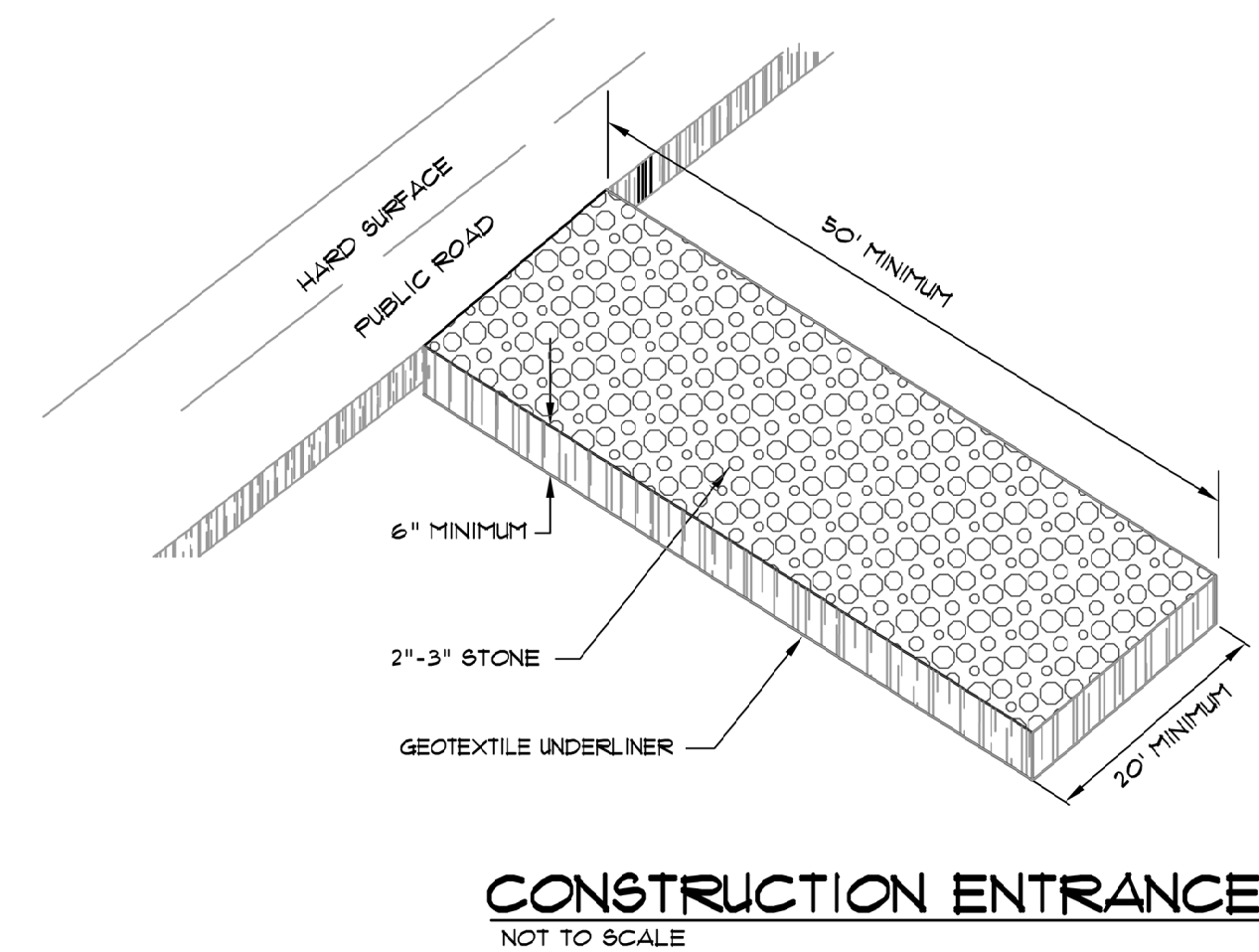

NOTE: IN LIEU OF AN AGGREGATE FILTER BLANKET, A SYNTHETIC FIBER GEOTEXTILE FABRIC MEETING THE REQUIREMENTS OF AASHTO M288 MAY BE USED. IN LIEU OF RIPRAP, AN EROSION CONTROL MAT MAY BE USED.

**SECTION - DUMPED RIPRAP**  
 TOE EXCAVATION IN SOIL



**grading and erosion control plan**

SCALE: 1" = 40'



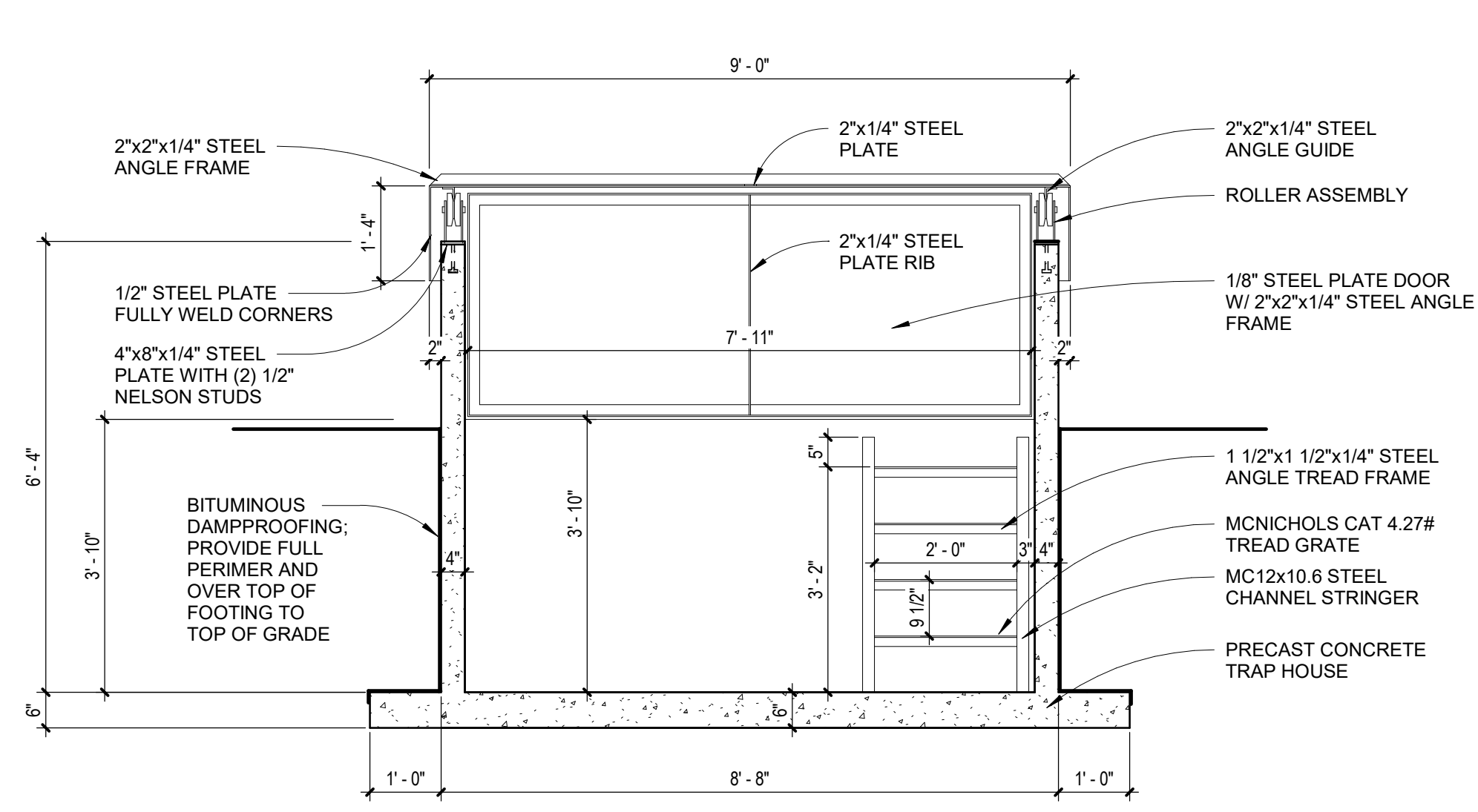

2 trap house section  
SCALE: 1/2" = 1'-0"

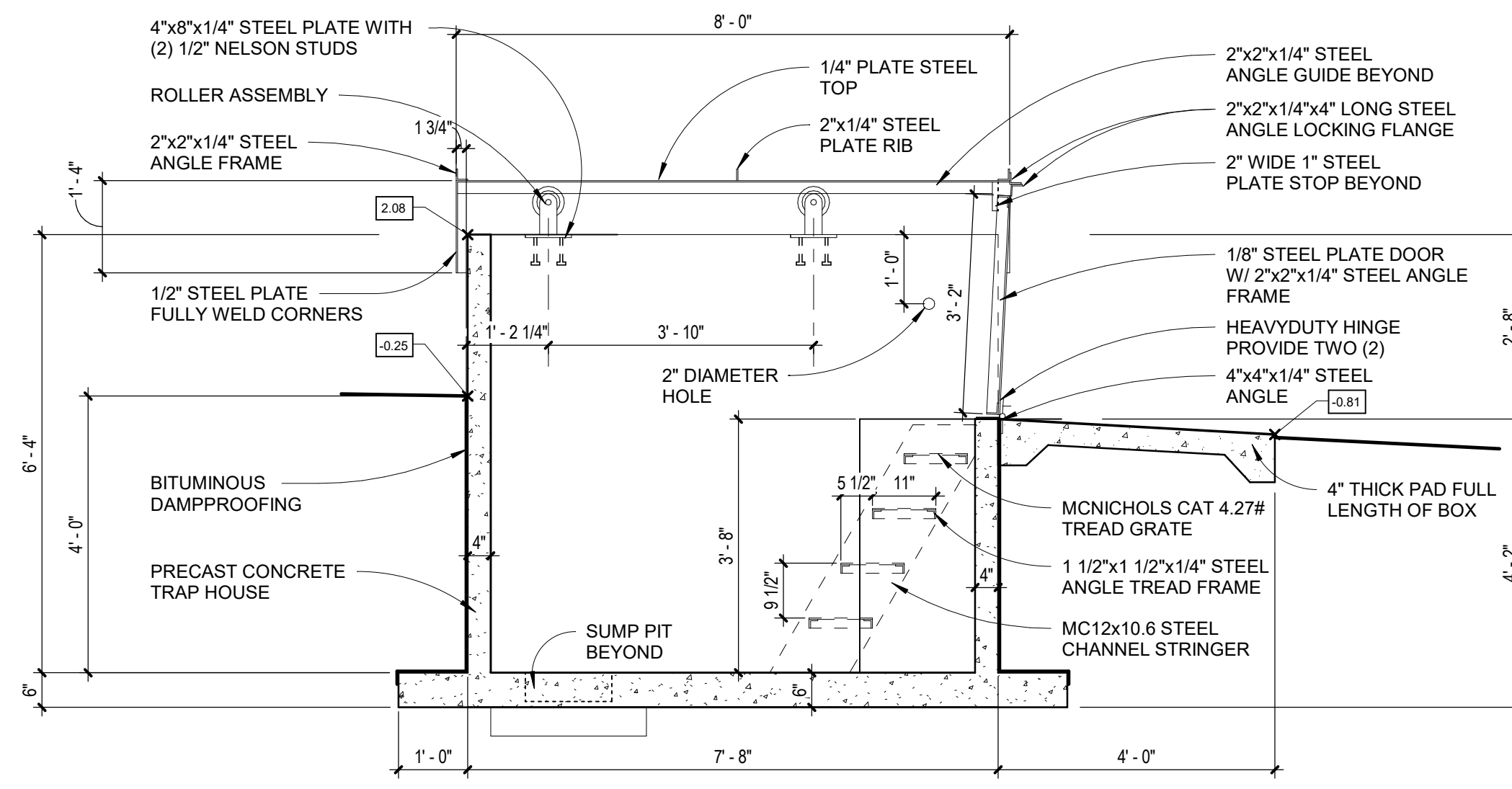

1 trap house section  
SCALE: 1/2" = 1'-0"

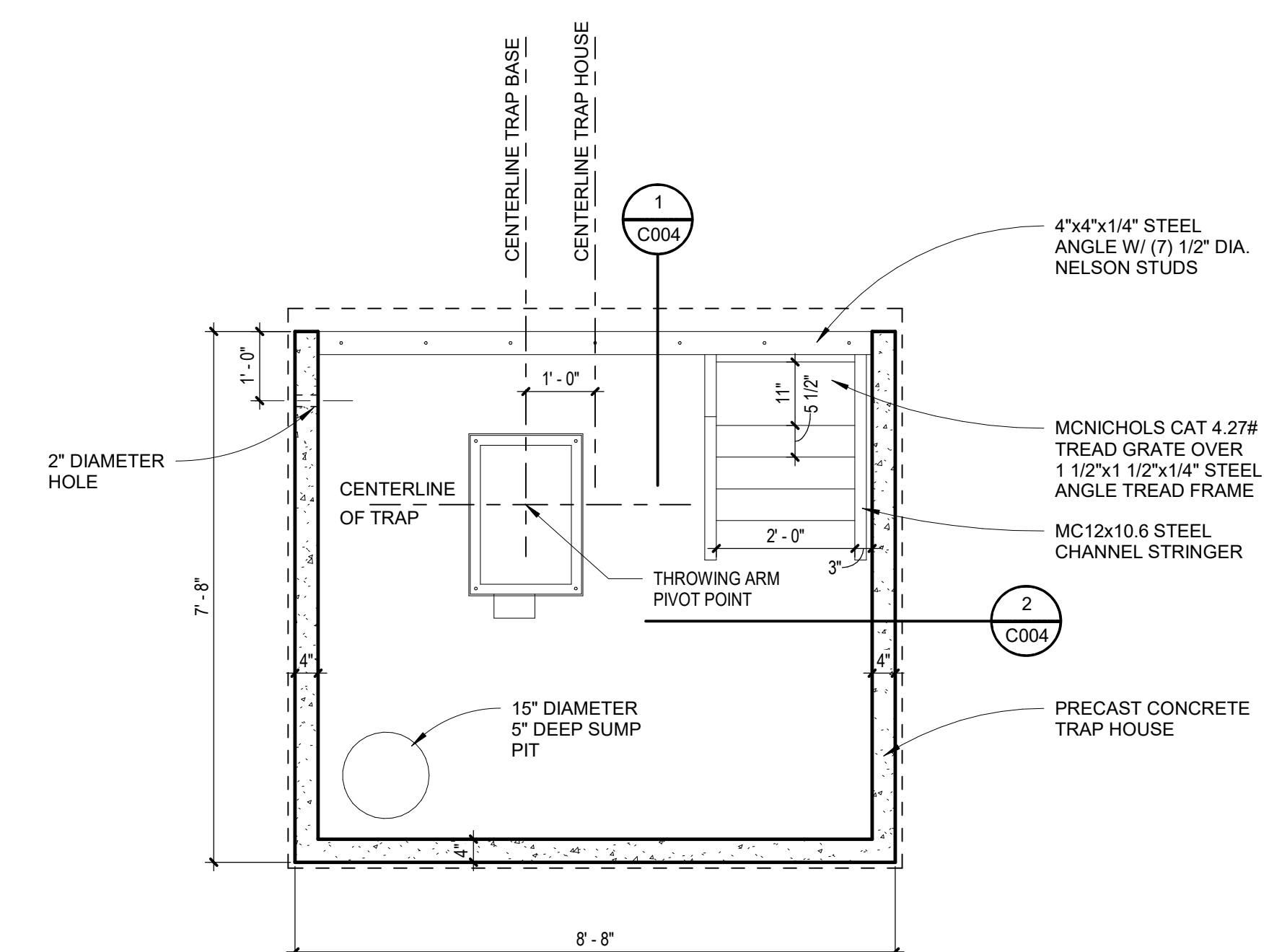

n trap house plan  
SCALE: 1/2" = 1'-0"

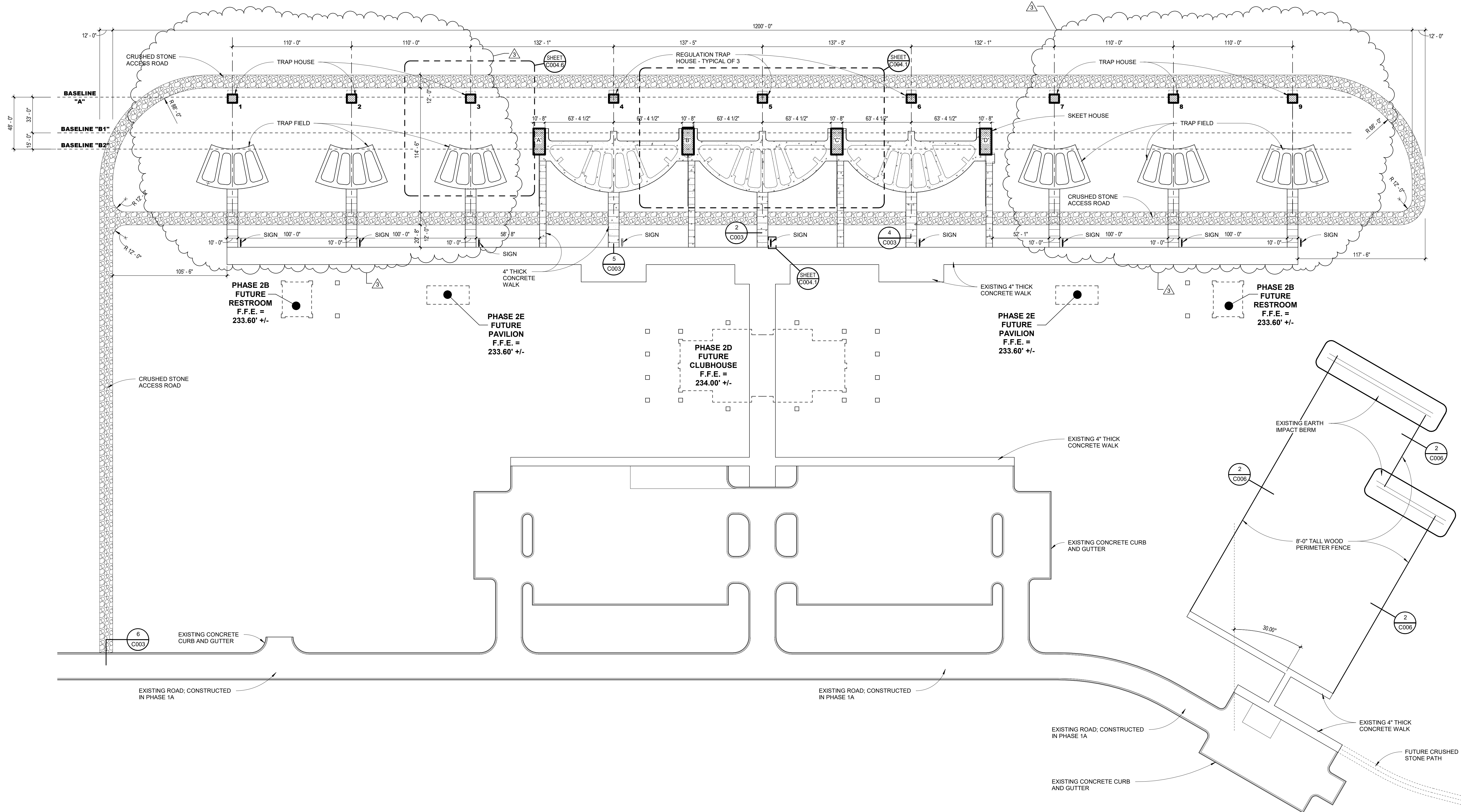

n trap/skeet layout site plan  
SCALE: 1" = 40'-0"



CITY OF JONESBORO  
**JONESBORO SHOOTING  
SPORTS COMPLEX**  
PHASE 1C  
Jonesboro, Arkansas

**BRACKETT  
KRENNERICH**  
architects

Revision	Schedule	Issued	By
1	Proposed Request	03.10.22	AKC
2	Proposed Request	03.10.22	AKC

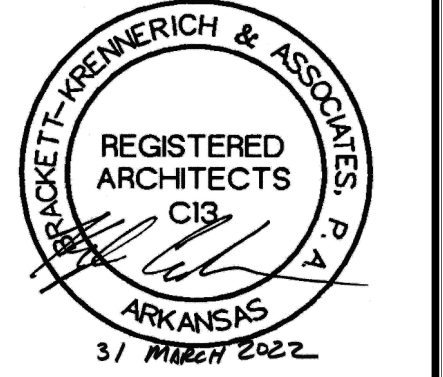

Commission Number  
12015-1C  
**C004**  
REVISED 03.31.22  
Date: January 17, 2020

T:\Projects\Current\2015 - Shooting Complex City of Jonesboro\1-BIM\4-Change  
4/1/2022 2:16:26 PM Site Package CD 03.10.22 - trap fields add.ctb.rvt







Legislation Details (With Text)

<b>File #:</b>	RES-22:073	<b>Version:</b>	1	<b>Name:</b>	DONATION OF RIGHT-OF-WAY TO THE ARKANSAS STATE HIGHWAY AND TRANSPORTATION DEPARTMENT FOR ROAD MAINTENANCE PURPOSES
<b>Type:</b>	Resolution	<b>Status:</b>			To Be Introduced
<b>File created:</b>	4/6/2022	<b>In control:</b>			Finance & Administration Council Committee
<b>On agenda:</b>		<b>Final action:</b>			
<b>Title:</b>	A RESOLUTION TO THE CITY OF JONESBORO, ARKANSAS AUTHORIZING THE DONATION OF RIGHT-OF-WAY TO THE ARKANSAS STATE HIGHWAY AND TRANSPORTATION DEPARTMENT FOR ROAD MAINTENANCE PURPOSES				
<b>Sponsors:</b>	Engineering				
<b>Indexes:</b>	Donation, Right-of-way				
<b>Code sections:</b>					
<b>Attachments:</b>	<a href="#">ROW plans</a> <a href="#">Agreement for Donation</a>				

Date	Ver.	Action By	Action	Result
------	------	-----------	--------	--------

A RESOLUTION TO THE CITY OF JONESBORO, ARKANSAS AUTHORIZING THE DONATION OF RIGHT-OF-WAY TO THE ARKANSAS STATE HIGHWAY AND TRANSPORTATION DEPARTMENT FOR ROAD MAINTENANCE PURPOSES

WHEREAS, the City of Jonesboro is owner of certain real property, which is described below:

Part of the Northwest Quarter of Section 23, Township 14 North, Range 3 East, Craighead County, Arkansas, more particularly described as follows:

Commencing at an Axle found at the Quarter Corner of Sections 22 and 23; thence North 88°10'33" East along the South line of said Northwest Quarter a distance of 398.98 feet to the Southwesterly Right of Way of U.S. Highway 63 as established by AHTD Job 100807 for the POINT OF BEGINNING; thence North 40°19'18" West along said right of way line a distance of 327.37 feet to a point; thence 25°42'26" West along said right of way line a distance of 107.07 feet to a point; thence North 89°24'12" East a distance of 115.09 feet to a point on the Southwesterly Right of Way of U.S. 63 as established by AHTD Job 10743; thence South 26°38'23" East along said right of way a distance of 112.07 feet to a point; thence South 43°06'09" East along said right of way line a distance of 332.56 feet to a point on the South line of said Northwest Quarter; thence South 88°10'33" West along said South line a distance of 134.36 feet to the point of beginning and containing 0.98 acres (42,833 sq. ft.) more or less as shown on AHTD plans referenced as Job 100807.

WHEREAS, the described property was donated to the City of Jonesboro as right-of-way for the purpose of constructing Parker Road Extension from Strawfloor Road to Washington Avenue;

WHEREAS, the Arkansas State Highway and Transportation Department constructed Parker Road Extension and desires to maintain the frontage road in accordance with their standards; and,



WHEREAS, the City of Jonesboro desires to donate the above described property to the Arkansas State Highway and Transportation Department for maintenance purposes.

NOW THEREFORE BE IT RESOLVED BY THE CITY COUNCIL FOR THE CITY OF JONESBORO, ARKANSAS THAT:

Section 1. The Mayor and City Clerk are hereby authorized by the City Council for the City of Jonesboro, Arkansas to execute all documents necessary to effectuate this donation of right-of-way.

100807

**RIGHT OF WAY SIGNS AND SYMBOLS**

- SECTION CORNER
- QUARTER CORNER
- QUARTER QUARTER CORNER
- SECTION CENTER
- STATE LINE OR CITY LIMITS
- COUNTY LINE
- TOWNSHIP LINE
- QUARTER SECTION LINE
- PROPERTY LINE
- EXISTING R/W LINE
- PROPOSED R/W LINE
- EXISTING CONTROL OF ACCESS
- PROPOSED CONTROL OF ACCESS
- PROPOSED R/W & CONTROL OF ACCESS
- EXISTING R/W DIMENSION
- PROPOSED R/W DIMENSION
- TEMPORARY & PERMANENT EASEMENT LINE
- EXISTING BRIDGE OR SEPARATION STRUCTURE
- PROPOSED BRIDGE OR SEPARATION STRUCTURE
- EXISTING CULVERT
- RAILROAD
- PAVED ROADS
- GRAVEL ROAD
- DRIVEWAY
- FENCE
- CONSTRUCTION LIMITS
- LEVEE
- TRAIL
- RESIDENTIAL & COMMERCIAL BUILDING
- HEDGE ROW
- SMALL STREAM
- LARGE STREAM
- POND OR LAKE
- TELEPHONE POLES
- POWER POLES
- TRANSMISSION LINES
- TREES
- DECIDUOUS WOODS
- EVERGREEN WOODS
- SET AHTD R/W MONUMENT
- TEMPORARY EASEMENT POINT
- PERMANENT EASEMENT POINT
- EXISTING R/W POINT
- PROPERTY LINE POINT
- FOUND MONUMENT
- SURVEY CALCULATED POINT

"THIS IS A FULLY CONTROLLED ACCESS FACILITY"

STATE OF ARKANSAS  
STATE HIGHWAY COMMISSION



# RIGHT OF WAY MAP PARKER ROAD EXTENSION (JONESBORO) (S)

CRAIGHEAD COUNTY  
ROUTE 63 SECTION 6  
JOB 100807

LAYOUT  
NOT TO SCALE

END JOB 100807  
STA. 112+27.13

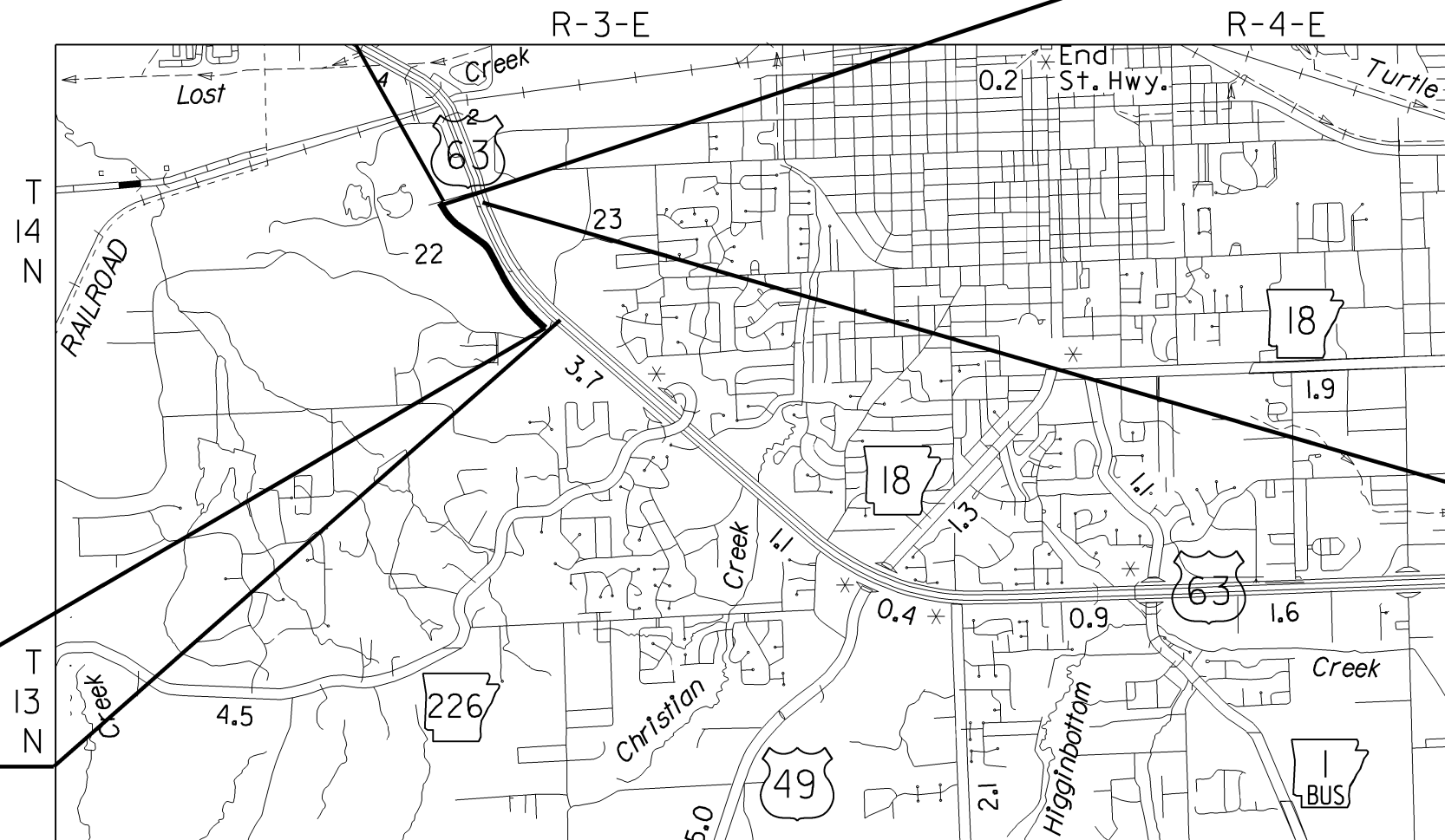

END R/W ACO.  
JOB 100807  
U.S. HWY. 63  
STA. 450+37.24

BEGIN JOB 100807  
STA. 73+74.43

BEGIN R/W ACO.

JOB 100807  
U.S. HWY. 63  
STA. 415+07.03

7/2015

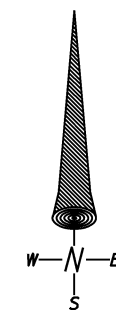

SURVEY CONTROL COORDINATES

Project Name: s100807  
 Date: 10/2/2014  
 Coordinate System: ARKANSAS STATE PLANE - NORTH ZONE BASED ON GPS CONTROL,  
 PROJECTED TO GROUND.  
 Units: U.S. SURVEY FOOT

Point Name	Northing	Easting	Elev	Feature	Description
44	548120.6678	1683186.3359	320.93	CTL	RBC
59	548516.1897	1682101.0725	349.79	CTL	REBAR+CAP
903	547855.4547	1683305.3072	327.68	BM	SQ CUT SE CRNR DI
904	547024.9376	1683875.3479	354.24	BM	SQR IN NORTH HW
905	545402.1253	1685238.0397	389.13	BM	CHSLD SQ NE COR. OF DI

\*Note - Rebar and Cap - Standard -\*' Rebar with 2' Aluminum Cap stamped  
 \*(standard markings common to all caps), or as indicated  
 (other markings indicated in the point description of the individual point).  
 ALL DISTANCES ARE GROUND.  
 USE CAF = 1.0 FOR STAKEOUT FOR THIS PROJECT.  
 A PROJECT CAF OF 0.999930642 HAS BEEN USED TO COMPUTE THE ABOVE GROUND COORDINATES.  
 THIS CAF IS INTENDED FOR USE WITHIN THE PROJECT LIMITS.  
 GRID DISTANCE = GROUND DISTANCE X CAF.  
 GRID COORDINATES ARE STORED UNDER 100807gi.ct1  
 HORIZONTAL DATUM: NAD 83 (1997)  
 VERTICAL DATUM: NAVD 88 POSITIONAL ACCURACY THIRD ORDER, UNLESS SPECIFIED OTHERWISE  
 AT A SPECIFIC POINT.

BASIS OF BEARING:  
 ARKANSAS STATE PLANE GRID BEARINGS - 0301-NORTH ZONE  
 DETERMINED FROM GPS CONTROL POINTS: H 315 - 160016  
 CONVERGENCE ANGLE: 00-43-37.34557 RIGHT AT PN:707  
 GRID AZIMUTH = ASTRONOMICAL AZIMUTH - CONVERGENCE ANGLE.

ALIGNMENT NAME: PARKER RD.

POINT	STATION	TYPE	NORTHING	EASTING
8001	64+29.06	POB	545312.9398	1685188.9903
8002	65+00.98	PC	545357.3305	1685132.4072
8003	67+47.59	PI	545509.5482	1684938.3814
8004	69+93.89	PT	545677.8745	1684758.1523
8005	76+54.25	PC	546128.6106	1684275.5431
8006	83+11.37	PI	546577.1352	1683795.3018
8007	89+55.75	PT	547160.3597	1683492.5560
8008	95+84.81	PC	547718.6822	1683202.7365
8009	97+60.90	PI	547874.9699	1683121.6092
8010	99+30.14	PT	547975.8203	1682977.2600
8011	105+52.57	PC	548332.2978	1682467.0267
8012	107+96.30	PI	548471.8867	1682267.2304
8013	110+32.87	PT	548680.7048	1682141.5380
8014	112+45.77	POE	548863.1105	1682031.7438

ALIGNMENT NAME: WASHINGTON AVE.

POINT	STATION	TYPE	NORTHING	EASTING
8015	10+00.00	POB	548796.8793	1681801.4466
8016	28+46.92	POE	549307.3443	1683576.4214

ALIGNMENT NAME: HWY. 63

POINT	STATION	TYPE	NORTHING	EASTING
8017	412+22.15	POB	545755.5159	1684854.7095
8018	414+34.00	PC	545898.5591	1684698.4493
8019	430+49.03	PI	546989.0674	1683507.1792
8020	445+82.38	PT	548541.1892	1683060.8045
8021	465+12.49	PC	550396.1149	1682527.3463
8022	472+67.15	PI	551121.3740	1682318.7691
8023	479+49.88	PT	551508.1711	1681670.7775
8024	484+84.41	POE	551782.1461	1681211.7941

PARKER ROAD EXTENSION  
 (JONESBORO) (S)  
 ARKANSAS STATE HIGHWAY COMMISSION  
 SURVEY CONTROL DETAILS  
 JOB 100807 CRAIGHEAD COUNTY

NO.	DATE	DESCRIPTION	BY	CK'D
	7/2015	REVISIONS		
DESIGNED:	RNF	REVIEWED:	DWY	

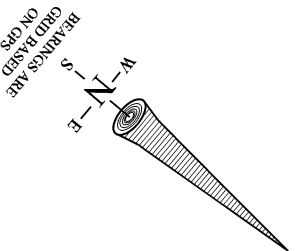

SE 1/4  
Sec 22  
T-14-N, R-3-E

SW 1/4 SW 1/4  
Sec 23  
T-14-N, R-3-E

NW 1/4 SW 1/4  
Sec 23  
T-14-N, R-3-E

SW 1/4 NE 1/4  
Sec 22  
T-14-N, R-3-E

NW 1/4 NE 1/4  
Sec 22  
T-14-N, R-3-E

SE 1/4 NE 1/4  
Sec 22  
T-14-N, R-3-E

NE 1/4 NE 1/4  
Sec 22  
T-14-N, R-3-E

NE 1/4 SW 1/4  
Sec 23  
T-14-N, R-3-E

NW 1/4  
Sec 23  
T-14-N, R-3-E



STRAWFLOOR DR.

PARKER RD.

WASHINGTON AVE.

PARKER ROAD EXTENSION  
(JONOSBORO) (S)  
ARKANSAS STATE HIGHWAY COMMISSION  
RIGHT OF WAY MAP  
JOB 100807 CRAIGHEAD COUNTY

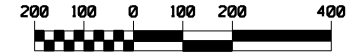

NO.	DATE	DESCRIPTION	BY	CK'D
DESIGNED:	RNF	REVIEWED:	DWY	

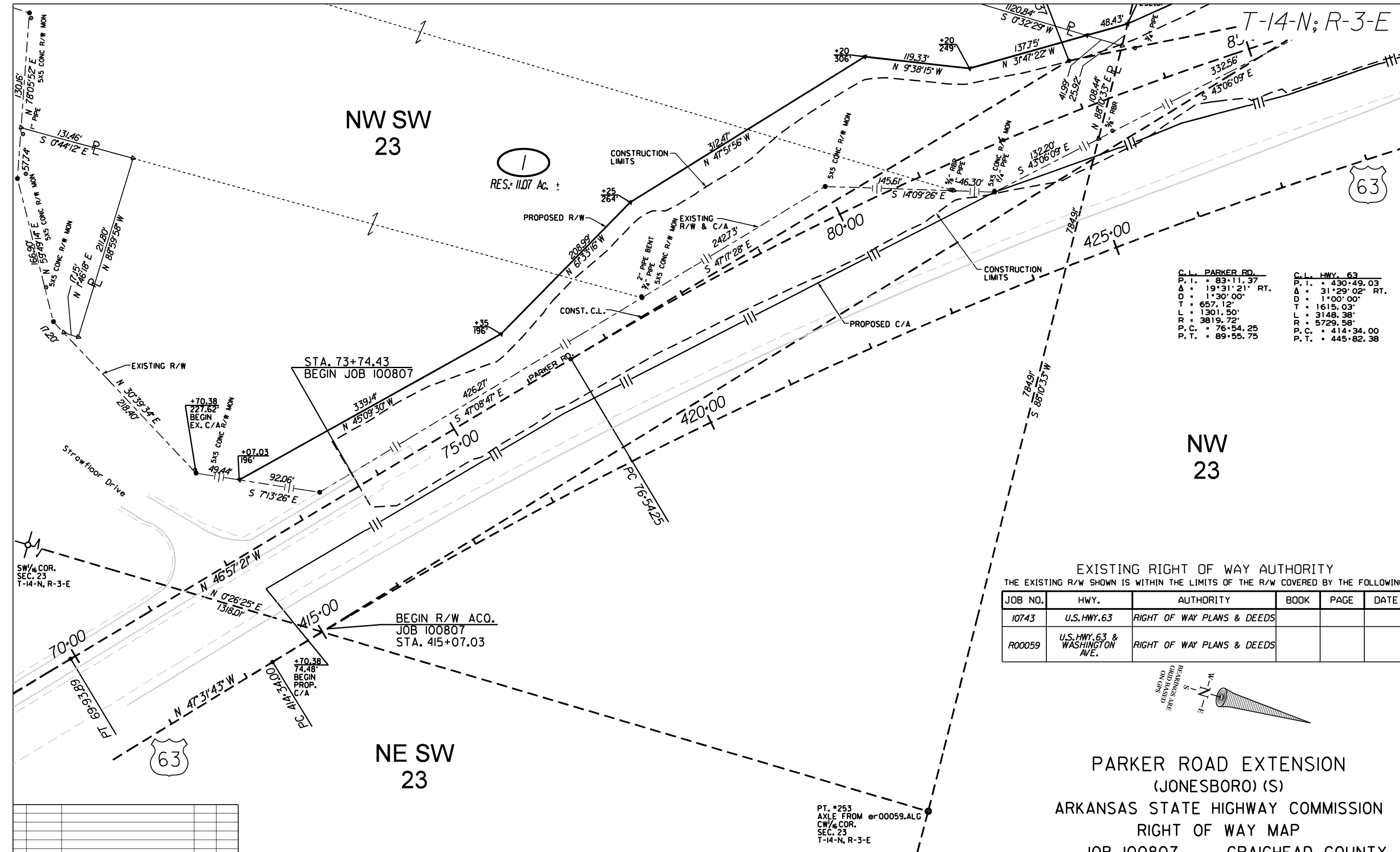

C.L. PARKER RD.		C.L. HWY. 63	
P.I.	= 83+11.37	P.I.	= 430+49.03
Δ	= 19°31'21" RT.	Δ	= 31°29'02" RT.
D	= 1°30'00"	D	= 1°00'00"
T	= 657.12'	T	= 1615.03'
L	= 1301.50'	L	= 3148.38'
R	= 3819.72'	R	= 5729.58'
P.C.	= 76+54.25	P.C.	= 414+34.00
P.T.	= 89+55.75	P.T.	= 445+82.38

EXISTING RIGHT OF WAY AUTHORITY  
 THE EXISTING R/W SHOWN IS WITHIN THE LIMITS OF THE R/W COVERED BY THE FOLLOWING:

JOB NO.	HWY.	AUTHORITY	BOOK	PAGE	DATE
10743	U.S. HWY. 63	RIGHT OF WAY PLANS & DEEDS			
R00059	U.S. HWY. 63 & WASHINGTON AVE.	RIGHT OF WAY PLANS & DEEDS			

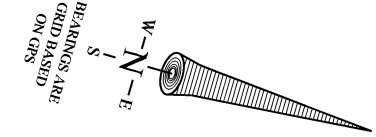

PARKER ROAD EXTENSION  
 (JONESBORO) (S)  
 ARKANSAS STATE HIGHWAY COMMISSION  
 RIGHT OF WAY MAP  
 JOB 100807 CRAIGHEAD COUNTY

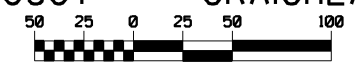

NO.	DATE	DESCRIPTION	BY	CK'D	1	5	13.32	2.25	580,238	98,137	REMARKS
DESIGNED:	7/20/15	REVISIONS	RNF	DWY	TRACT	OWNERSHIP	TITLE	AREA IN ACRES:	AREA IN SQ. FT.:		
					1	KARMA HOLDINGS, LLC					

SI/16 COR.  
SEC. 22 & 23  
T-14-N, R-3-E

SE  
22

SE NE  
22

C.L. PARKER RD.  
P.I. = 97°60.90  
Δ = 27°37'35" LT.  
D = 8°00'00"  
T = 176.09'  
L = 345.33'  
R = 716.20'  
P.C. = 95+84.81  
P.T. = 99+30.14

NW SW  
23

2  
RES: 468 Ac. ±

3  
RES: 253 Ac. ±

4  
RES: 57.63 Ac. ±

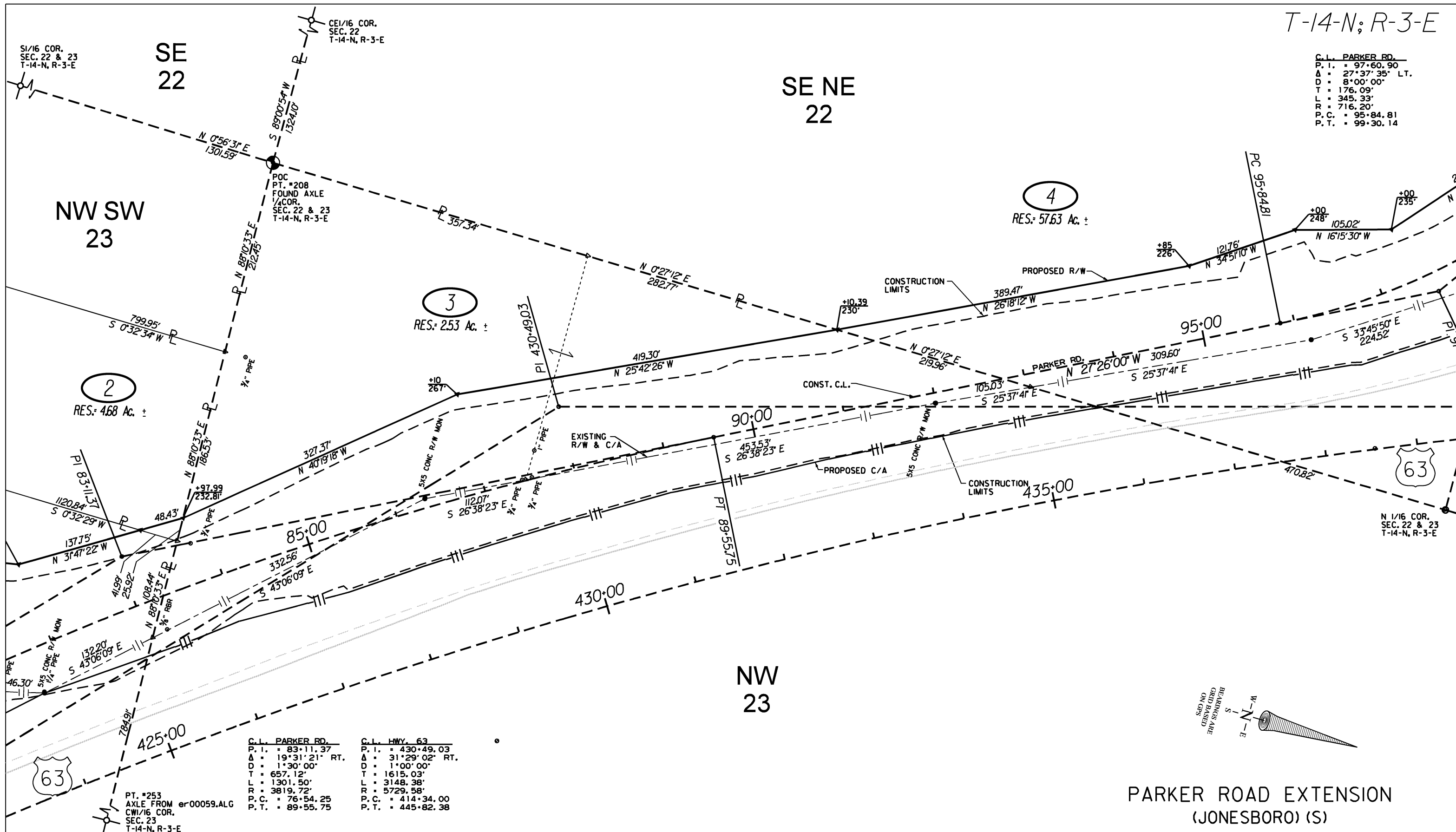

C.L. PARKER RD.  
P.I. = 83°11.37  
Δ = 19°31'21" RT.  
D = 1°30'00"  
T = 657.12'  
L = 1301.50'  
R = 3819.72'  
P.C. = 76+54.25  
P.T. = 89+55.75

C.L. HWY. 63  
P.I. = 430°49.03  
Δ = 31°29'02" RT.  
D = 1°00'00"  
T = 1615.03'  
L = 3148.38'  
R = 5729.58'  
P.C. = 414+34.00  
P.T. = 445+82.38

PARKER ROAD EXTENSION  
(JONESBORO) (S)  
ARKANSAS STATE HIGHWAY COMMISSION  
RIGHT OF WAY MAP  
JOB 100807 CRAIGHEAD COUNTY

NO.	DATE	DESCRIPTION	BY	CK'D			
	7/2015	REVISIONS					
DESIGNED:	RNF	REVIEWED:	DWY				
TRACT	OWNERSHIP	TITLE	PARCEL TO ACQUIRE	AREA IN ACRES:	PARCEL TO ACQUIRE	AREA IN SQ. FT.:	REMARKS
4	WILLIAM B. LACY JR., FAMILY TRUST	3	59.23	1.60	2,580,161	69,887	
3	ARKANSAS STATE HIGHWAY COMMISSION	7 & 9	4.52	1.99	196,754	86,476	
2	JAMES M. LAWSON JR. 1/2 INTEREST, MARCELLA RANSONE, LIFE ESTATE	4 & 8	4.69	0.01	204,157	544	REMAINDERMAN: RANDY ALLEN RANSON & JEFFREY DALE RANSONE 1/2 INTEREST



C.L. PARKER RD.  
 P. I. = 97+60.90  
 Δ = 27°37'35" LT.  
 D = 8°00'00"  
 T = 176.09'  
 L = 345.33'  
 R = 716.20'  
 P. C. = 95+84.81  
 P. T. = 99+30.14

NE1/16 COR.  
 SEC. 22  
 T-14-N, R-3-E

SE NE  
 22

(5E-1)  
 TCE

(6)  
 RES. #1= 0.71 AC. ±

NE NE  
 22

T-14-N, R-3-E

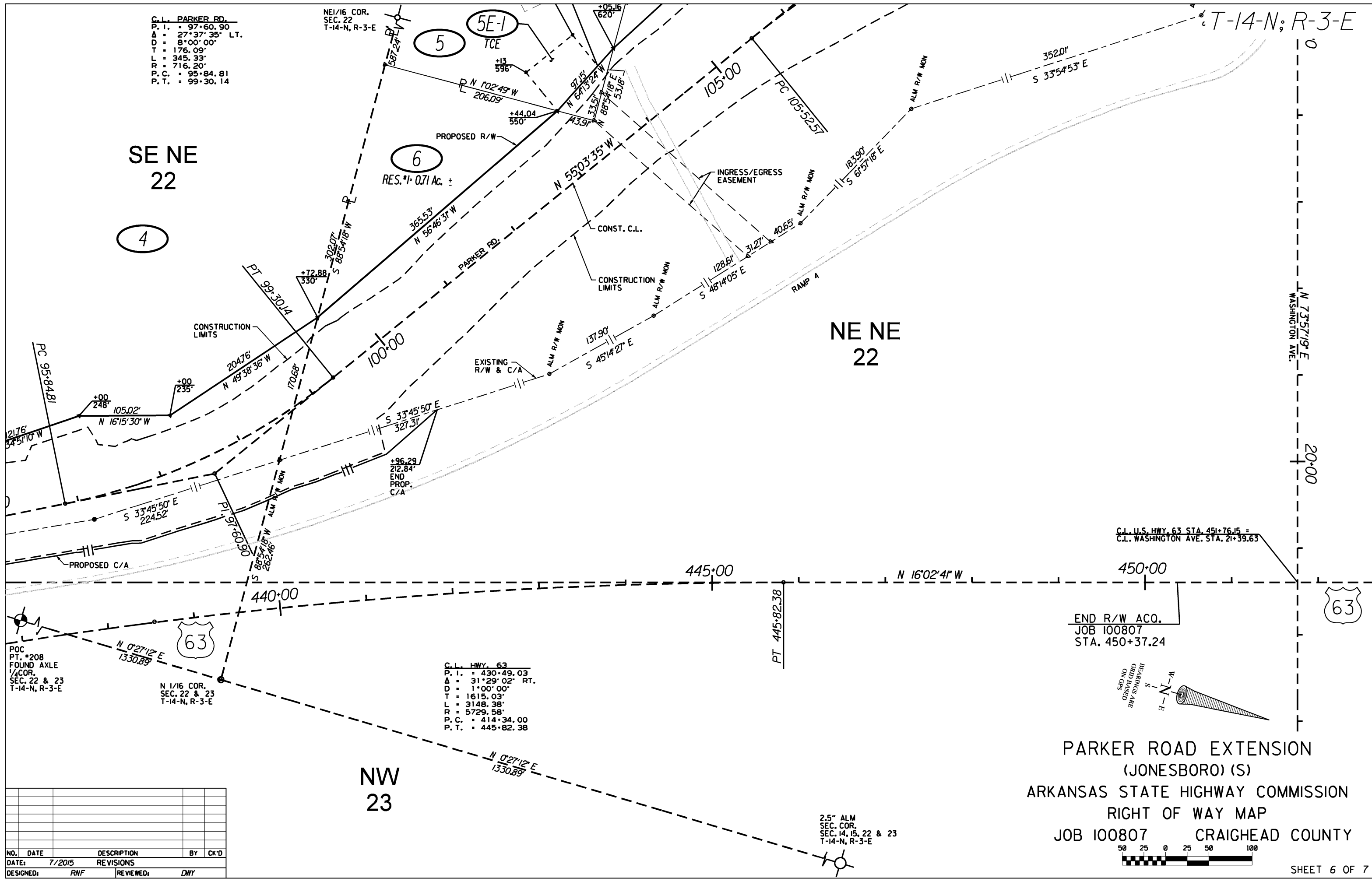

C.L. U.S. HWY. 63 STA. 451+76.15 =  
 C.L. WASHINGTON AVE. STA. 21+39.63

END R/W ACQ.  
 JOB 100807  
 STA. 450+37.24

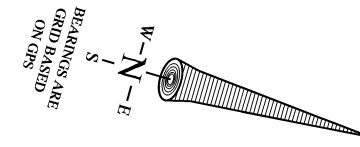

C.L. HWY. 63  
 P. I. = 430+49.03  
 Δ = 31°29'02" RT.  
 D = 1°00'00"  
 T = 1615.03'  
 L = 3148.38'  
 R = 5729.58'  
 P. C. = 414+34.00  
 P. T. = 445+82.38

PARKER ROAD EXTENSION  
 (JONESBORO) (S)  
 ARKANSAS STATE HIGHWAY COMMISSION  
 RIGHT OF WAY MAP  
 JOB 100807 CRAIGHEAD COUNTY



NO.	DATE	DESCRIPTION	BY	CK'D
	7/2015	REVISIONS		
DESIGNED:	RNF	REVIEWED:	DWY	

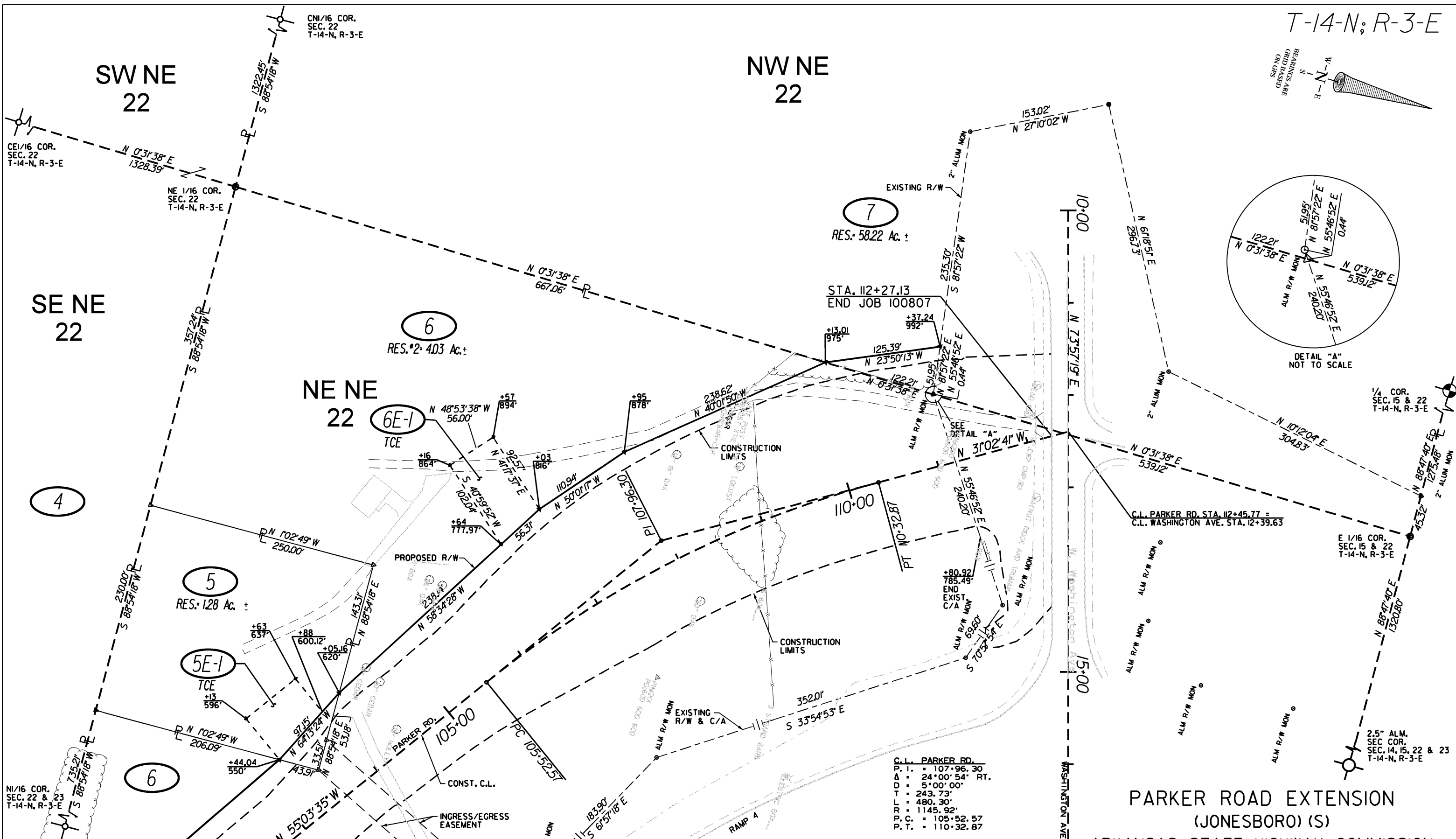
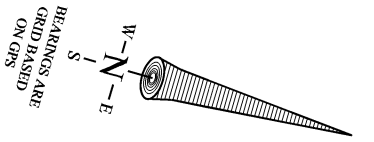

**C.L. PARKER RD.**

P. I.	107.96.30
Δ	24°00'54" RT.
D	5°00'00"
T	243.73'
L	480.30'
R	1145.92'
P. C.	105.52.57
P. T.	110.32.87

NO.	DATE	DESCRIPTION	BY	CK'D	TRACT	OWNERSHIP	TITLE	PARCEL TO ACQUIRE	PARCEL TO ACQUIRE	REMARKS
REVISIONS					AREA IN ACRES:	AREA IN SQ. FT.:				
7		RAZORBACK CONCRETE COMPANY	1 REV.		58.29	0.07	2,539,189	3,161		
6		BIG CREEK CROSSING, LLC	2		12.29	7.55	535,233	328,674		TCE 6E-1 • 0.12 AC. ± OR 5,425 S.F. ±
5		ARKANSAS STATE HIGHWAY COMMISSION	6		1.32	0.04	57,500	1,903		TCE'S 5E-1 • 0.08 AC. ± OR 3,559 S.F. ±
2	1/20/22	REV. OWNERSHIP TR. 7	AM	AM						
1	12/9/15	Added bearings & distances to TCE 6E-1	RA	RA						
NO. DATE DESCRIPTION BY CK'D										
DATE: 7/2015 REVISIONS										
DESIGNED: RNF REVIEWED: DWY										

**PARKER ROAD EXTENSION  
(JONESBORO) (S)**  
**ARKANSAS STATE HIGHWAY COMMISSION**  
**RIGHT OF WAY MAP**  
**JOB 100807 CRAIGHEAD COUNTY**

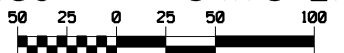



JOB NAME: Parker Road Extension  
(Jonesboro) (S)

JOB NO. 100807  
TRACT NO. 3

**AGREEMENT FOR DONATION**  
**REAL ESTATE FOR HIGHWAY PURPOSES**

Grantor: City of Jonesboro

Address:

Grantee: Arkansas State Highway and Transportation Department

IN CONSIDERATION of the benefits that will inure to the Grantor(s) and the public, the undersigned does hereby agree, without any remuneration or monetary consideration, to donate to the Arkansas State Highway and Transportation Department, Grantee, and unto its successors and assigns, upon the terms and conditions hereinafter set forth, the following lands situated in the County of Craighead, State of Arkansas, to-wit:

LEGAL DESCRIPTION

Part of the Northwest Quarter of Section 23, Township 14 North, Range 3 East, Craighead County, Arkansas, more particularly described as follows:

Commencing at an Axle found at the Quarter Corner of Sections 22 and 23; thence North 88°10'33" East along the South line of said Northwest Quarter a distance of 398.98 feet to the Southwesterly Right of Way of U.S. Highway 63 as established by AHTD Job 100807 for the POINT OF BEGINNING; thence North 40°19'18" West along said right of way line a distance of 327.37 feet to a point; thence North 25°42'26" West along said right of way line a distance of 107.07 feet to a point; thence North 89°24'12" East a distance of 115.09 feet to a point on the Southwesterly Right of Way of U.S. Highway 63 as established by AHTD Job 10743; thence South 26°38'23" East along said right of way line a distance of 112.07 feet to a point; thence South 43°06'09" East along said right of way line a distance of 332.56 feet to a point on the South line of said Northwest Quarter; thence South 88°10'33" West along said South line a distance of 134.36 feet to the point of beginning and containing 0.98 acres (42,833 sq. ft.) more or less as shown on AHTD plans referenced as Job 100807.

RA

3/24/16

- Uncontrolled Access
- Partially Controlled Access – Access break from Station \_\_\_\_\_ to Station \_\_\_\_\_
- Fully Controlled Access
- Fully Controlled Access with a frontage road
- Maintenance Agreement

PREAUDITED AND ACCEPTED:

Property Manager to Negotiator

\_\_\_\_\_

By \_\_\_\_\_ Date \_\_\_\_\_

In Accordance with Public Law 91-646 as Amended by Public Law 100-17, Title III, Section 301, et seq. of the Uniform Relocation Assistance and Real Property Acquisition Policies Act, the Grantor/s is/are entitled to receive an appraisal to establish the value of the lands donated as well as just compensation for such donation. Grantor/s does/do hereby waive receipt of the authorized appraisal of the (lands) donated and do hereby waive all of her/his/their right/s to any compensation or monetary remuneration for the property described herein.

Closing costs will not accrue to the Grantor(s) as the Grantee's Attorney will prepare the necessary documents for closing and the Grantee will pay the cost of recording all instruments conveying title to the Arkansas State Highway and Transportation Department

WITNESS my/our hands/s on this \_\_\_\_\_ day of \_\_\_\_\_, 20\_\_\_\_.

\_\_\_\_\_  
Signature

\_\_\_\_\_  
Signature

\_\_\_\_\_  
Signature

\_\_\_\_\_  
Signature

### ACKNOWLEDGMENT

STATE OF ARKANSAS

COUNTY OF \_\_\_\_\_

BE IT REMEMBERED, that on this day before the undersigned, a Notary Public, within and for the County and State aforesaid, duly commissioned and acting, appeared in person \_\_\_\_\_, to me well known as the Grantor(s) in the foregoing instrument, and stated that he/she/they had executed the same for the consideration and purposes therein mentioned and set forth.

WITNESS my hand and seal as such Notary Public this \_\_\_\_\_ day of \_\_\_\_\_, 20\_\_\_\_.

MY COMMISSION EXPIRES: \_\_\_\_\_

\_\_\_\_\_  
NOTARY PUBLIC



\* J B 2 0 1 6 R - 0 1 9 9 8 1 2 \*

JB2016R-019981

CANDACE EDWARDS

CRAIGHEAD COUNTY

RECORDED ON:

12/27/2016 02:53PM

I certify under penalty of false swearing that documentary stamps or a documentary symbol to the legally correct amount has been placed on this instrument. Exempt or no consideration paid if none shown.

This instrument was prepared by:  
Alec Farmer, President  
Farmer Enterprises, Inc.  
2504 Alexander Drive #116  
Jonesboro, AR 72401

GRANTEE OR AGENT:

*City of Jonesboro*  
BY *Delinda Garrison*

GRANTEE'S ADDRESS:

*300 S. Church*  
*Jonesboro, AR 72401*

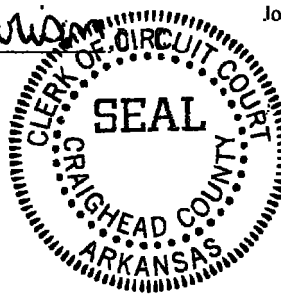

### CORPORATE QUITCLAIM DEED

#### KNOW ALL MEN BY THESE PRESENTS:

That I, **Alec Farmer, President of Farmer Enterprises, Inc., an Arkansas Corporation**, hereinafter referred to as “Grantor,” for and in consideration of the mutual covenants and benefits inuring to the party hereto, does hereby grant, bargain, deliver and quitclaim to the **City of Jonesboro**, hereinafter referred to as “Grantee,” and unto its successors and assigns forever, the following lands, lying and being situated in the County of Craighead, State of Arkansas, to-wit:

#### **Job 100807 – Tract No. 3 (South Part)**

Part of the Northwest Quarter of Section 23, Township 14 North, Range 3 East, Craighead County, Arkansas, more particularly described as follows:

Commencing at an Axle found at the Quarter Corner of Sections 22 and 23; thence North 88°10'33" East along the South line of said Northwest Quarter a distance of 398.98 feet to the Southwesterly Right of Way of U.S. Highway 63 as established by AHTD Job 100807 for the POINT OF BEGINNING; thence North 40°19'18" West along said right of way line a distance of 327.37 feet to a point; thence 25°42'26" West along said right of way line a distance of 107.07 feet to a point; thence North 89°24'12" East a distance of 115.09 feet to a point on the Southwesterly Right of Way of U.S. 63 as established by AHTD Job 10743; thence South 26°38'23" East along said right of way a distance of 112.07 feet to a point; thence South 43°06'09" East along said right of way line a distance of 332.56 feet to a point on the South line of said Northwest Quarter; thence South 88°10'33" West along said South line a distance of 134.36 feet to the point of beginning and containing 0.98 acres (42,833

sq. ft.) more or less as shown on AHTD plans referenced as Job 100807, and subject to a driveway egress/ingress easement on the southwest corner of said property.

**TO HAVE AND TO HOLD** the same unto the said **Grantee** and unto its successors and assigns forever, with all tenements, appurtenances and hereditaments thereunto belonging.

**IN WITNESS WHEREOF**, Farmer Enterprises, Inc., an Arkansas Corporation, has caused these presents to be executed by its President on this 27<sup>th</sup> day of December, 2016.

**FARMER ENTERPRISES, INC.,  
an Arkansas Corporation**

Alec Farmer  
Alec Farmer, President

**ACKNOWLEDGMENT**

**STATE OF ARKANSAS**

**COUNTY OF CRAIGHEAD**

On this day appeared before the undersigned, a Notary Public within and for the County and State aforesaid, duly qualified, commissioned and acting, Alec Farmer, to me well known as the representative of the Grantor in foregoing Quitclaim Deed, and stated that he had executed the same for the consideration and purposes therein mentioned and set forth.

WITNESS my hand and official seal on this 27<sup>th</sup> day of December, 2016.

April Lanelle Leggett  
Notary Public

My Commissions Expires: 11/09/2026  
(SEAL)



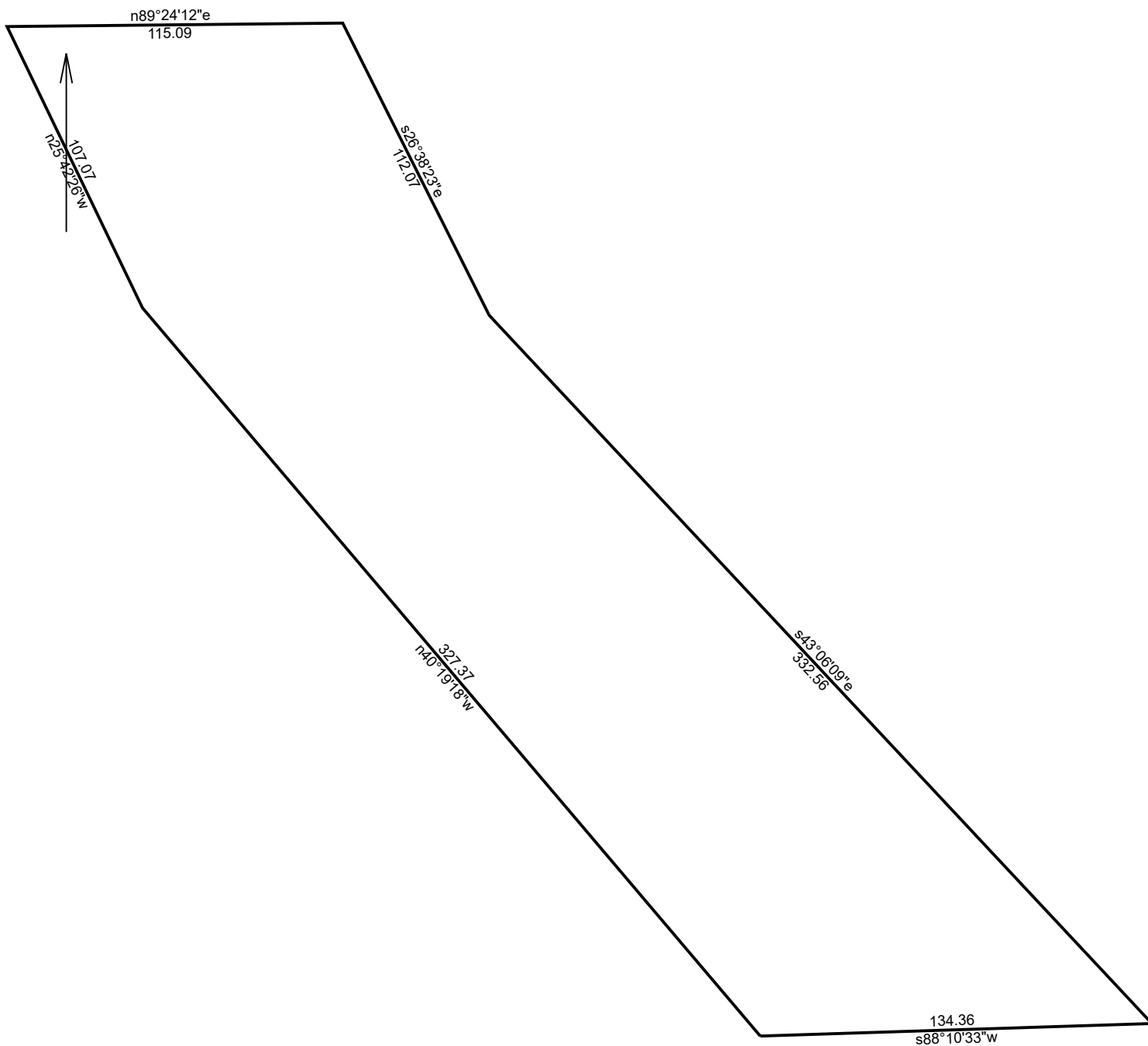

Deed JB2016R-019981

4/1/2022

Scale: 1 inch= 51 feet

File:

Tract 1: 0.9833 Acres (42833 Sq. Feet), Closure: n00.0000e 0.00 ft. (1/242406), Perimeter=1129 ft.

- 01 n40.1918w 327.37
- 02 n25.4226w 107.07
- 03 n89.2412e 115.09
- 04 s26.3823e 112.07
- 05 s43.0609e 332.56
- 06 s88.1033w 134.36