



Specifications

For

Dalton-Farmer Drive Sanitary Sewer Extension Project EDA Project No. 08-01-00349

**(Bid #2014:25)
Jonesboro, Arkansas**

City of Jonesboro • Engineering Department

P.O. Box 1845 • 300 South Church Street • Jonesboro, AR 72403 • 870.932.2438

TABLE OF CONTENTS

I. ADVERTISEMENT FOR BIDS

II. INSTRUCTIONS TO BIDDERS

III. PROPOSAL

IV. UNIT PRICE SCHEDULE

V. CERTIFICATION REGARDING LOBBYING

VI. NOTICE OF REQUIREMENTS FOR AFFIRMATIVE ACTIONS

VII. SUSPENSION AND DEBARMENT

VIII. BID BOND

IX. STATEMENT OF BIDDER'S QUALIFICATIONS

X. NOTICE OF AWARD

XI. NOTICE TO PROCEED

XII. CHANGE ORDER

XIII. CONTRACT

XIV. PERFORMANCE AND PAYMENT BOND

XV. GENERAL CONDITIONS

XVI. SUPPLEMENTAL GENERAL CONDITIONS

XVII. SPECIAL CONDITIONS

XVIII. TECHNICAL SPECIFICATIONS

ADVERTISEMENT FOR BIDS

Sealed bids for the Dalton-Farmer Drive Sanitary Sewer Extension Project will be received at the Purchasing Department, Room 421, of the City of Jonesboro City Hall, 300 South Church, Jonesboro, Arkansas until 2:00 P.M. (Local Time) on September 24, 2014 and then publicly opened and read in Room #101 for furnishing all labor, material, and equipment, and performing all work required to extend the sanitary sewer along Dalton-Farmer Drive. All Submissions shall be annotated on the outside of the envelope with the bid number 2014:25.

The project consists of the installing 3,566 LF of 12" PVC gravity sanitary sewer line and fifteen (15) pre-cast sewer manholes.

Proposals shall be accompanied by a cashier's or certified check upon a national or state bank in an amount not less than five percent (5%) of the total maximum bid price payable without recourse to the City of Jonesboro or a bid bond in the same amount from a reliable surety company, as a guarantee that the Bidder will enter into a contract and execute performance and payment bonds within ten (10) days after notice of award of Contract to him. The notice of award of Contract shall be given by the Owner within sixty (60) days following the opening of bids.

The successful Bidder must furnish a performance and payment bond upon the form provided in the amount of one hundred percent (100%) of the contract price from an approved surety company holding a permit from the State of Arkansas to act as surety, or other surety or sureties acceptable to the Owner.

The attention of bidders is called to the fact that no contractor's license is required to submit a bid, but successful bidder must be licensed prior to entering into a contract with the City for the project.

Plans, specifications, proposal forms and other contract documents may be examined at City of Jonesboro Engineering Department, 300 South Church Street, Jonesboro, Arkansas 72401 and may be secured at the cost of \$25.00 Dollars per set from the City of Jonesboro, 300 South Church Street, Jonesboro, Arkansas 72401. No refunds will be made. Any addendum to this bid will be posted no later than 5 days before bid opening by clicking on "Purchasing" at www.jonesboro.org.

Proposals will be considered on the basis of cost, the bidder's financial responsibility, his equipment, and his past performance in completing similar work. The City of Jonesboro reserves the right to reject any or all bids, to waive any informalities, and to accept the proposal deemed to be for their best interest.

The City of Jonesboro hereby notifies all bidders that this contract is subject to applicable labor laws, non-discrimination provisions, wage rate laws and other federal laws including the Fair Labor Standards Acts of 1938. The Work Hours Act of 1962 and Title VI of the Civil Rights Act of 1964 also apply.

The City of Jonesboro encourages participation of small, minority, and woman owned business enterprises in the procurement of goods, services, and construction, either as a general contractor or subcontractor. It is further requested that whenever possible, majority contractors who require sub-contractors seek qualified small, minority, and women owned businesses to partner with them.

II. INSTRUCTION TO BIDDERS

1. PREPARATION OF BID

Each bid must be submitted on the prescribed form (Proposal) and Unit Price Schedule. All blank spaces must be filled in legibly with ink or typed. All blank spaces for bid prices on the Unit Price Schedule must be filled in with figures; the extended total for each item shall be entered. If the unit price and the extended total of any item are not in agreement, the unit price shall govern and the extended total be corrected to conform thereto. Erasures or other corrections on the Proposal form or Unit Price Schedule shall be initialed by the signer of the bid. All bids must be signed in ink by an individual authorized to bind the Bidder. All bids must be regular in every respect and no interlineations, excisions or special conditions shall be made or included in the Proposal by the Bidder.

There must be a bid on all items which may appear on the Unit Price Schedule. No bid will be considered which covers only a part of the work. A conditional bid will not be considered.

The bid form and Unit Price Schedule shall not be detached, but shall be **submitted in the original binding** as furnished by the Engineer. Submission must be at the place, and at or prior to the time specified in the Advertisement for Bids.

Each bid must be submitted in a sealed envelope clearly marked on the outside that it contains a bid for the Dalton-Farmer Drive Sanitary Sewer Extension Project, Bid Number 2014:25 and with the hour and date of bid opening shown thereon. The name and address of the Bidder shall appear in the upper left hand corner of the envelope. If forwarded by mail, the sealed envelope containing the bid must be enclosed in another envelope properly addressed as noted in the NOTICE TO CONTRACTORS.

A bid which obviously is unbalanced may be rejected.

2. INTERPRETATIONS AND ADDENDA

No oral interpretation will be made to any Bidder as to the meaning of the Contract Documents or any part thereof. Every request for such an interpretation shall be made in writing to the City of Jonesboro Engineering Department. Any inquiry received up to seven (7) days prior to the opening of bids will be given consideration. Every interpretation made to a Bidder will be in the form of an Addendum to the contract Documents. All such Addenda shall become part of the Contract and all Bidders shall be bound by such Addenda, whether or not received by the Bidders.

3. INSPECTION OF SITE

Each Bidder shall visit the site of the proposed work and fully acquaint himself with the existing conditions there relating to construction and labor, and shall fully inform himself as to the facilities involved, and the difficulties and restrictions attending the performance of the Contract. The Bidder shall thoroughly examine and familiarize himself with the Plans, Technical Specifications, and other Contract Documents. The Contractor by the execution of the Contract shall not be relieved of any obligation under it due to his failure to receive or examine any form or legal instrument or to visit the

site and acquaint himself with the conditions there existing. The Owner will be justified in rejecting any claim based on facts regarding which the contractor should have been on notice as a result thereof.

4. BID GUARANTY

The bids must be accompanied by a Bid Guaranty which shall not be less than five percent (5%) of the amount of the bid. At the option of the Bidder, the guaranty may be a certified check, or may be a bid bond (substantially in the form attached). No bid will be considered unless it is accompanied by the required guaranty. Certified check must be payable to the City of Jonesboro, Arkansas. Cash deposits will not be accepted. The Bid Guaranty shall insure the execution of the Contract and the furnishing of the surety bond or bonds by the successful Bidder, all as required by the Contract Documents.

Certified checks, or bid bonds, of unsuccessful Bidders, will be returned upon request as soon as feasible after the opening of the bids.

5. COLLUSION; SUBCONTRACTS

A Bidder submitting a Proposal to the Owner for the work contemplated by the Documents on which bidding is based shall not collude with any other person, firm, or corporation in regard to any bid submitted.

Before executing any subcontract, the successful Bidder shall submit the name of any proposed Subcontractor for prior approval of the Owner.

6. STATEMENT OF BIDDER'S QUALIFICATIONS

Each Bidder shall submit on the form furnished for that purpose (a copy of which is included in the Contract Documents), a statement of the Bidder's qualifications, his experience record in construction of work similar to that which here is involved, and his organization and equipment available for the work contemplated; and when specifically requested by the Owner, the Bidder shall provide a detailed financial statement. The Owner shall have the right to take such steps as it deems necessary to determine the ability of the Bidder to perform his obligations under the Contract, and the Bidder shall furnish the Owner all such information and data for this purpose as it may request. The right is reserved to reject any bid where an investigation of the available evidence or information does not satisfy the Owner that the Bidder is qualified to carry out properly the terms of the Contract.

7. BALANCED BIDS; VARIATIONS IN QUANTITIES

The lump sum price and unit price for each of the several items in the Proposal of each Bidder shall be balanced and shall include its pro rata share of overhead.

The Owner shall have the right to increase or decrease the extent of the work or to change the location, gradient, or the dimensions of any part of the work, provided that the length of the improvement is not increased or decreased in excess of 25% of the contract length, or that the

quantities of work to be done or the materials to be furnished are not increased or decreased in money value in excess of 25% of the total Contract. Such changes shall not be considered as a waiver of any conditions of the Contract nor invalidate any of the provisions thereof. The Contractor shall perform the work as increased or decreased within the qualifying limits named and no allowance will be made for anticipated profits on increases or decreases so incurred.

Increases or decreases in items of work, and the cost thereof, shall be done in accordance with the Section entitled, CHANGES IN THE WORK under GENERAL CONDITIONS.

8. TIME FOR RECEIVING BIDS

A bid received prior to the advertised time of opening will be kept securely, and will remain sealed until the time of opening. The officer whose duty it is to open them will decide when the specified time has arrived, and any bid received subsequent to that time will be returned unopened.

9. OPENING OF BIDS

At the time and place fixed for the opening of bids, the Owner first will cause the bid guarantees to be checked as stipulated above. The Owner then will cause the qualified bids to be opened and publicly read aloud, irrespective of any irregularities therein. Bidders and other persons properly interested may be present, in person or by representative.

10. WITHDRAWAL OF BIDS

Bids may be withdrawn on written request if the request is received prior to the time fixed for the opening of bids.

11. AWARD OF CONTRACT; REJECTION OF BIDS

The Contract will be awarded to the responsible Bidder submitting the lowest total bid complying with the conditions of the Notice to Contractors and other parts of these Contract Documents. The Bidder to whom the award is made will be notified at the earliest possible date. The Owner, however, reserves the right to reject any or all bids and to waive any informality in bids received whenever such rejection or waiver is in its interests.

The Owner reserves the right to consider as unqualified to do the work any Bidder who does not habitually perform with his own forces the major portions of such work as is involved in construction of these improvements.

12. EXECUTION OF AGREEMENT; PERFORMANCE AND PAYMENT BOND

Subsequent to the award and within ten (10) days after the prescribed forms are presented for signature, the successful Bidder shall execute and deliver to the Owner a Contract in the form included in the Contract Documents in such number of copies as the Owner may require.

Having satisfied all conditions of award as set forth elsewhere in these Documents, the successful Bidder shall, within the period specified above, furnish a surety bond in a penal sum not less than the amount of the Contract as awarded, as security for the faithful performance of the Contract, and for the payment of all persons, firms or corporations to whom the Contractor may become legally indebted for labor, materials, tools, equipment, or services of any nature, including utility and transportation services employed or used by him in performing the work. Such bond shall be as included in the Contract Documents and shall bear the same date as, or a date subsequent to, that of the Contract. The current power of attorney for the person who signs for any surety company shall be attached to such bond.

The failure of the successful Bidder to execute such Contract and to supply the required bond or bonds within ten (10) days after the prescribed forms are presented for signature, or within such extended period as the Owner may grant, based upon reasons determined insufficient by the Owner, shall constitute a default, and the Owner may either award the Contract to the next lowest responsible Bidder or readvertise for bids.

13. BONDS AND INSURANCE

Attention of Bidders is called to Act 82 of the 1935 Acts of the Arkansas General Assembly, which has certain requirements pertaining to performance bonds, labor bonds, employer's liability insurance, public liability insurance, workmen's collective insurance, and property damage insurance.

All companies furnishing bid bonds and performance bonds shall furnish evidence of being on the U.S. Treasury Department's most current list (Circular 570, as amended) and be authorized to transact business in the State of Arkansas.

14. LEGAL QUALIFICATIONS

The successful Bidder, if a corporation created under the laws of a state other than the State of Arkansas, will be required to qualify, or to have qualified, with the Secretary of State of Arkansas to do business in the State of Arkansas.

15. MODIFICATION OF BID

No modification of any bid already submitted will be considered unless such modification is received prior to the time set for opening of bids.

III. PROPOSAL

Place Jonesboro AR
Date 9/23/14

Proposal of Turnman Construction, Inc.

a corporation organized and existing under the laws of the State of Arkansas

or

Proposal of _____

a partnership consisting of _____

or

Proposal of _____

an individual doing business as _____

TO: City of Jonesboro

This bid results from your advertisement for bids for the Dalton-Farmer Drive Sanitary Sewer Extension Project.

The undersigned Bidder, having visited the site of the work, having examined the Plans, Specifications, and other Contract Documents including all Addenda, and being familiar with all of the conditions relating to the construction of the proposed project, hereby agrees to comply with all other conditions or requirements set forth in the Plans, Specifications, and other Contract Documents, and further proposes to furnish all material, supplies, equipment, and appliances specified for incorporation into the project and to furnish all labor, tools, equipment, and incidentals to complete the work in accordance with the Plans, Specifications, and other Contract Documents at and for the lump sum and unit prices proposed in the attached Unit Price Schedule.

The undersigned Bidder agrees to begin work within ten (10) calendar days after the issuance by the Owner of a "Work Order" or "Notice to Proceed" and to complete the work within ninety (90) calendar days thereafter (except as modified in the GENERAL CONDITIONS of these Contract Documents). Should the work fail to be completed within the time herein stated, the Contractor shall pay to the Owner, as fixed and agreed liquidated damages, and not as a penalty, the sum, for each day of delay until the work is completed and accepted, as stipulated in the SPECIAL CONDITIONS of these Contract Documents. It is understood that additional time for the completion of the project is to be allowed only for delays as stipulated in the GENERAL CONDITIONS of these Contract Documents.

Bidder acknowledges receipt of the following addendum (addenda):

_____ Dated _____
_____ Dated _____

The undersigned Bidder agrees that this bid shall be good and shall not be withdrawn for a period of sixty (60) calendar days after the opening thereof. If written notice of the acceptance of this Proposal is mailed, telegraphed, or delivered to the undersigned within sixty (60) days after the opening thereof, or at any time thereafter before this Proposal is withdrawn, the undersigned agrees to execute and deliver a Contract in the prescribed form, and furnish the required Performance and Payment Bond, within ten (10) days after the Contract is presented to him for signature.

It is understood by the undersigned Bidder that the Owner reserves the right to reject any or all bids.

Accompanying this Proposal as bid security is certified check/bid bond (Strike One) in the amount of _____ Dollars (\$ _____), being not less than five percent (5%) of the total of the bid. If the undersigned Bidder is the successful Bidder, but fails or refuses to execute the contract and furnish the required bond within the prescribed ten (10) days of the notification of award, then this bid security is to become the property of the Owner as liquidated damages for the delay and additional expense to the Owner caused by such failure or refusal.

Heather Bell
(Witness) Heather Bell
324 CR 407
Jonesboro, AR 72404
(Address)

Turman Construction, Inc.
(Name of Bidder)
By Sherry Turman
Sherry Turman, President
(Print Name and Title)

6555 Hwy. 1 South
Jonesboro, AR 72404
(Office Address of Bidder)

NOTES: Sign in ink. Do not detach.
Items must be bid upon as specified in the Unit Price Schedule.

IV. UNIT PRICE SCHEDULE

<u>Item No</u>	<u>Description</u>	<u>Unit</u>	<u>Quantity</u>	<u>Unit Price</u>	<u>Total Cost</u>
1	Install 12" SDR-35 Sewer Pipe	LF	3,566	\$ <u>34.25</u>	\$ <u>122,135.50</u>
2	Install 20" x 1/4" Steel Casing Dry Auger Bore (Casing Spacers Required per Manuf. Specifications)	LF	268	\$ <u>186.56</u>	\$ <u>49,998.08</u>
3	Install 48" Pre-Cast Manholes	Each	15	\$ <u>1753.00</u>	\$ <u>26,295.00</u>
4	Install 6" Stubouts - 10' Length	Each	7	\$ <u>310.00</u>	\$ <u>2,170.00</u>
5	Clearing and Removing Soil	LS	1	\$ <u>2,500.00</u>	\$ <u>2,500.00</u>
6	Testing - Air, Mandrel, Vacuum	LS	1	\$ <u>3,000.00</u>	\$ <u>3,000.00</u>
7	Dress-up after Ample Settling	LS	1	\$ <u>4,000.00</u>	\$ <u>4,000.00</u>
8	Project Sign	LS	1	\$ <u>500.00</u>	\$ <u>500.00</u>
9	Trench and Excavation Safety	LS	1	\$ <u>3,000.00</u>	\$ <u>3,000.00</u>
TOTAL BASE BID					\$ <u>213,598.58</u>

WRITTEN IN WORDS:

Two hundred thirteen thousand five hundred ninety-eight dollars and fifty-eight cents.

Note: Contractor shall be responsible for all clean-up and repair of any trench settlement that should occur within the one-year Maintenance period for this project.

CERTIFICATION REGARDING LOBBYING

(This Certification is required pursuant to 31 U.S.C. 1352)

Certification for Contracts, Grants, Loans, and Cooperative Agreements

The undersigned certifies, to the best of his or her knowledge and belief, that:

(1) No Federal appropriated funds have been paid or will be paid, by or on behalf of the undersigned, to any person for influencing or attempting to influence an officer or employee of any agency, a Member of Congress, an officer or employee of Congress, or an employee of a Member of Congress in connection with the awarding of any Federal contract, the making of any Federal grant, the making of any Federal loan, the entering into of any cooperative agreement, and the extension, continuation, renewal, amendment, or modification of any Federal contract, grant, loan, or cooperative agreement.

(2) If any funds other than Federal appropriated funds have been paid or will be paid to any person for influencing or attempting to influence an officer or employee of any agency, a Member of Congress, an officer or employee of Congress, or an employee of a Member of Congress in connection with this Federal contract, grant, loan, or cooperative agreement, the undersigned shall complete and submit Standard Form LLL, "Disclosure of Lobbying Activities," in accordance with its instructions.

(3) The undersigned shall require that the language of this certification be included in the award documents for all subawards at all tiers (including subcontracts, subgrants, and contracts under grants, loans, and cooperative agreements) and that all subrecipients shall certify and disclose accordingly.

This certification is a material representation of fact upon which reliance was placed when this transaction was made or entered into. Submission of this certification is a prerequisite for making or entering into this transaction imposed by Section 1352, Title 31, U.S. Code. Any person who fails to file the required certification shall be subject to a civil penalty of not less than \$11,000 and not more than \$110,000 for each such failure.

Please check appropriate box:

No nonfederal funds have been used or are planned to be used for lobbying in connection with this application/award/contract.

or

Attached is Standard Form LLL, "Disclosure of Lobbying Activities," which describes the use (past or planned) of nonfederal funds for lobbying in connection with this application/award/contract.

Executed this 23rd day of September, 20 14

by Sherry Thurman President
(Type or Print Name) (Title of Executing Official)

Sherry Thurman Thurman Construction, Inc.
(Signature of Executing Official) (Name of organization/applicant)

CONTRACT CLAUSE
NEW RESTRICTIONS ON LOBBYING

This contract, subcontract, or subgrant is subject to Section 319 of Public Law 101-121, which added section 1352, regarding lobbying restrictions, to Chapter 13 of Title 31 of the United States Code. The new section is explained in the common rule, 15 CFR Part 28 (55 FR 6736-6748, 2/26/90). Each bidder/applicant/recipient of this contract subcontract, or subgrant and subrecipients are generally prohibited from using Federal funds for lobbying the Executive or Legislative Branches of the Federal Government in connection with this Award.

Contract Clause Threshold

This Contract Clause regarding lobbying must be included in each application for a subgrant and in each bid for a contract or subcontract exceeding \$100,000 of Federal funds at any tier under the Federal Award.

Certification and Disclosure

Each applicant/recipient of a subgrant and each bidder/applicant/ recipient of a contract or subcontract exceeding \$100,000 of Federal funds at any tier under the Federal Award must file a "Certification Regarding Lobbying" and, if applicable, Standard Form LLL, "Disclosure of Lobbying Activities," regarding the use of any nonfederal funds for lobbying. Certifications shall be retained by the next higher tier. All disclosure forms, however, shall be forwarded from tier to tier until received by the Recipient of the Federal Award (grant), who shall forward all disclosure forms to the Federal agency.

Continuing Disclosure Requirement

Each subgrantee, contractor, or subcontractor that is subject to the Certification and Disclosure provision of this Contract Clause is required to file a disclosure form at the end of each calendar quarter in which there occurs any event that requires disclosure or that materially affects the accuracy of the information contained in any disclosure form previously filed by such person. Disclosure forms shall be forwarded from tier to tier until received by the Recipient of the Federal Award (grant) who shall forward all disclosure forms to the Federal agency.

Indian Tribes, Tribal Organizations, or Other Indian Organizations

Indian tribes, tribal organizations, or any other Indian organizations, including the Alaskan Native organizations, are excluded from the above lobbying restrictions and reporting requirements, but only with respect to expenditures that are by such tribes or organizations for lobbying activities permitted by other Federal law. An Indian tribe or organization that is seeking an exclusion from Certification and Disclosure requirements must provide (preferably in an attorney's opinion) EDA with the citation of the provision or provisions of Federal law upon which it relies to conduct lobbying activities that would otherwise be subject to the prohibitions in and to the Certification and Disclosure requirements of Section 319 of Public Law No. 101-121. Note, also, that a non-Indian subgrantee, contractor, or subcontractor under an award (grant) to an Indian tribe, for example, is subject to the restrictions and reporting requirements.

**VI . NOTICE OF REQUIREMENTS FOR AFFIRMATIVE ACTION
TO ENSURE EQUAL EMPLOYMENT OPPORTUNITY
(EXECUTIVE ORDER 11246 AND 41 CFR PART 60-4)**

The following Notice shall be included in, and shall be a part of all solicitations for offers and bids on all Federal and federally assisted construction contracts or subcontracts in excess of \$10,000.

The Offeror's or Bidder's attention is called to the "Equal Opportunity Clause" and the "Standard Federal Equal Employment Opportunity Construction Contract Specifications" set forth herein.

The goals and timetables for minority and female participation, expressed in percentage terms for the Contractor's aggregate workforce in each trade on all construction work in the covered area, are as follows:

Timetables	Goals for minority participation for each trade	Goals for female participation for each trade
	<div style="border: 1px solid black; width: 40px; height: 20px; display: inline-block;"></div> %	6.9%

These goals are applicable to all the Contractor's construction work (whether or not it is Federal or federally assisted) performed in the covered area. If the contractor performs construction work in a geographical area located outside of the covered area, it shall apply the goals established for such geographical area where the work is actually performed. With regard to this second area, the contractor also is subject to the goals for both its federally involved and non federally involved construction.

The Contractor's compliance with the Executive Order and the regulations in 41 CFR Part 60-4 shall be based on its implementation of the Equal Opportunity Clause, specific affirmative action obligations required by the specifications set forth in 41 CFR 60-4.3(a), and its efforts to meet the goals. The hours of minority and female employment and training must be substantially uniform throughout the length of the contract, and in each trade and the contractor shall make a good faith effort to employ minorities and women evenly on each of its projects. The transfer of minority or female employees or trainees from Contractor to Contractor or from project to project for the sole purpose of meeting the Contractor's goals shall be a violation of the contract, the Executive Order, and the regulations in 41 CFR Part 60-4. Compliance with the goals will be measured against the total work hours performed.

The Contractor shall provide written notification to the Director of the Office of Federal Contract Compliance Programs within 10 working days of award of any construction subcontract in excess of \$10,000 at any tier for construction work under the contract resulting from this solicitation. The notification shall list the name, address and telephone number of the subcontractor; employer identification number of the subcontractor; estimated dollar amount of the subcontract; estimated starting and completion dates of the subcontract; and the geographical area in which the subcontract is to be performed. As used in this Notice, and in the contract resulting from this solicitation, the "covered area" is:

State of	Arkansas
County of	Craighead
City of	Jonesboro

THE AMERICAN INSTITUTE OF ARCHITECTS



AIA Document A310

Bid Bond

KNOW ALL MEN BY THESE PRESENTS, that we **Turman Construction, Inc., 6555 Highway 1 South, Jonesboro, AR 72404**

as Principal, hereinafter called the Principal, and **SureTec Insurance Company**

a corporation duly organized under the laws of the State of **Texas**

as Surety, hereinafter called the Surety, are held and firmly bound unto **City of Jonesboro, 515 W. Washington Ave., Jonesboro, AR 72401**

as Obligee, hereinafter called the Obligee, in the sum of **Five Percent of amount bid**

Dollars(\$ **5%**),

for the payment of which sum well and truly to be made, the said Principal and the said Surety, bind ourselves, our heirs, executors, administrators, successors and assigns, jointly and severally, firmly by these presents.

WHEREAS, the Principal has submitted a bid for **Dalton Farmer Drive Sanitary Sewer Extension Project, Jonesboro, Arkansas.**

NOW, THEREFORE, if the Obligee shall accept the bid of the Principal and the Principal shall enter into a Contract with the Obligee in accordance with the terms of such bid, and give such bond or bonds as may be specified in the bidding or Contract Documents with good and sufficient surety for the faithful performance of such Contract and for the prompt payment of labor and material furnished in the prosecution thereof, or in the event of the failure of the Principal to enter such Contract and give such bond or bonds, if the Principal shall pay to the Obligee the difference not to exceed the penalty hereof between the amount specified in said bid and such larger amount for which the Obligee may in good faith contract with another party to perform the Work covered by said bid, then this obligation shall be null and void, otherwise to remain in full force and effect.

Signed and sealed this **24th** day of **September**, **2014.**

Heather B. Bell

(Witness)

{ **Turman Construction, Inc.**
[Signature] (Principal) (Seal)
President

(Title)

Jan Melton

(Witness)

{ **SureTec Insurance Company**

(Surety) (Seal)
Michael A. McDaniel

(Title)

Jan Melton

Michael A. McDaniel, Attorney-in-Fact

SureTec Insurance Company

LIMITED POWER OF ATTORNEY

Know All Men by These Presents, That SURETEC INSURANCE COMPANY (the "Company"), a corporation duly organized and existing under the laws of the State of Texas, and having its principal office in Houston, Harris County, Texas, does by these presents make, constitute and appoint

Michael A. McDaniel, Richard H. Whitley, James S. Brown

its true and lawful Attorney-in-fact, with full power and authority hereby conferred in its name, place and stead, to execute, acknowledge and deliver any and all bonds, recognizances, undertakings or other instruments or contracts of suretyship to include waivers to the conditions of contracts and consents of surety for:

Five Million and 00/100 Dollars (\$5,000,000.00)

and to bind the Company thereby as fully and to the same extent as if such bond were signed by the President, sealed with the corporate seal of the Company and duly attested by its Secretary, hereby ratifying and confirming all that the said Attorney-in-Fact may do in the premises. Said appointment shall continue in force until 12/31/16 and is made under and by authority of the following resolutions of the Board of Directors of the SureTec Insurance Company:

Be it Resolved, that the President, any Vice-President, any Assistant Vice-President, any Secretary or any Assistant Secretary shall be and is hereby vested with full power and authority to appoint any one or more suitable persons as Attorney(s)-in-Fact to represent and act for and on behalf of the Company subject to the following provisions:

Attorney-in-Fact may be given full power and authority for and in the name of and of behalf of the Company, to execute, acknowledge and deliver, any and all bonds, recognizances, contracts, agreements or indemnity and other conditional or obligatory undertakings and any and all notices and documents canceling or terminating the Company's liability thereunder, and any such instruments so executed by any such Attorney-in-Fact shall be binding upon the Company as if signed by the President and sealed and effected by the Corporate Secretary.

Be it Resolved, that the signature of any authorized officer and seal of the Company heretofore or hereafter affixed to any power of attorney or any certificate relating thereto by facsimile, and any power of attorney or certificate bearing facsimile signature or facsimile seal shall be valid and binding upon the Company with respect to any bond or undertaking to which it is attached. (Adopted at a meeting held on 20th of April, 1999.)

In Witness Whereof, SURETEC INSURANCE COMPANY has caused these presents to be signed by its President, and its corporate seal to be hereto affixed this 21st day of March, A.D. 2013.

SURETEC INSURANCE COMPANY

By: [Signature]
John Knox Jr., President



State of Texas ss:
County of Harris

On this 21st day of March, A.D. 2013 before me personally came John Knox Jr., to me known, who, being by me duly sworn, did depose and say, that he resides in Houston, Texas, that he is President of SURETEC INSURANCE COMPANY, the company described in and which executed the above instrument; that he knows the seal of said Company; that the seal affixed to said instrument is such corporate seal; that it was so affixed by order of the Board of Directors of said Company; and that he signed his name thereto by like order.

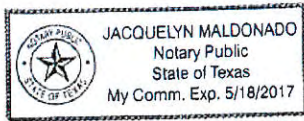

[Signature]
Jacquelyn Maldonado, Notary Public
My commission expires May 18, 2017

I, M. Brent Beaty, Assistant Secretary of SURETEC INSURANCE COMPANY, do hereby certify that the above and foregoing is a true and correct copy of a Power of Attorney, executed by said Company, which is still in full force and effect; and furthermore, the resolutions of the Board of Directors, set out in the Power of Attorney are in full force and effect.

Given under my hand and the seal of said Company at Houston, Texas this 24th day of September 2014, A.D.

[Signature]
M. Brent Beaty, Assistant Secretary

Any instrument issued in excess of the penalty stated above is totally void and without any validity.
For verification of the authority of this power you may call (713) 812-0800 any business day between 8:00 am and 5:00 pm CST.



CERTIFICATE OF LIABILITY INSURANCE

DATE (MM/DD/YYYY)
9/23/2014

THIS CERTIFICATE IS ISSUED AS A MATTER OF INFORMATION ONLY AND CONFERS NO RIGHTS UPON THE CERTIFICATE HOLDER. THIS CERTIFICATE DOES NOT AFFIRMATIVELY OR NEGATIVELY AMEND, EXTEND OR ALTER THE COVERAGE AFFORDED BY THE POLICIES BELOW. THIS CERTIFICATE OF INSURANCE DOES NOT CONSTITUTE A CONTRACT BETWEEN THE ISSUING INSURER(S), AUTHORIZED REPRESENTATIVE OR PRODUCER, AND THE CERTIFICATE HOLDER.

IMPORTANT: If the certificate holder is an ADDITIONAL INSURED, the policy(ies) must be endorsed. If SUBROGATION IS WAIVED, subject to the terms and conditions of the policy, certain policies may require an endorsement. A statement on this certificate does not confer rights to the certificate holder in lieu of such endorsement(s).

PRODUCER East Arkansas Insurance Agency Inc. P.O. Box 1553 Jonesboro, AR 72403 247779	CONTACT NAME: PHONE (A/C No Ext): 870-935-5983 FAX (A/C No): 870-935-2644 E-MAIL ADDRESS: eastarins@rittermail.com
	INSURER(S) AFFORDING COVERAGE INSURER A: Union Standard Insurance Co NAIC# 020 INSURER B: First Comp INSURER C: INSURER D: INSURER E: INSURER F:
INSURED Turman Construction Co. 6555 Hwy 1 South Jonesboro, AR 724040000	

COVERAGES CERTIFICATE NUMBER: REVISION NUMBER.

THIS IS TO CERTIFY THAT THE POLICIES OF INSURANCE LISTED BELOW HAVE BEEN ISSUED TO THE INSURED NAMED ABOVE FOR THE POLICY PERIOD INDICATED. NOTWITHSTANDING ANY REQUIREMENT, TERM OR CONDITION OF ANY CONTRACT OR OTHER DOCUMENT WITH RESPECT TO WHICH THIS CERTIFICATE MAY BE ISSUED OR MAY PERTAIN, THE INSURANCE AFFORDED BY THE POLICIES DESCRIBED HEREIN IS SUBJECT TO ALL THE TERMS, EXCLUSIONS AND CONDITIONS OF SUCH POLICIES. LIMITS SHOWN MAY HAVE BEEN REDUCED BY PAID CLAIMS.

INBR LTR	TYPE OF INSURANCE	ADDL INSN	SUBR WVD	POLICY NUMBER	POLICY EFF (MM/DD/YYYY)	POLICY EXP (MM/DD/YYYY)	LIMITS
A	GENERAL LIABILITY <input checked="" type="checkbox"/> COMMERCIAL GENERAL LIABILITY CLAIMS-MADE <input type="checkbox"/> OCCUR <input checked="" type="checkbox"/>			CNA4352967-13	02/28/14	02/28/15	EACH OCCURRENCE \$ 1,000,000 DAMAGE TO RENTED PREMISES (Ea occurrence) \$ 100,000 MED EXP (Any one person) \$ 5,000 PERSONAL & ADV INJURY \$ 1,000,000 GENERAL AGGREGATE \$ 2,000,000 PRODUCTS - COMP/OP AGG \$ 2,000,000
	GEN'L AGGREGATE LIMIT APPLIES PER POLICY <input type="checkbox"/> PROJECT <input type="checkbox"/> LOC <input type="checkbox"/>						
A	AUTOMOBILE LIABILITY <input checked="" type="checkbox"/> ANY AUTO ALL OWNED AUTOS <input type="checkbox"/> SCHEDULED AUTOS HIRED AUTOS <input type="checkbox"/> NON-OWNED AUTOS			CNA4352967-13	02/28/2014	02/28/2015	COMBINED SINGLE LIMIT (Ea accident) \$ 1,000,000 BODILY INJURY (Per person) \$ BODILY INJURY (Per accident) \$ PROPERTY DAMAGE (Per accident) \$
	UMBRELLA LIAB <input type="checkbox"/> OCCUR EXCESS LIAB <input type="checkbox"/> CLAIMS-MADE ULD <input type="checkbox"/> RETENTION \$						
B	WORKERS COMPENSATION AND EMPLOYERS LIABILITY ANY PROPRIETOR/PARTNER/EXECUTIVE OFFICER/MEMBER EXCLUDED? (Mandatory in NH) If yes, describe under DESCRIPTION OF OPERATIONS below	Y/N <input type="checkbox"/>	N/A	WC0034262-07	11/12/13	11/12/14	<input checked="" type="checkbox"/> WC STATUTORY LIMITS <input type="checkbox"/> OTHER EL EACH ACCIDENT \$ 500,000 EL DISEASE - EA EMPLOYEE \$ 500,000 EL DISEASE - POLICY LIMIT \$ 500,000

DESCRIPTION OF OPERATIONS / LOCATIONS / VEHICLES (Attach ACORD 101 Additional Remarks Schedule, if more space is required)

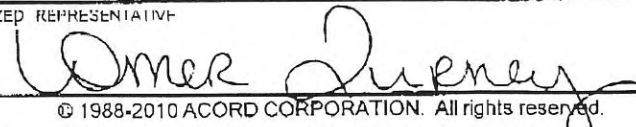
CERTIFICATE HOLDER City of Jonesboro 515 West Washington Jonesboro, AR 72401	CANCELLATION SHOULD ANY OF THE ABOVE DESCRIBED POLICIES BE CANCELLED BEFORE THE EXPIRATION DATE THEREOF, NOTICE WILL BE DELIVERED IN ACCORDANCE WITH THE POLICY PROVISIONS AUTHORIZED REPRESENTATIVE 
------------------------------------------------------------------------------------------------------------	----------------------------------------------------------------------------------------------------------------------------------------------------------------------------------------------------------------------------------------------------------------------------------------------------

IX. STATEMENT OF BIDDER'S QUALIFICATIONS

All questions must be answered and the data given must be clear and comprehensive. This statement must be notarized. If necessary, questions may be answered on separate attached sheets. The Bidder may submit any additional information he desires.

1. Name of Bidder. Turman Construction, Inc.
2. Permanent main office address. 6555 Hwy. 1 South, Jonesboro, AR 72404
3. When organized. 1986
4. If a corporation, where incorporated. Arkansas
5. How many years have been engaged in the contracting business under your present firm or trade name? 1999
6. Contracts on hand: (Schedule these, showing amount of each contract and the appropriate anticipated dates of completion). Mark Morris - Merrell Estates, Phase IV
7. General character of work performed by your company. Sewer/Water main install
8. Have you ever failed to complete any work awarded to you? No
9. Have you ever defaulted on a Contract? No
If so, where and why?
10. Have you ever been fined or had your license suspended by a Contractor's Licensing Board? No
If so, where and why?
11. List the more important projects recently completed by your company, stating the approximate cost for each, and the month and year completed. Angela Lee Drive, Firestation #5 water lines, Merrell Estates
12. List your major equipment available for this Contract. Truckhoe, Bobcat, Excavator, mini-excavator + Dzer
13. Experience in construction work similar in importance to this project. Multiple jobs for CW+K, local developers
14. Background and experience of the principal members of your organization, including the officers.
15. Credit available: \$ 3,000,000.⁰⁰
16. Give Bank reference: Heritage Bank
Joe Verser

X. NOTICE OF AWARD

To: _____

PROJECT Description: _____

The OWNER has considered the BID submitted by you for the above described WORK in response to its Advertisement for Bids dated _____, 20_____, and information for Bidders.

You are hereby notified that your BID has been accepted for items in the amount of \$ _____.

You are required by the Information for Bidders to execute the Agreement and furnish the required CONTRACTOR'S Performance BOND, Payment BOND and certificates of insurance within ten (10) calendar days from the date of this Notice to you.

If you fail to execute said Agreement and to furnish said BONDS, within ten (10) days from the date of this Notice, said OWNER will be entitled to consider all your rights arising out of the OWNER'S acceptance of your BID as abandoned and as a forfeiture of your BID BOND. The OWNER will be entitled to such rights as may be granted by law.

You are required to return an acknowledged copy of this NOTICE OF AWARD to the OWNER.

Dated this _____ day of _____, 20_____.

Owner

By _____

Title _____

ACCEPTANCE OF NOTICE

Receipt of the above NOTICE OF AWARD is hereby acknowledged

by _____,

this the _____ day of _____, 20_____.

By _____

Title _____

XI . NOTICE TO PROCEED

Date: _____

To: _____

Project: _____

You are hereby notified to commence WORK in accordance with the Agreement dated _____, 20 _____, on or before _____, 20 _____, and you are to complete the WORK within _____ consecutive calendar days thereafter. The date of completion of all WORK is therefore _____, 20 _____.

Owner

By _____

Title _____

ACCEPTANCE OF NOTICE

Receipt of the above NOTICE TO PROCEED is hereby acknowledged

by _____

this the _____ day of _____, 20 _____

By _____

Title _____

XII. CHANGE ORDER

Order No. _____

Date: _____

Agreement Date: _____

NAME OF PROJECT: _____

OWNER: _____

CONTRACTOR: _____

The following changes are hereby made to the CONTRACT DOCUMENTS:

Justification:

Change to CONTRACT PRICE: \$ _____.

Original CONTRACT PRICE: \$ _____.

Current CONTRACT PRICE adjusted by previous CHANGE ORDER: \$ _____.

The CONTRACT PRICE due to this CHANGE ORDER will be (increased) (decreased) by: \$ _____.

The new CONTRACT PRICE including this CHANGE ORDER will be: \$ _____.

Change to CONTRACT TIME:

The CONTRACT TIME will be (increased) (decreased) by _____ calendar days.

The date for completion of all work will be _____ (Date).

Approvals Required:

To be effective this Order must be approved by the Federal agency if it changes the scope or objective of the PROJECT, or as may otherwise be required by the SUPPLEMENTAL GENERAL CONDITIONS.

Requested by: _____

Recommended by: _____

Ordered by: _____

Accepted by: _____

Federal Agency Approval (where applicable) _____

VII. CONTRACT

THIS AGREEMENT made this _____ day of _____, 20____, by and

between Turman Construction, Inc.

(a Corporation organized and existing under the laws of the State of Arkansas)

Hereinafter called the "Contractor" and the City of Jonesboro, Arkansas, hereinafter called the "Owner".

WITNESSETH:

That the Contractor and the Owner for the consideration stated herein mutually agree as follows:

ARTICLE 1. Statement of Work. The Contractor shall furnish all supervision, technical personnel, labor, materials, machinery, tools, equipment, incidentals and services, including utility and transportation services and perform and complete all work required for the Dalton-Farmer Sanitary Sewer Extension Project, in strict accordance with the Contract Documents, including all Addenda thereto

_____ dated _____

_____ dated _____

_____ dated _____

as prepared by the Engineer.

ARTICLE 2. The Contract Price. The Owner will pay the Contractor, because of his performance of the Contract, for the total quantities of work performed at the lump sum and unit prices stipulated in the Proposal, subject to additions and deductions as provided in the Section entitled "CHANGES IN THE WORK" under the GENERAL CONDITIONS.

ARTICLE 3. Contract Time. The Contractor agrees to begin work within ten (10) calendar days after issuance by the Owner of a "Work Order" or "Notice to Proceed" and to complete the work within ninety (90) calendar days thereafter (except as modified in the GENERAL CONDITIONS of these Contract Documents). If the Contractor shall fail to complete the work within the time specified, he and his Surety shall be liable for payment to the Owner, as liquidated damages ascertained and agreed, and not in the nature of a penalty, the amount specified in the SPECIAL CONDITIONS of these Contract Documents for each day of delay. To the extent sufficient in amount, liquidated damages

shall be deducted from the payments to be made under this Contract.

ARTICLE 4. Contract. The executed Contract Documents shall consist of the following:

- a. This Agreement (Contract)
- b. Addenda
- c. Advertisement for Bids
- d. Instructions to Bidders
- e. Proposal
- f. General Conditions
- g. Supplemental General Conditions
- h. Special Conditions
- i. Technical Specifications including
Special Provisions
- j. Drawings (Plans)
- k. Performance-Payment Bond

This Contract, together with other Documents enumerated in this Article 4, which said other Documents are as fully a part of the Contract as if hereto attached or herein repeated, form the Contract between the parties hereto. In the event that any provisions in any component part of this Contract conflicts with any provision of any other component part, the conflict shall be resolved by the Engineer whose decision shall be final.

ARTICLE 5. Surety. The Surety on the Performance-Payment Bond shall be a surety company of financial resources satisfactory to the Owner, authorized to do business in the State of Arkansas, and shall comply with applicable Arkansas laws.

IN WITNESS WHEREOF, the parties hereto have caused this CONTRACT to be executed in four (4) counterparts, each of which shall be considered an original on the day and year first above written.

ATTEST:

(Contractor)

_____ By _____

_____ Title _____

(Street)

(City)

City of Jonesboro
(Owner)

_____ By _____

XIV. ARKANSAS PERFORMANCE-PAYMENT BOND

KNOW ALL MEN BY THESE PRESENTS:

THAT WE, _____

as Principal, hereinafter called Principal, and _____

of _____ State of _____,
as Surety, hereinafter called the Surety, are held and firmly bound unto the City of Jonesboro as Obligee, hereinafter called Owner, in the amount _____ Dollars (\$ _____) in lawful money of the United States of America, for the payment of which sum well and truly to be made, we bind ourselves, our heirs, executors, administrators, and successors, jointly, severally, and firmly by these presents.

THE CONDITION OF THIS OBLIGATION IS SUCH THAT:

WHEREAS, The Principal entered into a Contract with the Owner by written Agreement dated the _____ day of _____, 20____, a copy of which is attached hereto and made a part hereof, hereinafter referred to as the Contract, for the Dalton-Farmer Drive Sanitary Sewer Extension Project.

NOW THEREFORE, if the Principal shall well and truly perform and complete in good, sufficient, and workmanlike manner all of the work required by said Contract and within the time called for thereby to the satisfaction of the Owner, and shall pay all persons for labor, materials, equipment, and supplies furnished by said Principal in accordance with said Contract (failing which such persons shall have a direct right to action against the Principal and Surety under this obligation, but subject to the Owner's priority) and shall hold and save harmless the Owner from any and all claims, loss, and expense of every kind and nature arising because of or resulting from the Principal's operation under said Contract, except payments to the Principal rightly due the Principal for work under said Contract, then this obligation shall be null and void; otherwise to remain in full force and effect.

Any alterations which may be made in the terms of the Contract, or in the work to be done under it, or the giving by the Owner of an extension of time for the performance of the Contract, or any other forbearance on the part either of the Owner or Principal to the other shall not release in any way the Principal and Surety, or either of them, their heirs, personal representatives, successors, or assigns from their liability hereunder, notice to the Surety of any alteration, extension, or forbearance hereby being waived.

In no event shall the aggregate liability of the Surety exceed the sum set herein.

No suit, action, or proceeding shall be brought on this bond outside the State of Arkansas. No suit, action, or proceeding shall be brought on this bond, except by the Owner, after six (6) months from the date on which final payment to the Contractor falls due. No suit, action, or proceeding shall be brought by the Owner after two (2) years from the date on which final payment to the Contractor falls due.

This bond is executed pursuant to the terms of Arkansas Code Ann. §§ 18-44-501 et. seq.

Executed on this _____ day of _____, 20____.

(Principal)

By _____

Title _____

SEAL

(Surety)

By _____
(Attorney-in-Fact)

NOTES:

1. This bond form is mandatory. No other forms will be acceptable.
2. The date of the Bond must not be prior to the date of the Contract.
3. Any surety executing this Bond must appear on the U.S. Treasury Department's most current list (Circular 570, as amended) and be authorized to transact business in the State of Arkansas.
4. Attach Power of Attorney.

XV. GENERAL CONDITIONS

TABLE OF CONTENTS

GC.1	DEFINITIONS
GC.2	SUPERINTENDENCE BY CONTRACTORS
GC.3	CONTRACTOR'S EMPLOYEES
GC.4	SAFETY OF CONTRACTOR'S EMPLOYEES
GC.5	SUBCONTRACTS
GC.6	OTHER CONTRACTS
GC.7	CONTRACTORS INSURANCE
GC.8	OWNER'S AND ENGINEER'S PROTECTIVE LIABILITY INSURANCE
GC.9	FITTING AND COORDINATION OF THE WORK
GC.10	MUTUAL RESPONSIBILITY OF CONTRACTORS
GC.11	PAYMENT TO CONTRACTOR
GC.12	USE OF COMPLETED PORTIONS
GC.13	CHANGES IN THE WORK
GC.14	CLAIMS FOR EXTRA COST
GC.15	OWNER'S RIGHT TO TERMINATE CONTRACT
GC.16	SUSPENSION OF WORK
GC.17	DELAYS; EXTENSION OF TIME; LIQUIDATED DAMAGES
GC.18	DISPUTES
GC.19	ASSIGNMENT OR NOVATION
GC.20	TECHNICAL SPECIFICATIONS AND DRAWINGS
GC.21	SHOP DRAWINGS
GC.22	REQUESTS FOR SUPPLEMENTARY INFORMATION
GC.23	REFERENCE TO MANUFACTURER OR TRADE NAME-"OR EQUAL CLAUSE"
GC.24	SAMPLES, CERTIFICATES AND TESTS
GC.25	PERMITS AND CODES
GC.26	CARE OF THE WORK
GC.27	QUALITY OF WORK AND PROPERTY
GC.28	ACCIDENT PREVENTION
GC.29	SANITARY FACILITIES
GC.30	USE OF PREMISES
GC.31	REMOVAL OF DEBRIS, CLEANING, ETC.
GC.32	RETURN OF OWNER'S MATERIALS, EQUIPMENT OR PROPERTY
GC.33	OBSERVATION OF THE WORK
GC.34	REVIEW BY LOCAL PUBLIC AGENCY OR OWNER
GC.35	PROHIBITED INTERESTS
GC.36	FINAL INSPECTION
GC.37	PATENTS
GC.38	WARRANTY OF TITLE
GC.39	GENERAL GUARANTY

GC.1 DEFINITIONS

Wherever used in any of the Contract Documents, the following meanings shall be given to the terms herein defined:

(1) The term "Addendum" means any change, revision, or clarification of the Contract Documents which has been duly issued by the Local Public Agency, or the Engineer, to prospective Bidders prior to the time of receiving bids.

(2) The term "Award" means the acceptance by the owner of the successful bidder's proposal.

(3) The term "Bidder" means any individual, partnership, firm, or corporation, acting directly or through a duly authorized representative, who submits a proposal for the work contemplated.

(4) The term "Calendar Day" means every day shown on the calendar.

(5) The term "Change Order" means a written order to the contractor covering changes in the plans, specifications, or proposal quantities and establishing the basis of payment and contract time adjustment, if any, for the scope of work affected by the change. The work covered by the change order shall be within the scope of the contract.

(6) The term "Contract" means the Contract executed by the Local Public Agency and the Contractor of which these GENERAL CONDITIONS form a part.

(7) The term "Contract Documents" means and shall include the following: Executed Contract, Addenda (if any), Advertisement For Bids, Instructions to Bidders, Proposal, Performance-Payment Bond, General Conditions, Supplemental General Conditions, Special Conditions, Supplemental Special Conditions, Technical Specifications, and Drawings.

(8) The term "Contractor" means the person, firm, or corporation entering into the Contract with the Local Public Agency to construct and install the improvements embraced in this project.

(9) The term "Engineer" means the City of Jonesboro Engineering Department, serving the Local Public Agency with engineering services, its successor, or any other person or persons employed by said Local Public Agency to furnish engineering services in connection with the construction embraced in the Contract.

(10) The term "Local Government" means the City of Jonesboro, Arkansas, within which the Project is situated.

(11) The term "Local Public Agency" or "Owner" means the City of Jonesboro, which is authorized to undertake this Contract.

(12) The term "Plans" or "Drawings" means the official drawings or exact reproductions which show the location, character, and details of the work contemplated, and which are to be considered part of the contract, supplementary to the specifications.

(13) The term "Proposal" means the written offer of the Bidder (when submitted on the approved proposal form) to perform the contemplated work and furnish the necessary materials in accordance with the provisions of the Plans and Specifications.

(14) The term "Specifications" means a part of the contract containing the written directions and requirements for completing the contract work. Standards for specifying materials, or testing, which are cited in the specifications by reference shall have the same force and effect as if included in the contract physically.

(15) The term "Subcontractors" shall mean the individual, partnership or corporation entering into an agreement with the Contractor to perform any portion of the work covered by the Plans and Specifications.

(16) The term "Surety" shall mean any person, firm, or corporation that has executed, as Surety, the Contractor's Performance Bond securing the performance of the Contract.

(17) The term "Technical Specifications" means that part of the Contract documents which describes, outlines and stipulates the quality of the materials to be furnished; the quality of workmanship required; and the controlling requirements to be met in carrying out the construction work to be performed under this Contract. This also includes Special Provisions.

(18) The term "Work" shall mean the furnishing of all necessary labor, tools, equipment, appliances, supplies, and material other than materials furnished by the Owner as specified to complete the construction covered by the Plans and Specifications.

GC.2 SUPERINTENDENCE BY CONTRACTORS

Except where the Contractor is an individual and gives his personal superintendence to the work, the Contractor shall provide a competent superintendent, satisfactory to the Local Public Agency and the Engineer, on the work at all times during working hours with full authority to supervise and direct the work and who shall be the Contractor's agent responsible for the faithful discharge of the Contractor's obligations under the Contract.

The Owner shall have the authority to require the Contractor to remove from the work any incompetent or insubordinate superintendent.

GC.3 CONTRACTOR'S EMPLOYEES

The Contractor shall employ only competent skillful workers and shall at all times enforce strict discipline and good order among the employees.

The Contractor shall neither permit nor suffer the introduction or use of alcoholic beverages or controlled substances upon or about the work embraced in this Contract.

The Owner may require the Contractor to dismiss from the work such employee or employees as the Owner or the Engineer may deem incompetent, or careless, or insubordinate.

GC.4 SAFETY OF CONTRACTOR'S EMPLOYEES

The Contractor shall be responsible for the safety of his employees during the progress of the work as well as the safety, efficiency, and adequacy of his plant, appliances, and methods, and for any damage which may result from their failure or their improper construction, maintenance or operation.

GC.5 SUBCONTRACTS

The Contractor is responsible to the Owner for the acts and omissions of his subcontractors and of persons either directly or indirectly employed by the subcontractors and is aware that nothing contained in the Contract Documents shall create any contractual relation between any subcontractor and the Owner.

GC.6 OTHER CONTRACTS

The Local Public Agency may award, or may have awarded other Contracts for additional work, and the Contractor shall cooperate fully with such other Contractors, by scheduling his own work with that to be performed under other Contracts as may be directed by the Local Public Agency. The Contractor shall not commit or permit any act which will interfere with the performance of work by any other Contractor as scheduled.

GC.7 CONTRACTOR'S INSURANCE

Before any work is commenced, the Contractor shall furnish an approved certificate of insurance addressed to the Owner, showing that he carries the following insurance which shall be maintained throughout the term of the Contract.

(1) Workmen's Compensation

- Statutory Limit

- | | |
|-------------------------------------------------------------|-----------------------------------------------------|
| (2) Employer's Liability for Hazardous Work | - If Needed |
| (3) Public Liability (Bodily Injury)
and Property Damage | - \$1,000,000/occurrence
- \$2,000,000/aggregate |
| (4) Builder's Risk | - Insurable Portion |

The Contractor shall carry or require that there be carried the insurance listed in (1) through (3) above for the protection of all his employees and those of his Subcontractors engaged in work under this Contract, and for the protection of the public.

If the work includes pipelines or other underground structures, the Property Damage Liability shall include explosion, collapse, and underground coverage.

The premiums for all insurance and the bond required herein shall be paid by the Contractor.

It shall be the obligation of the Contractor to complete and deliver to the Owner the structure required by these Contract Documents regardless of any loss, damage to, or destruction of the structure prior to delivery.

GC.8 OWNER'S AND ENGINEER'S PROTECTIVE LIABILITY INSURANCE

The Owner requires the Contractor to name the City of Jonesboro and City Water & Light (CWL) as an additional insured on their Protective Liability insurance, which shall be in force for the entire project period. Limits of liability shall be the following:

- | | |
|----------------------------------------------------------------------------------------------------------------------|-----------------------------------------------------|
| Bodily Injury Liability (Including Death)
and Physical Damage Liability
(Damage to or Destruction of Property) | - \$1,000,000/occurrence
- \$2,000,000/aggregate |
|----------------------------------------------------------------------------------------------------------------------|-----------------------------------------------------|

GC.9 FITTING AND COORDINATION OF THE WORK

The Contractor shall be responsible for the proper fitting of all work and for the coordination of the operations of all trades, Subcontractors, or material men engaged upon this Contract. He shall be prepared to guarantee to each of his Subcontractors the locations and measurements which they may require for the fitting of their work to all surrounding work.

GC.10 MUTUAL RESPONSIBILITY OF CONTRACTORS

If, through acts of neglect or through failure to comply with any applicable Government regulations by the Contractor, any other Contractor or any Subcontractor shall suffer loss or damage on the work, the

Contractor shall settle with such other Contractor or Subcontractor by agreement or arbitration, if such other Contractor or Subcontractor will so settle. If such other Contractor or Subcontractor shall assert any claim against the Local Public Agency on account of any damage alleged to have been so sustained, the Local Public Agency will notify this Contractor, who shall defend at his own expense any suit based upon such claim, and, if any judgments or claims against the Local Public Agency shall be allowed, the Contractor shall pay or satisfy such judgments or claim and pay all costs and expenses in connection therewith.

GC.11 PAYMENT TO CONTRACTOR

Payment will be made to the Contractor once a month. The Engineer will prepare (with the required assistance from the Contractor) the application for partial payment. If the bid contains lump sum prices, the Contractor shall furnish to the Engineer, upon request, a detailed cost breakdown of the several items of work involved in the lump sum prices. The Engineer will use this cost breakdown to determine the amount due the Contractor as progress payment.

The amount of the payment due to the Contractor shall be determined by the total value of work completed to date, deducting five percent (5%) for retainage, adding the value of submitted paid invoices covering construction materials, properly stored on the site, and deducting the amount of all previous payments. The total value of work completed to date shall be based on the estimated quantities of work completed and on the unit and lump sum prices contained in the Proposal. The value of materials properly stored on the site shall be based upon the estimated quantities of such materials and the invoice prices. Copies of paid invoices, covering construction materials for which material payments are made, shall be furnished to the Engineer before such material payments are made.

NOTE: It has been the policy of the Owner to make payments for properly stored materials/equipment based upon invoice price and allow the Contractor to submit paid invoices within 30 days (or the next partial payment period). If paid invoices are not provided within the time allowed, then the materials/equipment so paid for will be removed from the next partial payment.

Monthly or partial payments made by the Owner to the Contractor are monies advanced for the purpose of assisting the Contractor to expedite the work of construction. All material and complete work covered by such monthly or partial payments shall remain the property of the Contractor, and he shall be responsible for the care and protection of all materials and work upon which payments have been made. Such payments shall not constitute a waiver of the right of the Owner to require the fulfillment of all terms of the Contract and the delivery of all improvements embraced in this Contract complete and satisfactory to the Owner in all details.

GC.11.1 Withholding Payments: The Local Public Agency may withhold from any payment otherwise due the Contractor so much as may be necessary to protect the Local Public Agency and if it so elects may also withhold any amounts due from the Contractor to any Subcontractors or material

dealers, for work performed or material furnished by them. The foregoing provisions shall be construed solely for the benefit of the Local Public Agency and will not require the Local Public Agency to determine or adjust any claims or disputes between the Contractor and his Subcontractors or material dealers, or to withhold any monies for their protection unless the Local Public Agency elects to do so. The failure or refusal of the Local Public Agency to withhold any monies from the Contractor shall not impair the obligations of any Surety or Sureties under any bond or bonds furnished under this Contract. Such withholding may also occur as a result of the Contractor's failure or refusal to prosecute the work with such diligence as will insure its completion within the time specified in these Contract Documents, or as modified as provided in these Contract Documents, or if the Contractor fails to comply with any applicable regulations promulgated by the U.S. Government or any other Government agencies.

GC.11.2 Final Payment: After final inspection and acceptance by the Local Public Agency of all work under the Contract, the application for final payment shall be prepared which shall be based upon the carefully measured or computed quantity of each item of work at the applicable unit and lump sum prices stipulated in the Unit Price Schedule. The total number of the final payment due the Contractor under this Contract shall be the amount computed as described above less all previous payments. All prior payments shall be subject to correction in the final payment. Final payment to the Contractor shall be made subject to his furnishing the Local Public Agency with a release in satisfactory form of all claims against the Local Public Agency arising under and by virtue of his Contract, other than such claims, if any, as may be specifically excepted by the Contractor from the operation and the release as provided under the section entitled DISPUTES under GENERAL CONDITIONS.

The Local Public Agency, before paying the final estimate, may require the Contractor to furnish releases or receipts from all Subcontractors having performed any work and all persons having supplied materials, equipment (installed on the Project), and services to the Contractor, if the Local Public Agency deems the same necessary in order to protect its interest. The Local Public Agency, however, may, if it deems such action advisable, make payment in part or in full to the Contractor without requiring the furnishing of such releases or receipts and any payments so made shall not impair the obligations of any Surety or Sureties furnished under this Contract.

Withholding of any amount due the Local Public Agency under the section entitled LIQUIDATED DAMAGES FOR DELAY under SPECIAL CONDITIONS, shall be deducted from the payments due the Contractor.

All equipment warranties and general guarantee and maintenance bond provisions shall become effective for one year upon date of final acceptance of the completed, project by the Local Public Agency.

GC.11.3 Payments Subject to Submission of Certificates: Each payment to the Contractor by the Local Public Agency shall be made subject to submission by the Contractor of all written certifications required of him.

GC.12 USE OF COMPLETED PORTIONS

The Owner shall have the right to use any completed or partially completed portion of the work and such use shall not be considered as an acceptance of any work.

GC.13 CHANGES IN THE WORK

The Local Public Agency may make changes in the scope of the work required to be performed by the Contractor under the Contract or make additions thereto, or omit work therefrom without invalidating the Contract, and without relieving or releasing the Contractor from any of his obligations under the Contract or any guarantee given by him pursuant to the Contract provisions, and without affecting the validity of the Guaranty Bonds, and without relieving or releasing the Surety or Sureties of said bonds. All such work shall be executed under the terms of the original Contract unless it is expressly provided otherwise.

Except for the purpose of affording protection against any emergency endangering life or property, the Contractor shall make no change in the materials used or in the specified manner of constructing and/or installing the improvements, or supply additional labor, services or materials beyond that actually required for the execution of the Contract, unless in pursuance of a written order from the Local Public Agency authorizing the Contractor to proceed with the change. No claim for an adjustment of the Contract price will be valid unless so ordered.

After the work is complete, a final change order may be prepared to be accepted by the Owner and Contractor to adjust final payment as required to cover the actual units of work acceptably completed.

If the applicable unit prices are contained in the Proposal (established as a result of either a unit price or a Supplemental Schedule of Unit Prices) the Local Public Agency may order the Contractor to proceed with desired changes in the work, the value of such changes to be determined by the measured quantities involved and the applicable unit and lump sum prices specified in the Contract; provided that in case of a unit price Contract the net value of all changes does not increase or decrease the original total amount shown in the Agreement by more than twenty-five (25) percent in accordance with the section entitled BALANCED BID; VARIATION IN QUANTITIES under INSTRUCTIONS TO BIDDERS.

If applicable unit prices are not contained in the Unit Price Schedule as described above or if the total net change increases or decreases the total Contract price more than twenty-five (25) percent, the Local Public Agency shall, before ordering the Contractor to proceed with a desired change, request an itemized Proposal from him covering the work involved in the change after which the procedure shall be as follows:

- (1) If the Proposal is acceptable the Local Public Agency will prepare the Change Order in accordance therewith for acceptance by the Contractor and

- (2) If the Proposal is not acceptable and prompt agreement between the two (2) parties cannot be reached, the Local Public Agency may order the Contractor to proceed with the work on a Force Account basis, under which the net cost shall be the sum of the actual costs that follow:
- (A) Labor, including foremen;
 - (B) Materials entering permanently into the work;
 - (C) The ownership or rental cost of construction plant and equipment during the time of use on the extra work;
 - (D) Power and consumable supplies for the operation of power equipment;
 - (E) Insurance;
 - (F) Social Security and old age and unemployment contributions.

To the net cost shall be added a fixed fee agreed upon, but not to exceed fifteen (15) percent of the net cost, to cover supervision, overhead, bond, and any other general expense, and profit.

Each Change Order shall include in its final form:

- (1) A detailed description of the change in the work.
- (2) The Contractor's Proposal (if any) or a conformed copy thereof.
- (3) A definite statement as to the resulting change in the Contract price and/or time.
- (4) The statement that all work involved in the change shall be performed in accordance with Contract requirements except as modified by the Change Order.

GC.14 CLAIMS FOR EXTRA COST

If the Contractor claims that any instructions by Drawings or otherwise involve extra cost or extension of time, he shall, within ten (10) days after the receipt of such instructions, and in any event before proceeding to execute the work, submit his protest thereto in writing to the Local Public Agency, stating clearly and in detail the basis of his objections. No such claim will be considered unless so made.

Claims for additional compensation for extra work, due to alleged errors in ground elevations, contour lines, or bench marks, will not be recognized unless accompanied by certified survey data made prior

to the time the original ground was disturbed, clearly showing that errors exist which resulted or would result in handling more material, or performing more work, than would be reasonably estimated from the Drawings and maps issued.

Any discrepancies which may be discovered between actual conditions and those represented by the Drawings and maps shall at once be reported to the Local Public Agency, and work shall not proceed except at the Contractor's risk, until written instructions have been received by him from the Local Public Agency.

If, on the basis of the available evidence, the Local Public Agency determines that an adjustment of the Contract Price and/or Time is justifiable, the procedure shall then be as provided in the Section entitled CHANGES IN THE WORK under GENERAL CONDITIONS.

GC.15 OWNER'S RIGHT TO TERMINATE CONTRACT

Termination for Cause

If the Contractor shall be adjudged as bankrupt or shall file a petition for an arrangement or reorganization under the Bankruptcy Act, or if he should make a general assignment for the benefit of his creditors, or if a receiver should be appointed on account of his insolvency, or if he should persistently or repeatedly refuse or should fail, except under conditions where extension of time is approved, to supply adequate workmen, equipment and material, or disregard laws, ordinances, or the instructions of the Engineer, or otherwise be guilty of a violation of any provisions of the Contract; provided further that if the Contractor at any time fails to comply with any applicable Federal or State regulation which prevents either the Local Public Agency or the Contractor from fulfilling its obligations under these Contract Documents, then the Owner upon certification of the Engineer that sufficient cause exists to justify such action may, without prejudice to any other right or remedy, and after giving the Contractor ten (10) days' written notice, terminate the employment of the Contractor.

At the expiration of the said ten (10) days, the Owner may immediately serve notice upon the Surety to complete the work.

In the case the Surety fails to comply with the notice within thirty (30) days after service of such notice, the Owner may complete the work and charge the expense of the completion, including labor, materials, tools, implements, machinery, or apparatus, to said Contractor; and the expense so charged shall be deducted and paid by the Owner out of such monies as may be due, or that may thereafter at any time become due to the Contractor under and by virtue of this Contract. And in case such expense is less than the sum which would have been payable under this Contract if the same had been completed by the Contractor, then said Contractor shall be entitled to receive the difference. And in case such expense is greater than the sum which would have been payable under this Contract if the same had been completed by said Contractor, then the Contractor and his Surety shall pay the amount of such excess to the Owner, on demand from said Owner or Engineer of the amount so due.

Termination for Convenience

The City of Jonesboro may, by written notice to the Contractor, terminate this contract without cause. The City must give notice of termination to the Contractor at least ten (10) days prior to the effective date of termination.

Upon receipt of written notice from the Owner of such termination for the Owner's convenience, the Contractor shall:

- (1) cease operations as directed by the Owner in the notice;
- (2) take actions necessary, or that the Owner may direct, for the protection and preservation of the Work; and
- (3) except for Work directed to be performed prior to the effective date of termination stated in the notice, terminate all existing Subcontracts and purchase orders and enter into no further Subcontracts and purchase orders.

In case of such termination for the Owner's convenience, the Contractor shall be entitled to receive payment for Work executed, and actual costs incurred directly as a result of such termination, and there will be no compensation for overhead and profit on work not executed.

GC.16 SUSPENSION OF WORK

Should contingencies arise to make such action necessary, the Owner shall have the right to suspend the whole or any part of the work for a period not to exceed sixty (60) days by giving the Contractor notice in writing three (3) days prior to the suspension.

The Contractor after written notice to resume work shall begin within ten (10) days from the date of such notice.

If the work or any part thereof shall be stopped by the Owner's notice and the Owner fails to notify the Contractor to resume work within sixty (60) days, the Contractor may abandon that portion of the work so suspended and the Contractor shall be paid for all work performed on the portion so suspended at unit prices quoted in the Unit Price Schedule for completed work involved, at agreed prices on any extra work involved, and at a fair and equitable price for partially completed work involved.

The Engineer may suspend work pending the settlement of any controversy. The Contractor shall not be entitled to any claim for loss or damage by reason of such delay, nor shall he be entitled to any extension of time; but an extension may be granted by the Owner at his discretion.

GC.17 DELAYS - EXTENSION OF TIME - LIQUIDATED DAMAGES

If the Contractor is delayed at any time in the progress of the work by any act or neglect of the Owner, the Owner's Engineer or employees, or by any separate contractor employed by the Owner, or by changes ordered in the work, or by strikes, lock-outs, fire, unusual delay in transportation, unavoidable casualty, or any other cause beyond the Contractor's control, then the time of completion shall be extended for such reasonable time as the Owner may decide; provided, however, said time of completion shall be extended upon the following conditions and no other.

- 1) Requests for extension of time shall be in writing. No extension of time shall be granted automatically.
- 2) The Contractor claiming an extension of time because of any of the contingencies hereinabove mentioned, shall, within ten (10) days of the occurrence of the contingency which justifies the delay, notify the Owner in writing of his claim and the reasons therefore.
- 3) In event of a continuing cause of delay, only one claim is necessary.

GC.17.1 Excusable Delays: The right of the Contractor to proceed shall not be terminated nor shall the Contractor be charged with liquidated damages for any delays in the completion of the work due:

- (1) To any acts of the Government, including controls or restrictions upon requisitioning of materials, equipment, tools, or labor by reason of war, National Defense, or any other national emergency;
- (2) To any acts of the Owner;
- (3) To causes not reasonable foreseeable by the parties of this Contract which are beyond the control and without the fault or negligence of the Contractor, including, but not restricted to, acts of God or of the public enemy, acts of another Contractor in the performance of some other Contract with the Owner, fires, floods, epidemics, quarantine restrictions, strikes, freight embargoes, and weather of unusual severity such as hurricanes, tornadoes, cyclones, and other extreme weather conditions.
- (4) To any delay of any subcontractor occasioned by any of the causes specified in subparagraphs (1), (2), and (3) of this paragraph.

It is acknowledged between the parties to this Contract that the work to be performed by the Contractor will result in a benefit to the Owner and that a delay in completion of the work will be detrimental to the Owner. It is further acknowledged that, while work is in progress, the Owner shall incur an indeterminable amount of expense as a result of necessary supervision of the work and other

overhead and administrative expenses.

It is, therefore, agreed that if there is a delay in the completion of the work beyond the period elsewhere herein specified which has not been authorized by the Owner as set forth above, then the Owner may deduct from the Contract price the amount stated in the Special Conditions, bound herewith, as liquidated damages.

GC.18 DISPUTES

All disputes arising under this Contract or its interpretation, whether involving law or fact or both, or extra work, and all claims for alleged breach of Contract shall within ten (10) days of commencement of the dispute be presented by the Contractor to the Local Public Agency for decision. All papers pertaining to claims shall be filed in quadruplicate. Such notice need not detail the amount of the claim, but shall state the facts surrounding the claim in sufficient detail to identify the claim, together with its character and scope. In the meantime, the Contractor shall proceed with the work as directed. Any claim not presented within the time limit specified within this paragraph shall be deemed to have been waived, except that if the claim is of a continuing character and notice of the claim is not given within ten (10) days of its commencement, the claim will be considered only for a period commencing ten (10) days prior to the receipt by the Local Public Agency of notice thereof.

The Contractor shall submit in detail his claim and his proof thereof. Each decision by the governing body of the Local Public Agency will be in writing and will be mailed to the Contractor by registered mail, with return of receipt requested.

If the Contractor does not agree with any decision of the Local Public Agency, he shall in no case allow the dispute to delay the work, but shall notify the Local Public Agency promptly that he is proceeding with the work under protest, and he may then except the matter in question from the final release.

GC.19 ASSIGNMENT OR NOVATION

The Contractor shall not assign or transfer, whether by an assignment or novation, any of its rights, duties, benefits, obligations, liabilities, or responsibilities under this Contract without the written consent of the local Public Agency; provided, however, that assignments to banks, trust companies, or other financial institutions may be made without the consent of the Local Public Agency. No assignment or novation of this Contract shall be valid unless the assignment or novation expressly provides that the assignment of any of the Contractor's rights or benefits under the Contract is subject to a prior lien for labor performed, services rendered, and materials, tools, and equipment, supplied for the performance of the work under this Contract in favor of all persons, firms, or corporations rendering such labor or services or supplying such materials, tools, or equipment.

GC.20 TECHNICAL SPECIFICATIONS AND DRAWINGS

The Drawings and this Specification are to be considered cooperative. All work necessary for the completion of the facility shown on the Drawings, but not described in this Specification, or described in this Specification but not shown on the Drawings, OR REASONABLY IMPLIED BY EITHER OR BOTH, shall be executed in the best manner, the same as if fully shown and specified. When no figures or memoranda are given, the Drawings shall be accurately followed, according to their scale, but in all cases of discrepancy in figures or details, the decision of the Engineer shall be obtained before proceeding with the Work. If the Contractor adjusts any such discrepancy without first having obtained the approval of the Engineer, it shall be at his own risk, and he shall bear any extra expense resulting therefrom.

GC.21 SHOP DRAWINGS

Shop Drawings shall be required for all equipment, materials, and as required by the Engineer. All Shop Drawings, Machinery Details, Layout Drawings, etc., shall be submitted to the Engineer in four (4) copies for review (unless otherwise specified) sufficiently in advance of requirements to afford ample time for checking, including time for correcting, resubmitting, and rechecking if necessary. The Contractor may proceed, only at his own risk, with manufacture or installation of any equipment or work covered by said Shop Drawings, etc. until they are reviewed, and approved; and no claim, by the Contractor, for extension of the Contract time will be granted by reason of his failure in this respect.

Any Drawings submitted without the Contractor's stamp of approval will not be considered and will be returned to him for proper resubmission. If any Drawings show variations from the requirements of the Contract because of standard shop practice or other reason, the Contractor shall make specific mention of such variation in his letter of transmittal in order that, if acceptable, suitable action may be taken for proper adjustment of Contract price and/or time; otherwise, the Contractor will not be relieved of the responsibility for executing the work in accordance with the Contract even though the Drawings have been reviewed.

The review of Shop Drawings by the Engineer shall be considered an accommodation to the Contractor to assist him in the execution of the Contract. The Engineer's review of such Drawings shall not relieve the Contractor of his responsibility to perform the work in strict accordance with the Plans and Specifications, and approved changes.

If the Shop Drawing is in accordance with the Contract or involves only a minor adjustment in the interest of the Local Public Agency not involving a change in Contract price or time, the Engineer shall so stamp the Drawing and shall contain in substance the following:

"Corrections or comments made on the shop drawings during this review do not relieve contractor from compliance with requirements of the drawings and specifications. This check is only for review of general conformance with the design concept of the project and general

compliance with the information given in the contract documents. The contractor is responsible for: confirming and correlating all quantities and dimensions; selecting fabrication processes and techniques of construction; coordinating his work with that of all other trades; and performing his work in a safe and satisfactory manner".

GC.22 REQUESTS FOR SUPPLEMENTARY INFORMATION

It shall be the responsibility of the Contractor to make timely requests of the Local Public Agency for any additional information not already in his possession which should be furnished by the Local Public Agency under the terms of this Contract, and which he will require in the planning and execution of the work. Such requests may be submitted from time to time as the need is approached, but each shall be filed in ample time to permit appropriate action to be taken by all parties involved so as to avoid delay. Each request shall be in writing, and shall list the various items and the latest date by which each will be required by the Contractor. The first list shall be submitted within two (2) weeks after the Contract award and shall be as complete as possible at that time. The Contractor shall, if requested, furnish promptly any assistance and information the Engineer may require in responding to these requests of the Contractor. The Contractor shall be fully responsible for any delay in his work or to others arising from his failure to comply fully with the provisions of this Section.

GC.23 REFERENCE TO MANUFACTURER OR TRADE NAME - "OR EQUAL CLAUSE"

If the Plans, Specifications, or Contract Documents, laws, ordinances or applicable rules and regulations permit the Contractor to furnish or use a substitute that is equal to any material or equipment specified, and if the Contractor wishes to furnish or use a proposed substitute, he shall make written application to the Engineer for approval of such a substitute certifying in writing that the proposed substitute will perform adequately the functions called for in the general design, be similar and of equal substance to that specified, and be suited to the same use and capable of performing the same functions as that specified; the use of such substitute will not require revisions of related work. No substitute shall be ordered or installed without the written approval of the Engineer who will be the judge of equality and may require the Contractor to furnish such other data regarding the proposed substitute as he considers pertinent. No substitute shall be ordered or installed without such performance guarantee and bonds as the Owner may require which shall be furnished at Contractor's expense.

Where such substitutions alter the design or space requirements indicated on the Contract Drawings, detailed drawings shall be prepared and submitted by the Contractor delineating any changes in, or additions to, the work shown on the Contract Drawings, and such drawings and changes or additions to the work shall be made by the Contractor at no additional expense to the City. In all cases, the burden of proof that the material or equipment offered for substitution is equal in construction, efficiency, and service to that named on the Contract Drawings and in these Contract Documents shall rest on the Contractor, and unless the proof is satisfactory to the Engineer, the substitution will not be approved.

GC.24 SAMPLES, CERTIFICATES, AND TESTS

The Contractor shall submit all material, product, or equipment samples, descriptions, certificates, affidavits, etc., as called for in the Contract Documents or required by the Engineer, promptly after award of the Contract and acceptance of the Contractor's bond. No such material or equipment shall be manufactured or delivered to the site, except at the Contractor's own risk, until the required samples or certificates have been approved in writing by the Engineer. Any delay in the work caused by late or improper submission of samples or certificates for approval shall not be considered just cause for an extension of the Contract time. Submit four (4) copies of data for Engineer's review.

Each sample submitted by the Contractor shall carry a label giving the name of the Contractor, the project for which it is intended, and the name of the producer. The accompanying certificate or letter from the Contractor shall state that the sample complies with Contract requirements, shall give the name and brand of the product, its place of origin, the name and address of the producer, and all specifications or other detailed information which will assist the Engineer in passing upon the acceptability of the sample promptly. It shall also include the statement that all materials or equipment furnished for use in the project will comply with the samples and/or certified statements.

Approval of any materials shall be general only and shall not constitute a waiver of the Local Public Agency's right to demand full compliance with Contract requirements. After actual deliveries, the Engineer will have such check tests made as he deems necessary in each instance and may reject materials and equipment and accessories for cause, even though such materials and articles have been given general approval. If materials, equipment or accessories which fail to meet check tests have been incorporated in the work, the Engineer will have the right to cause their removal and replacement by proper materials or to demand and secure such reparation by the Contractor as is equitable, at the Contractor's expense.

Except as otherwise specifically stated in the Contract, the costs of sampling and testing will be divided as follows:

- (1) The Contractor shall furnish without extra cost, including packing and delivery charges, all samples required for testing purposes, except those samples taken on the project by the Engineer;
- (2) The Contractor shall assume all costs of re-testing materials which fail to meet Contract requirements;
- (3) The Contractor shall assume all costs of testing materials offered in substitution for those found deficient; and
- (4) All Construction materials shall be tested in accordance with AHTD Specifications and

at the contractor's expense.

GC.25 PERMITS AND CODES

The Contractor shall give all notices required by and comply with all applicable laws, ordinances, and codes of the Local Government. All construction work and/or utility installations shall comply with all applicable ordinances, and codes including all written waivers.

Should the Contractor fail to observe the foregoing provisions and proceed with the construction and/or install any utility at variance with any applicable ordinance or code, including any written waivers, the Contractor shall remove such work without cost to the Local Public Agency.

The Contractor shall at his own expense, secure and pay to the appropriate department of the Local Government the fees or charges for all permits for street pavements, sidewalks, sheds, removal of abandoned water taps, sealing of house connection drains, pavement cuts, building, electrical, plumbing, water, gas, and sewer permits required by the local regulatory body or any of its agencies.

The Contractor shall comply with applicable local laws and ordinances governing the disposal of surplus excavation, materials, debris, and rubbish on or off the site of the work, and commit no trespass on any public or private property in any operation due to or connected with the Improvements embraced in this Contract.

GC.26 CARE OF WORK

The Contractor alone shall be responsible for the safety, efficiency, and adequacy of his plant, appliances, and methods, and for any injury, including death, to any person, and for any damage to property which may result from their failure, or from their improper construction, maintenance, or operation. He shall indemnify and save harmless the Local Public Agency and the Engineer and their employees and agents, against any judgement with costs, which may be obtained as a result of such injury or property damage, because of the alleged liability of the Local Public Agency or of the Engineer.

The Contractor shall be responsible for the proper care and protection of all materials delivered and work performed until completion and final acceptance, whether or not the same has been covered in whole or in part by payments made by the Local Public Agency.

The Contractor shall provide sufficient competent watchmen, as required to protect the work both day and night, including Saturdays, Sundays, and holidays, from the time the work is commenced until final completion and acceptance.

In an emergency affecting the safety of life or property, including adjoining property, the Contractor, without special instructions or authorization from the Local Public Agency, is authorized to act at his discretion to prevent such threatened loss or injury, and he shall so act. He shall likewise act if

instructed to do so by the Local Public Agency. Any compensation claimed by the Contractor on account of such emergency work will be determined by the Local Public Agency as provided in the Section entitled CHANGES IN THE WORK under GENERAL CONDITIONS.

The Contractor shall avoid damage, as a result of his operations, to existing sidewalks, streets, curbs, pavements, utilities (except those which are to be replaced or removed), adjoining property, etc., and he shall at his own expense completely repair any damage thereto caused by his operations, to the satisfaction of the Owner.

The Contractor shall shore up, brace, underpin, secure, and protect as may be necessary, all foundations and other parts of existing structures adjacent to, adjoining, and in the vicinity of the site, which may be in any way affected by the excavations or other operations connected with the construction of the Improvements embraced in this Contract. The Contractor shall be responsible for the giving of any and all required notices to any adjoining or adjacent property owner or other party before the commencement of any work. The Contractor shall indemnify and save harmless the Local Public Agency, and the Engineer, from any damages on account of settlements or the loss of lateral support of adjoining property and from all loss or expense and all damages for which it may be claimed that the Local Public Agency, or the Engineer, is liable in consequence of such injury or damage to adjoining and adjacent structures and their premises.

GC.27 QUALITY OF WORK AND PROPERTY

All property, materials, and equipment shall be new and free of defects upon completion of the Contractor's performance and, unless different standards are specified elsewhere in the Contract Documents, shall be of the best type and quality available for the purpose. All of the Contractor's work shall be performed with the highest degree of skill and completed free of defects and in accordance with the Contract Documents. Any work, property, materials, or equipment not in conformance with these standards shall be considered defective. If any work, property, materials or equipment is discovered to have been defective or not in conformance with the Contract Documents, whether said discovery is made before or after completion of performance, the Contractor, at his expense, after written notice from the Owner or Engineer, shall promptly replace or correct the deficiency and pay any engineering costs and consequential expense or damage incurred by the Owner in connection therewith. If the Contractor fails to promptly correct all deficiencies, the Owner shall have the option of remedying the defects at the Contractor's cost. If the Contractor is required to furnish shop drawings or designs, the above provisions shall apply to such drawings or designs.

Neither the Owner's payment, acceptance, inspection or use of the work, property, materials, or equipment, nor any other provision of the Contract Documents shall constitute acceptance of work, property, materials, or equipment which are defective or not in accordance with the Contract Documents. If the Contractor breaches any provision of the Contract Documents with respect to the quality of the work, property, materials, equipment or performance, whether initial or corrective, his liability to the Owner shall continue until the statute of limitations with respect to such breach of

contract has expired following discovery of the defect. All parts of this section are cumulative to any other provisions of the Contract Documents and not in derogation thereof. If it is customary for a warranty to be issued for any of the property to be furnished hereunder, such warranty shall be furnished, but no limitations in any such warranty shall reduce the obligations imposed under the Contractor in the Contract Documents or by Arkansas Law; but if any greater obligations than imposed in this Contract are specified in any such warranty or by Arkansas Law, those greater obligations shall be deemed a part of this Contract and enforceable by the Owner.

GC.28 ACCIDENT PREVENTION

The Contractor shall exercise proper precaution at all times for the protection of persons and property and shall be responsible for all damages to persons or property, either on or off the site, which occur as a result of his prosecution of the work. The safety provisions of applicable laws and building and construction codes, including applicable parts of the Arkansas Department of Labor Safety Code, shall be observed. The Contractor shall take or cause to be taken such safety and health measures, additional to those herein required, as he may deem necessary or desirable. Machinery, equipment, and all hazards shall be guarded in accordance with the safety provisions of the "Manual of Accident Prevention in Construction" published by the Associated General Contractors of America, Inc., to the extent that such provisions are not in conflict with applicable local laws.

The Contractor shall maintain an accurate record of all cases of death, occupational disease, and injury requiring medical attention or causing loss of time from work, arising out of and in the course of employment on work under the Contract. The Contractor shall promptly furnish the Local Public Agency with reports concerning these matters.

The Contractor shall indemnify and save harmless the Local Public Agency, and the Engineer, from any claims for damages resulting from personal injury and/or death suffered or alleged to have been suffered by any person as a result of any work conducted under this Contract.

GC.29 SANITARY FACILITIES

The Contractor shall furnish, install, and maintain ample sanitary facilities for the workers. As the needs arise, a sufficient number of enclosed temporary toilets shall be conveniently placed as required by the sanitary codes of the State and Local Government. Drinking water shall be provided from an approved source, so piped or transported as to keep it safe and fresh and served from single service containers or satisfactory types of sanitary drinking stands or fountains. All such facilities and services shall be furnished in strict accordance with existing and governing health regulations.

GC.30 USE OF PREMISES

The Contractor shall confine his equipment, storage of materials, and construction operations to the Rights-of-Way to accommodate the permanent construction furnished by the Local Public Agency, or

as may be directed otherwise by the Local Public Agency, and shall not unreasonably encumber the site of other public Rights-of-Way with his materials and construction equipment. In case such Rights-of-Way furnished by the Local Public Agency are not sufficient to accommodate the Contractor's operations, he shall arrange with the Local Government, or with the owner or owners of private property for additional area or areas, and without involving the Local Public Agency in any manner whatsoever.

The Contractor shall comply with all reasonable instructions of the Local Public Agency and the ordinances and codes of the Local Government (including but not limited to those) regarding signs, advertising, traffic, fires, explosives, danger signals, and barricades.

GC.31 REMOVAL OF DEBRIS, CLEANING, ETC.

The Contractor shall periodically or as directed during the progress of the work, remove and legally dispose of all surplus excavated material and debris, and keep the project site and public Rights-of-Way reasonably clear. Upon completion of the work, he shall remove all temporary construction facilities, debris, and unused materials provided for the work, thoroughly clean all drainage pipes, structures, ditches, and other features, and put the whole site of the work and public Rights-of-Way in a neat and "broom" clean condition. Trash burning on the site of the work will be subject to prior approval of the Jonesboro Fire Department.

GC.32 RETURN OF OWNER'S MATERIALS, EQUIPMENT OR PROPERTY

Any materials, equipment or other property which belongs to the Owner, removed by the Contractor, shall be delivered to the Owner's designated warehouse unless its re-use is specified in the Plans and Specifications. If the Contractor fails to deliver the materials, equipment, or other property, the value, as determined by the Engineer, shall be deducted from amounts due the Contractor.

GC.33 OBSERVATION OF WORK

The Engineer, his authorized representative, and any Federal, State, County, or local authority representative having jurisdiction over any part of the work, or area through which the work is located, shall at all times have access to the work in progress.

The detailed manner and method of performing the work shall be under the direction and control of the Contractor, but all work performed shall at all times be subject to the observation of the Engineer or his authorized representative to ascertain its conformance with the Contract Documents. The Contractor shall furnish all reasonable aid and assistance required by the Engineer for the proper observation and examination of the work and all parts thereof.

The Engineer is not responsible for the Contractor's means, methods, techniques, sequences, or procedures of construction, or safety precautions and programs incident thereto.

Observers may be appointed by the Engineer or Owner. Observers shall have no authority to permit any deviation from the Plans and Specifications except on written order from the Engineer and the Contractor will be liable for any deviation except on such written order. Observers shall have authority, subject to the final decision of the Engineer, to condemn and reject any defective work and to suspend the work when it is not being performed properly.

The observer shall in no case act as superintendent or foreman or perform other duties for the Contractor, nor interfere with the management of the work by the latter. Any advice which the observer may give the Contractor shall in no way be construed as binding to the Engineer in any way or releasing the Contractor from fulfilling all of the terms of the Contract.

Any defective work may be rejected by the Engineer at any time before final acceptance of the work, even though the same may have been previously overlooked and estimated for payment and payment therefore made by the Owner.

The Contractor shall notify the Engineer sufficiently in advance of backfilling or concealing any facilities to permit proper observation. If the facilities are concealed without approval or consent of the Engineer, the Contractor shall uncover for observation and recover such facilities all at his own expense, when so requested by the Engineer.

Should it be considered necessary or advisable by the Engineer at any time before final acceptance of the entire work to make an examination of work already completed, by uncovering the same, the Contractor shall on request promptly furnish all necessary facilities, labor, and material. If such work is found to be defective in any important or essential respect, due to fault of the Contractor or his Subcontractors, he shall defray all the expenses of such examination and of satisfactory reconstruction. If, however, such work is found to meet the requirements of the Contract, the actual cost of labor and material necessarily involved in the examination and replacement, plus fifteen (15) percent of such costs to cover superintendence, general expenses and profit, shall be allowed the Contractor and he shall, in addition, if completion of the work of the entire Contract has been delayed thereby, be granted a suitable extension of time on account of the additional work involved.

Observation of materials and appurtenances to be incorporated in the Improvements embraced in this Contract may be made at the place of production, manufacture or shipment, whenever the quantity justifies it, and such observation and acceptance, unless otherwise stated in the Technical Specifications, shall be final, except as regards (1) latent defects, (2) departures from specific requirements of the Contract, (3) damage or loss in transit, or (4) fraud or such gross mistakes as amount to fraud. Subject to the requirements contained in the preceding sentence, the observation of materials as a whole or in part will be made at the project site.

All condemned or rejected work shall be promptly taken out and replaced by satisfactory work. Should the Contractor fail or refuse to comply with the instructions in this respect, the Owner may, upon certification by the Engineer, withhold payment, proceed to terminate the Contract, or perform work as provided herein.

GC.34 REVIEW BY LOCAL PUBLIC AGENCY OR OWNER

The Local Public Agency, its authorized representatives and agents, shall at all times during work hours have access to and be permitted to observe and review all work, materials, equipment, payrolls, and personnel records pertaining to this Contract, provided, however, that all instructions and approval with respect to the work will be given to the Contractor only by the Local Public Agency through its authorized representatives or agents. Representatives of Federal, State, and local government agencies also have the right of physical inspection of the work during work hours.

GC.35 PROHIBITED INTERESTS

No official of the Owner who is authorized in such capacity and on behalf of the Owner to negotiate, make, accept or approve, or to take part in negotiating, making, accepting, or approving any architectural, engineering, inspection, construction or material supply contract or any subcontract in connection with the construction of the project, shall become directly or indirectly interested personally in this Contract or in any part thereof. No officer, employee, architect, attorney, engineer, or inspector of or for the Owner who is authorized in such capacity and on behalf of the Owner to exercise any executive, supervisory, or other similar functions in connection with the construction of the project, shall become directly or indirectly interested personally in this Contract or in any part thereof.

GC.36 FINAL INSPECTION

When the Improvements embraced in this Contract are substantially completed, the Contractor shall notify the Local Public Agency in writing that the work will be ready for final inspection on a definite date which shall be stated in the notice. The notice will be given at least ten (10) days prior to the date stated for final inspection, and bear the signed concurrence of the representative of the Local Public Agency having charge of observation. If the Local Public Agency determines that the status of the Improvements is as represented, it will make the arrangements necessary to have final inspection commenced on the date stated in the notice, or as soon thereafter as practicable. The inspection party will also include the representatives of each Department of the Local Government and any other involved government agencies when such improvements are later to be accepted by the Local Government and/or other government agencies.

GC.37 PATENTS

The Contractor shall hold and save harmless the Local Public Agency, its officers, employees, and the Engineer, from liability of any nature or kind, including costs and expenses, for, or on account of, any patented or unpatented invention, process, article, or appliance manufactured or used in the performance of the Contract, including its use by the Local Public Agency, unless otherwise specifically stipulated in the Technical Specifications.

GC.38 WARRANTY OF TITLE

No material, supplies, or equipment for the work shall be purchased subject to any chattel mortgage or under a conditional sale or other agreement by which an interest therein or in any part thereof is retained by the seller or supplier. The Contractor shall warrant good title to all materials, supplies, and equipment installed or incorporated in the work and upon completion of all work, shall deliver the same together with all improvements and appurtenances constructed or placed thereon by him to the Local Public Agency free from any claims, liens, or charges. Neither the Contractor nor any person, firm or corporation furnishing any material or labor for any work covered by this Contract, shall have any right to a lien upon any improvement or appurtenance thereon. Nothing contained in this paragraph, however, shall defeat or impair the right of persons furnishing materials or labor to recover under any bond given by the Contractor for their protection or any rights under any law permitting such persons to look to funds due the Contractor in the hands of the Local Public Agency. The provisions of this paragraph shall be inserted in all subcontracts and material Contracts and notice of its provisions shall be given to all persons furnishing materials for the work when no formal Contract is entered into for such materials.

GC.39 GENERAL GUARANTY

Neither the final certificate of payment nor any provision in the Contract nor partial or entire use of the Improvements embraced in this Contract by the Local Public Agency or the public shall constitute an acceptance of work not done in accordance with the Contract or relieve the Contractor of liability in respect to any express warranties or responsibility for faulty materials or workmanship. The Contractor shall promptly remedy any defects in the work and pay for any damage to other work resulting therefrom which shall appear within a period of twelve (12) months from the agreed upon day of final acceptance of the work. The Local Public Agency will give notice of defective materials and work with reasonable promptness.

XVI. SUPPLEMENTAL GENERAL CONDITIONS

TABLE OF CONTENTS

SGC.1	PROGRESS SCHEDULE
SGC.2	DRAWINGS
SGC.3	ADDITIONAL INSURANCE
SGC.4	RECORD DRAWINGS
SGC.5	TRENCH AND EXCAVATION SAFETY SYSTEMS
SGC.6	MINIMUM WAGES
SGC.7	DAVIS-BACON

SGC.1 PROGRESS SCHEDULE

The Contractor shall submit a construction contract schedule of the bar graph (or other approved) type seven (7) calendar days prior to the preconstruction conference showing the following information as a minimum:

- (1) Actual date construction is scheduled to start if different from the date of notice to proceed.
- (2) Planned contract completion date.
- (3) Beginning and completion dates for each phase of work.
- (4) Respective dates for submission of shop drawings and the beginning of manufacture, the testing of, and the installation of materials, supplies, and equipment.
- (5) All construction milestone dates.
- (6) A separate graph showing work placement in dollars versus contract time. The schedule shall incorporate contract changes as they occur. The schedule shall be maintained in an up-to-date condition and shall be available for inspection at the construction site at all times.

The construction contract schedule shall be submitted in conjunction with and/or in addition to any other specification requirements concerning schedules.

SGC.2 DRAWINGS

One (1) set of Plans and Specifications shall be furnished to the Contractor, at no charge, for construction purposes. Additional copies may be obtained at cost of reproduction upon request.

The Contractor shall keep one (1) copy of all drawings and Contract Documents in good condition readily accessible at the site of the work available to the Engineer and his authorized representatives.

SGC.3 ADDITIONAL INSURANCE (i.e. Railroad Insurance)

Intentionally Left Blank

SGC.4 RECORD DRAWINGS

Before any work is started, the Contractor shall obtain at his own expense one set of Plans to be used for Record Drawings. The Engineer will supply the Plans at printing cost to the Contractor. Record Drawings will be kept on full-size plan sheets; no half-size sheets will be permitted. The Record Drawings shall be stored and maintained in good condition at all times by the Contractor and shall be

made available to the Engineer at the work site immediately at the Engineer's request. All writing, notes, comments, dimensions, etc. shall be legible. The Record Drawings shall be stored flat and shall not be rolled. The Record Drawings shall be submitted to the Engineer before the project can be accepted.

The Contractor shall accurately identify and document the locations of all underground and/or concealed work that he has performed and/or has been affected by his work. This shall include all equipment, conduits, pipe lines, valves, fittings and other appurtenances and underground structures that are part of the Contractor's work and their proximity to existing underground structures and utilities to the extent known. The Contractor will certify accuracy of the Record Drawings by endorsement.

The Contractor's work shall be documented on the Record Drawings in an on-going manner. Distances, offsets, depths, etc. shall be accurately measured from permanent fixed objects so that the Owner can expose any item of the work in the future with a minimum of effort. All such measurements shall be made before the items of work are covered or backfilled. The Contractor shall be required to expose and recover/backfill the work at his own expense if, in the Engineer's opinion, the measurements need to be verified.

SGC.5 TRENCH AND EXCAVATION SAFETY SYSTEM

This section covers trench and excavation safety system required for constructing improvements that necessitate open excavations on the project. All work under this item shall be in accordance with the current edition of the "Occupational Safety and Health Administration Standard for Excavation and Trenches Safety System, 29 CFR 1926, Subpart P.

The Contractor, prior to beginning any excavation, shall notify the State Department of Labor (Safety Division) that work is commencing on a project with excavations greater than five feet.

The Contractor shall notify all Utility Companies and Owners in accordance with OSHA Administration 29 CFR 1926.651(b) (2) for the purpose of locating utilities and underground installations.

Where the trench or excavation endangers the stability of a building, wall, street, highway, utilities, or other installation, the Contractor shall provide support systems such as shoring, bracing, or underpinning to ensure the stability of such structure or utility.

The Contractor may elect to remove and replace or relocate such structures or utilities with the written approval of the Owner of the structure or utility and the Project Owner.

The work required by this item will be paid for at the price bid for "Trench and Excavation Safety Systems". After award of the contract, the Contractor shall submit to the Engineer a breakdown of cost for work involved in the price bid for "Trench and Excavation Safety Systems" and shall, with each periodic payment request, submit a certification by the Contractor's "competent person" as defined in Subpart "P" 1926.650(b) that the Contractor has complied with the provisions of "Occupational Safety and Health Administration Standard for Excavation and Trenches Safety System", 29 CFR 1926 Subpart

P for work for which payment is requested.

SGC.6 MINIMUM WAGES

The Contractor shall comply with the wage provisions of the Davis Bacon Act and the administrative regulations promulgated thereunder, as they apply under this Contract.

It shall be the responsibility of each Bidder to determine the consequences of the applicable wage provisions of the Davis Bacon Act, and include in his bid any costs made necessary because of them. No additional payment will be made, and no extension of Contract time will be allowed because of the provisions of the Act.

The Contractor shall comply with all applicable wage provisions of the Davis Bacon Act including the following:

- (1) Pay wage rates not less than the prevailing hourly wage for each craft or type of workman needed to execute the Contract, as determined by the United States Department of Labor. Such determination covering rates for regular hours, fringe benefits, and rates for holidays and overtime are listed on the following page.
- (2) Post on the site of the work, in a conspicuous and accessible place, a copy of the prevailing wage rates as determined by the United States Department of labor.
- (3) Keep an accurate record of workman employed by him, and by each subcontractor, if any, including the wage payments made. Such record, or records, shall be available for inspection by the United States Department of Labor, and the Owner, during reasonable hours.
- (4) The Contractor's bond shall guarantee the payment of wages as herein specified.

Wage rates as established by the United States Department of Labor are minimums for wage payments under this Contract.

There is no assurance on the part of the Owner that mechanics and laborers can be obtained for the rates herein bound. Each Bidder shall determine for himself the availability of laborers and mechanics, and the rates he must pay to obtain employees. Such rates of pay may be greater than, but cannot be less than, the wage rates bound herein.

>

General Decision Number: AR140175 02/07/2014 AR175

Superseded General Decision Number: AR20130175

State: Arkansas

Construction Type: Heavy
Heavy Construction

Counties: Craighead and Poinsett Counties in Arkansas.

Modification Number	Publication Date
0	01/03/2014
1	02/07/2014

* ENGI0624-003 01/01/2014

	Rates	Fringes
Operating Engineer:		
Roller (Dirt and Grade Compaction).....	\$ 24.30	11.30

PAIN0424-007 07/01/2013

	Rates	Fringes
PAINTER: Brush and Roller.....	\$ 14.60	6.42

SUAR2008-172 11/21/2008

	Rates	Fringes
CARPENTER.....	\$ 14.55	0.00
CEMENT MASON/CONCRETE FINISHER...	\$ 15.54	0.00
ELECTRICIAN.....	\$ 19.16	4.12
IRONWORKER, REINFORCING.....	\$ 17.38	0.00
LABORER: Common or General.....	\$ 9.90	2.23
LABORER: Mason Tender - Cement/Concrete.....	\$ 11.67	0.00
OPERATOR: Backhoe/Excavator/Trackhoe.....	\$ 13.74	0.00
OPERATOR: Bulldozer.....	\$ 12.00	0.00
OPERATOR: Crane.....	\$ 19.26	0.00
OPERATOR: Loader (Front End)....	\$ 13.42	0.00
OPERATOR: Mechanic.....	\$ 17.25	0.00

OPERATOR: Piledriver.....	\$ 17.21	0.00
OPERATOR: Scraper.....	\$ 9.00	0.00
OPERATOR: Tractor.....	\$ 11.13	0.00
OPERATOR: Trencher.....	\$ 14.76	0.00
PAINTER: Spray.....	\$ 20.15	3.50
TRUCK DRIVER.....	\$ 9.00	0.00

WELDERS - Receive rate prescribed for craft performing operation to which welding is incidental.

Unlisted classifications needed for work not included within the scope of the classifications listed may be added after award only as provided in the labor standards contract clauses (29CFR 5.5 (a) (1) (ii)).

The body of each wage determination lists the classification and wage rates that have been found to be prevailing for the cited type(s) of construction in the area covered by the wage determination. The classifications are listed in alphabetical order of "identifiers" that indicate whether the particular rate is union or non-union.

Union Identifiers

An identifier enclosed in dotted lines beginning with characters other than "SU" denotes that the union classification and rate have found to be prevailing for that classification. Example: PLUM0198-005 07/01/2011. The first four letters , PLUM, indicate the international union and the four-digit number, 0198, that follows indicates the local union number or district council number where applicable , i.e., Plumbers Local 0198. The next number, 005 in the example, is an internal number used in processing the wage determination. The date, 07/01/2011, following these characters is the effective date of the most current negotiated rate/collective bargaining agreement which would be July 1, 2011 in the above example.

Union prevailing wage rates will be updated to reflect any changes in the collective bargaining agreements governing the rates.

0000/9999: weighted union wage rates will be published annually each January.

Non-Union Identifiers

Classifications listed under an "SU" identifier were derived from survey data by computing average rates and are not union rates; however, the data used in computing these rates may include both union and non-union data. Example: SULA2004-007 5/13/2010. SU indicates the rates are not union majority rates, LA indicates the State of Louisiana; 2004 is the year of the survey; and 007 is an internal number used in producing the wage determination. A 1993 or later date, 5/13/2010, indicates the classifications and rates under that identifier were issued as a General Wage Determination on that date.

Survey wage rates will remain in effect and will not change until a new survey is conducted.

WAGE DETERMINATION APPEALS PROCESS

1.) Has there been an initial decision in the matter? This can be:

- * an existing published wage determination
- * a survey underlying a wage determination
- * a Wage and Hour Division letter setting forth a position on a wage determination matter
- * a conformance (additional classification and rate) ruling

On survey related matters, initial contact, including requests for summaries of surveys, should be with the Wage and Hour Regional Office for the area in which the survey was conducted because those Regional Offices have responsibility for the Davis-Bacon survey program. If the response from this initial contact is not satisfactory, then the process described in 2.) and 3.) should be followed.

With regard to any other matter not yet ripe for the formal process described here, initial contact should be with the Branch of Construction Wage Determinations. Write to:

Branch of Construction Wage Determinations
Wage and Hour Division
U.S. Department of Labor
200 Constitution Avenue, N.W.
Washington, DC 20210

2.) If the answer to the question in 1.) is yes, then an interested party (those affected by the action) can request review and reconsideration from the Wage and Hour Administrator (See 29 CFR Part 1.8 and 29 CFR Part 7). Write to:

Wage and Hour Administrator
U.S. Department of Labor
200 Constitution Avenue, N.W.
Washington, DC 20210

The request should be accompanied by a full statement of the

interested party's position and by any information (wage payment data, project description, area practice material, etc.) that the requestor considers relevant to the issue.

3.) If the decision of the Administrator is not favorable, an interested party may appeal directly to the Administrative Review Board (formerly the Wage Appeals Board). Write to:

Administrative Review Board
U.S. Department of Labor
200 Constitution Avenue, N.W.
Washington, DC 20210

4.) All decisions by the Administrative Review Board are final.

=====

END OF GENERAL DECISION

PAYROLL

(For Contractor's Optional Use; See Instructions at www.dol.gov/whd/forms/wh347instr.htm)



Rev. Dec. 2008

Persons are not required to respond to the collection of information unless it displays a currently valid OMB control number.

OMB No.: 1235-0008
Expires: 01/31/2015

NAME OF CONTRACTOR	OR SUBCONTRACTOR	ADDRESS
--------------------	------------------	---------

PAYROLL NO.	FOR WEEK ENDING	PROJECT AND LOCATION	PROJECT OR CONTRACT NO.
-------------	-----------------	----------------------	-------------------------

(1) NAME AND INDIVIDUAL IDENTIFYING NUMBER (e.g., LAST FOUR DIGITS OF SOCIAL SECURITY NUMBER) OF WORKER	(2) NO. OF WITHHOLDING EXEMPTIONS	(3) WORK CLASSIFICATION	OT. OR ST.	(4) DAY AND DATE							(5) TOTAL HOURS	(6) RATE OF PAY	(7) GROSS AMOUNT EARNED	(8) DEDUCTIONS					(9) NET WAGES PAID FOR WEEK
				HOURS WORKED EACH DAY										FICA	WITH- HOLDING TAX	OTHER	TOTAL DEDUCTIONS		
			O																
			S																
			O																
			S																
			O																
			S																
			O																
			S																
			O																
			S																
			O																
			S																

While completion of Form WH-347 is optional, it is mandatory for covered contractors and subcontractors performing work on Federally financed or assisted construction contracts to respond to the information collection contained in 29 C.F.R. §§ 3.3, 5.5(a). The Copeland Act (40 U.S.C. § 3145) contractors and subcontractors performing work on Federally financed or assisted construction contracts to "furnish weekly a statement with respect to the wages paid each employee during the preceding week." U.S. Department of Labor (DOL) regulations at 29 C.F.R. § 5.5(a)(3)(ii) require contractors to submit weekly a copy of all payrolls to the Federal agency contracting for or financing the construction project, accompanied by a signed "Statement of Compliance" indicating that the payrolls are correct and complete and that each laborer or mechanic has been paid not less than the proper Davis-Bacon prevailing wage rate for the work performed. DOL and federal contracting agencies receiving this information review the information to determine that employees have received legally required wages and fringe benefits.

Public Burden Statement

We estimate that it will take an average of 55 minutes to complete this collection, including time for reviewing instructions, searching existing data sources, gathering and maintaining the data needed, and completing and reviewing the collection of information. If you have any comments regarding these estimates or any other aspect of this collection, including suggestions for reducing this burden, send them to the Administrator, Wage and Hour Division, U.S. Department of Labor, Room S3502, 200 Constitution Avenue, N.W. Washington, D.C. 20210

Date _____

I, _____
(Name of Signatory Party) (Title)

do hereby state:

(1) That I pay or supervise the payment of the persons employed by

_____ on the
(Contractor or Subcontractor)

_____;
(Building or Work)

_____ day of _____, _____, and ending the _____ day of _____, _____,
all persons employed on said project have been paid the full weekly wages earned, that no rebates have
been or will be made either directly or indirectly to or on behalf of said

_____ from the full
(Contractor or Subcontractor)

weekly wages earned by any person and that no deductions have been made either directly or indirectly
from the full wages earned by any person, other than permissible deductions as defined in Regulations, Part
3 (29 C.F.R. Subtitle A), issued by the Secretary of Labor under the Copeland Act, as amended (48 Stat. 948,
63 Stat. 108, 72 Stat. 967; 76 Stat. 357; 40 U.S.C. § 3145), and described below:

(2) That any payrolls otherwise under this contract required to be submitted for the above period are
correct and complete; that the wage rates for laborers or mechanics contained therein are not less than the
applicable wage rates contained in any wage determination incorporated into the contract; that the
classifications set forth therein for each laborer or mechanic conform with the work he performed.

(3) That any apprentices employed in the above period are duly registered in a bona fide
apprenticeship program registered with a State apprenticeship agency recognized by the Bureau of
Apprenticeship and Training, United States Department of Labor, or if no such recognized agency exists in a
State, are registered with the Bureau of Apprenticeship and Training, United States Department of Labor.

(4) That:

(a) WHERE FRINGE BENEFITS ARE PAID TO APPROVED PLANS, FUNDS, OR PROGRAMS

- in addition to the basic hourly wage rates paid to each laborer or mechanic listed in
the above referenced payroll, payments of fringe benefits as listed in the contract
have been or will be made to appropriate programs for the benefit of such
employees, except as noted in section 4(c) below.

(b) WHERE FRINGE BENEFITS ARE PAID IN CASH

- Each laborer or mechanic listed in the above referenced payroll has been paid,
as indicated on the payroll, an amount not less than the sum of the applicable
basic hourly wage rate plus the amount of the required fringe benefits as listed
in the contract, except as noted in section 4(c) below.

(c) EXCEPTIONS

EXCEPTION (CRAFT)	EXPLANATION

REMARKS:

NAME AND TITLE	SIGNATURE
----------------	-----------

THE WILLFUL FALSIFICATION OF ANY OF THE ABOVE STATEMENTS MAY SUBJECT THE CONTRACTOR OR
SUBCONTRACTOR TO CIVIL OR CRIMINAL PROSECUTION. SEE SECTION 1001 OF TITLE 18 AND SECTION 231 OF TITLE
31 OF THE UNITED STATES CODE.

EMPLOYEE RIGHTS UNDER THE DAVIS-BACON ACT

FOR LABORERS AND MECHANICS EMPLOYED ON FEDERAL OR FEDERALLY ASSISTED CONSTRUCTION PROJECTS

THE UNITED STATES DEPARTMENT OF LABOR WAGE AND HOUR DIVISION

**PREVAILING
WAGES**

You must be paid not less than the wage rate listed in the Davis-Bacon Wage Decision posted with this Notice for the work you perform.

OVERTIME

You must be paid not less than one and one-half times your basic rate of pay for all hours worked over 40 in a work week. There are few exceptions.

ENFORCEMENT

Contract payments can be withheld to ensure workers receive wages and overtime pay due, and liquidated damages may apply if overtime pay requirements are not met. Davis-Bacon contract clauses allow contract termination and debarment of contractors from future federal contracts for up to three years. A contractor who falsifies certified payroll records or induces wage kickbacks may be subject to civil or criminal prosecution, fines and/or imprisonment.

APPRENTICES

Apprentice rates apply only to apprentices properly registered under approved Federal or State apprenticeship programs.

PROPER PAY

If you do not receive proper pay, or require further information on the applicable wages, contact the Contracting Officer listed below:

**Municipal Building
Grants and Community Development
300 S. Church Street
Jonesboro, AR 72401
870-336-7170**

or contact the U.S. Department of Labor's Wage and Hour Division.



For additional information:

1-866-4-USWAGE

(1-866-487-9243) TTY: 1-877-889-5627



WWW.WAGEHOUR.DOL.GOV

XVII. SPECIAL CONDITIONS

TABLE OF CONTENTS

SC.1	GENERAL
SC.2	LOCATION OF PROJECT
SC.3	SCOPE OF WORK
SC.4	TIME ALLOTTED FOR COMPLETION
SC.5	FORMS, PLANS, AND SPECIFICATIONS
SC.6	LIQUIDATED DAMAGES FOR DELAY
SC.7	KNOWLEDGE OF CONDITIONS
SC.8	PERMITS AND RIGHTS-OF-WAY
SC.9	REFERENCE SPECIFICATIONS
SC.10	PUBLIC UTILITIES AND OTHER PROPERTY TO BE CHANGED
SC.11	USED MATERIALS
SC.12	EXISTING STRUCTURES
SC.13	USE OF EXPLOSIVES
SC.14	BARRICADES, LIGHTS, AND WATCHMEN
SC.15	FENCES AND DRAINAGE CHANNELS
SC.16	WATER FOR CONSTRUCTION
SC.17	MATERIAL STORAGE
SC.18	EXISTING UTILITIES AND SERVICE LINES
SC.19	TESTING, INSPECTION AND CONTROL
SC.20	BOND
SC.21	LIGHT AND POWER
SC.22	LINES AND GRADES
SC.23	LEGAL HOLIDAYS
SC.24	SEQUENCE OF CONSTRUCTION
SC.25	TEST BORINGS
SC.26	TEMPORARY FIELD OFFICE
SC.27	RELEASE AND CONTRACTOR'S AFFIDAVIT
SC.28	MAINTENANCE BOND

SC.1 GENERAL

The provisions of this section of the Specifications shall govern in the event of any conflict between them and the "General Conditions".

SC.2 LOCATION OF PROJECT

The project is located along Dalton-Farmer Drive, Jonesboro, Arkansas. A map showing the general location is included in the plan sets.

SC.3 SCOPE OF WORK

The work to be performed under this Contract consists of furnishing all materials, labor, supervision, tools and equipment necessary to extend sanitary sewer along Dalton-Farmer Drive.

SC.4 TIME ALLOTTED FOR COMPLETION

The time allotted for completion of the work shall be ninety (90) consecutive calendar days, which time shall begin within ten (10) days of the work order or notice to proceed. After award of the Contract is made and the Contract Documents are completed, the Engineer shall issue a Notice to Proceed, notifying the Contractor to proceed with the construction of the project, subject to the provisions of this paragraph.

SC.5 FORMS, PLANS AND SPECIFICATIONS

Forms of Proposal, Contract and Bonds, and Plans and Specifications may be examined at the City of Jonesboro Engineering Department, 300 South Church Street, Jonesboro, Arkansas 72403, and obtained upon payment of \$25.00 each. No refunds will be made.

SC.6 LIQUIDATED DAMAGES FOR DELAY

The number of calendar days allowed for completion of the project is stipulated in the Proposal and in the Contract and shall be known as the Contract Time.

1. It is understood and agreed by and between the Owner and the Contractor that the time of completion herein set out is a reasonable time. The Contractor shall perform fully, entirely, and in an acceptable manner, the work contracted for within the contract time stated in the Contract. The contract time shall be counted from ten days after the effective date of the "Notice to Proceed"; and shall include all Sundays, holidays, and non-work days. All calendar days elapsing between the effective dates of any orders of the Engineer for suspension of the prosecution of the work, due to the fault of the Contractor, shall be counted as elapsed contract time, and shall not be considered for an extension of time.
2. Extensions of time for completion, under the condition of 2(a) next below, will be granted; extensions may be granted under other stated conditions:

- a. If the satisfactory execution and completion of the Contract shall require work or material in greater amounts or quantities than those set forth in the Contract, then the Contract time shall be increased in the same proportion as the additional work bears to the original work contracted for.
 - b. An average or usual number of inclement weather days, when work cannot proceed, is to be anticipated during the construction period and is not to be considered as warranting extension of time. If, however, it appears that the Contractor is delayed by conditions of weather, so unusual as not to be reasonably anticipated, extensions of time may be granted.
 - c. Should the work under the Contract be delayed by other causes which could not have been prevented or contemplated by the Contractor, and which are beyond the Contractor's power to prevent or remedy, an extension of time may be granted. Such causes of delay shall include but not necessarily be limited to the following:
 - (1) Acts of God, acts of the public enemy, acts of the Owner except as provided in these Specifications, fires, floods, epidemics, quarantine restrictions, strikes, freight embargoes, and unusually severe weather.
 - (2) Any delays of Subcontractors or suppliers occasioned by any of the causes specified above.
3. The Resident Project Representative or other authorized representative of the City shall keep a written record sufficient for determination as to the inclusion of that day in the computation of Contract time. This record shall be available for examination by the Contractor during normal hours of work as soon as feasible after the first of each construction month. In case of disagreement between the representative of the City and the Contractor, as to the classification of any day, the matter shall be referred to the City whose decision shall be final.
 4. The amount of all extensions of time for whatever reason granted shall be determined by the Owner. In general, only actual and not hypothetical days of delay will be considered. The Owner shall have authority to grant additional extensions of time as the Owner may deem justifiable.

The amount of Liquidated Damages to be assessed shall be in accordance with the schedule that follows:

<u>Amount of Contract</u>	<u>Liquidated Damages</u> <u>Per Day</u>
Less than \$25,000.00	\$100.00
Not less than \$ 25,000.00 but less than \$ 50,000.00	\$150.00
Not less than \$ 50,000.00 but less than \$ 100,000.00	\$200.00
Not less than \$100,000.00 but less than \$ 500,000.00	\$250.00
Not less than \$500,000.00 but less than \$1,000,000.00	\$350.00

Over \$1,000,000.00

\$500.00

1. Time is an essential element of the Contract and it is important that the work be pressed vigorously to completion. Loss will accrue to the public due to delayed completion of the facility; and the cost to the Owner of the administration of the Contract, including engineering, inspection and supervision, will be increased as the time occupied in the work is lengthened.
2. Should the Contractor fail to complete the work as set forth in the Specifications and within the time stipulated in the Contract, there shall be deducted the amount shown in the schedule above, for each day of delay, from any monies due or which may thereafter become due him, not as a penalty, but as ascertained and liquidated damages.
3. Should the amount otherwise due the Contractor be less than the amount of such ascertained and liquidated damages, the Contractor and his Surety shall be liable to the Owner for such deficiency.

If the Contractor finds it impossible for reasons beyond his control to complete the work within the Contract time as specified, or as extended in accordance with the provisions of this subsection, he may, at any time prior to the expiration of the Contract time as extended, make a written request to the Engineer for an extension of time setting forth the reasons which he believes will justify the granting of his request. The Contractor's plea that insufficient time was specified is not a valid reason for extension of time. If the Engineer finds that the work was delayed because of conditions beyond the control and without the fault of the Contractor, he may recommend to the Owner that the contract time be extended as conditions justify. If the Owner extends the contract, the extended time for completion shall then be in full force and effect, the same as though it were the original time for completion.

SC.7 KNOWLEDGE OF CONDITIONS

The Contractor states that he has examined all the available records and has made a field examination of the site and right-of-way and that he has informed himself about the character, quality, and quantity of surface and subsurface materials and other conditions to be encountered; the quantities in various sections of the work; the character of equipment and facilities needed for the prosecution of the work; the location and suitability of all construction materials; the local labor conditions; and all other matters in connection with the work and services to be performed under this contract.

SC.8 PERMITS AND RIGHTS-OF-WAY

The Owner will secure easements across public or private property permanently required for the pipelines at no cost to the Contractor.

The Contractor shall lease, buy, or otherwise make satisfactory provision, without obligating the Owner in any manner, for any land required outside the land provided by the Owner.

State Highway and Railroad Crossing Permits will be secured by the Owner. All other permits and

licenses necessary for the prosecution of the work shall be secured and paid for by the Contractor.

SC.9 REFERENCE SPECIFICATIONS

Where reference is made in these Specifications to the Standard Specifications of the Arkansas State Highway and Transportation Department, such reference is made for expediency and standardization, and such specifications (latest edition thereof) referred to are hereby made a part of these Specifications.

More specifically, if any items or materials required for completion of the work required for this project are not specified in these Contract Documents, such items or materials and requirements for installation shall conform to the latest edition of the Arkansas State Highway and Transportation Department Standard Specifications for Highway Construction.

SC.10 PUBLIC UTILITIES AND OTHER PROPERTY TO BE CHANGED

In case it is necessary to change or move the property of any owner or of a public utility, such property shall not be moved or interfered with until ordered to do so by the Engineer. The right is reserved to the owner of public utilities to enter upon the limits of the project for the purpose of making such changes or repairs of their property that may be made necessary by performance of this Contract.

SC.11 USED MATERIALS

No material which has been used by the Contractor for any temporary purpose whatever is to be incorporated in the permanent structure without written consent of the Engineer.

SC.12 EXISTING STRUCTURES

The Plans show the locations of all known surface and subsurface structures. However, the Owner assumes no responsibility for failure to show any or all of these structures on the Plans, or to show them in their exact location. It is mutually agreed that such failure shall not be considered sufficient basis for claims for additional compensation for extra work or for increasing the pay quantities in any manner whatsoever, unless the obstruction encountered is such as to necessitate changes in the lines or grades, or requires the building of special work, provisions for which are not made in the Plans and Proposal, in which case the provisions in these Specifications for Extra Work shall apply.

The Contractor shall be responsible for protection of all existing structures, and any damage caused by his operations shall be repaired immediately without cost to the Owner. It shall be the responsibility of the prospective Contractor to examine the site completely before submitting his bid.

SC.13 USE OF EXPLOSIVES

Any use of explosives or blasting shall be as outlined in these Specifications.

SC.14 BARRICADES, LIGHTS, AND WATCHMEN

Where the work is performed on or adjacent to any street, alley, or public place, the Contractor shall, at his own expense, furnish and erect such barricades, fences, lights, and danger signals, shall provide such watchmen, and shall provide such other precautionary measures for the protection of persons or property and of the work as are necessary.

Barricades shall be painted in a color that will be visible at night. From sunset to sunrise the Contractor shall furnish and maintain at least one light at each barricade and a sufficient number of barricades shall be erected to keep vehicles from being driven on or into any work under construction. The Contractor shall furnish watchmen in sufficient numbers to protect the work.

The Contractor will be held responsible for all damage to the work due to failure to provide barricades, signs, lights, and watchmen to protect it. Whenever evidence is found of such damage, the Engineer may order the damaged portion immediately removed and replaced by the Contractor at his expense. The Contractor's responsibility for the maintenance of barricades, signs, and lights, and for providing watchmen, shall not cease until the project shall have been accepted by the Owner.

SC.15 FENCES AND DRAINAGE CHANNELS

Boundary fences or other improvements removed to permit the installation of the work shall be replaced in the same location and left in a condition as good or better than that in which they were found except as indicated on the Drawings.

Where surface drainage channels are disturbed or blocked during construction, they shall be restored to their original condition of grade and cross section after the work of construction is completed.

SC.16 WATER FOR CONSTRUCTION

Water used for the mixing of concrete, testing, or any other purpose incidental to this project, shall be furnished by the Contractor. The Contractor shall make the necessary arrangements for securing and transporting such water and shall take such water in a manner and at such times that will not produce a harmful drain or decrease of pressure in the Owners' water system. No separate payment will be made for water used but the cost thereof shall be included in the Unit Price Schedule.

SC.17 MATERIAL STORAGE

Materials delivered to the site of the work in advance of their use shall be stored so as to cause the least inconvenience and in a manner satisfactory to the Engineer.

SC.18 EXISTING UTILITIES AND SERVICE LINES

The Contractor shall be responsible for the protection of all existing utilities or improvements crossed by or adjacent to his construction operations. Where existing utilities or service lines are cut, broken, or damaged, the Contractor shall replace or repair immediately the utilities or service lines with the

same type of original material and construction or better, at his own expense.

SC.19 TESTING, INSPECTION AND CONTROL

Testing and control of all materials used in the work shall be done by an approved commercial laboratory employed and paid directly by the Contractor. The Contractor shall furnish, at this own expense, all necessary specimens for testing of the materials, as required by the Engineer.

SC.20 BOND

Coincident with the execution of the Contract, the Contractor shall furnish a good and sufficient surety bond, in the full amount of the Contract sum, guaranteeing the faithful performance of all covenants, stipulations, and agreements of the Contract, the payment of all bills and obligations arising from the execution of the Contract, (which bills or obligations might or will in any manner become a claim against the Owner), and guaranteeing the work included in this Contract against faulty materials and/or poor workmanship for one (1) year after the date of completion of Contract.

All provisions of the bond shall be complete and in full accordance with Statutory requirements. The bond shall be executed with the proper sureties through a company licensed and qualified to operate in the state and approved by the Owner. The issuing agent's power of attorney shall be attached to the bond and the bond shall be signed by an agent resident in the state and date of bond shall be the date of execution of the Contract. If at any time during the continuance of the Contract the surety on the Contractor's bond becomes irresponsible, the Owner shall have the right to require additional and sufficient sureties which the Contractor shall furnish to the satisfaction of the Owner within ten (10) days after notice to do so. In default thereof, the Contract may be suspended and all payments or money due the Contractor withheld.

SC.21 LIGHT AND POWER

The Contractor shall provide, at his own expense, temporary lighting and facilities required for the proper prosecution and inspection of the work. At the time the Owner obtains beneficial occupancy of any of the facilities placed in satisfactory service, charges for power and light for regular operation of those involved facilities will become the responsibility of the Owner.

SC.22 LINES AND GRADES

The Contractor will be furnished baselines and benchmarks to control the work. The Contractor shall be responsible for the additional instrument control necessary to layout and construct the improvements. The Contractor's instrument control of the work shall not be measured for separate payment.

As a minimum, the Contractor shall provide the following instrument control for the work:

- a. For the full length and width of all areas within the limits of paving, the finished grade of the concrete surface course shall be controlled by grade wires or forms set by the Contractor to

control the final surface, in accordance with the plans.

- b. For the full length and width of all areas within the limits of paving, the initial courses of bituminous pavement will be controlled by uniform thickness. The course under the final surface course shall be controlled by grade wire, and the final surface course shall be controlled by uniform thickness. The bituminous pavement shall be constructed with a lay down machine with automatic controls and a forty (40) foot ski.
- c. For the full length and width of all areas within the limits of paving, the crushed aggregate base course and the sub base course will be controlled with intermediate and final surface stakes, "blue tops". Stakes shall be set as required or as directed by the Engineer to control the construction.
- d. The Contractor shall set intermediate line and grade stakes and final grade stakes, "blue tops," as required to control the construction of shoulders.

SC.23 LEGAL HOLIDAYS

January 1, Martin Luther King, Jr. Day, President's Day, Memorial Day, July 4, Labor Day, Veteran's Day, Thanksgiving, Day after Thanksgiving, December 24, and December 25 will be considered as being legal holidays; no other days will be so considered. Should any holiday fall on Sunday, the holiday shall be observed on the following Monday. No engineering observation will be furnished on legal holidays or Sundays, except in an emergency. The Contractor shall observe the legal holidays and Sundays, and no work shall be performed on these days except in an emergency. However, these days shall not be excluded from Contract time.

SC.24 SEQUENCE OF CONSTRUCTION

Sequence of all phases of work shall be such as to provide for the least possible inconvenience to the Owner. Scheduling of work which would interfere with normal traffic operation shall be coordinated with the Owner. Material and equipment received on the project prior to time of installation shall be stored at such locations designated by the Owner.

The Contractor shall furnish a proposed work schedule to the Engineer for review and approval as soon as possible after award of the Contract. This schedule shall show anticipated equipment delivery schedules and times of beginning and completing of the several work tasks.

SC.25 TEST BORINGS

The Contractor may rely upon the general accuracy of the test pit or soil boring data contained in reports or drawings, but such reports and drawings are not Contract Documents. The Contractor may not rely upon or make any claim against Owner, Engineer, or Engineer's Consultants with respect to (1) the completeness of such reports and drawings for Contractor's purposes, including, but not limited to, any aspects of the means, methods, techniques, sequences, and procedures of construction to be employed by the Contractor and safety precautions and programs incident thereto, (2) other data,

interpretations, opinions, and information contained in such reports or shown or indicated in such drawings, (3) any Contractor interpretation of or conclusion drawn from any data, interpretations, opinions, or information.

SC.26 TEMPORARY FIELD OFFICE

Not required for this project.

SC.27 RELEASE AND CONTRACTOR'S AFFIDAVIT

At the project's completion, the Contractor shall execute the attached Release and Lien Waiver to release all claims against the Owner arising under and by virtue of his Contract. The date of the Release shall be that agreed to for the final acceptance of the project with the Owner.

SC.28 MAINTENANCE BOND

The Contractor shall execute the attached Maintenance Bond guaranteeing the work included in the Contract against faulty materials and/or prior workmanship for one year after completion of the Contract. The date of the Maintenance Bond shall be that agreed to for the final acceptance of the project with the Owner. The Maintenance Bond shall be for 100% of the final contract amount.

At the end of the applicable maintenance period, the Owner and/or the Engineer, with the Contractor, shall make an inspection of the work. The Contractor immediately shall repair and correct any and all defects which have resulted from faulty workmanship, equipment, or materials, following which repair and correction the Local Public Agency will accept full maintenance of the work.

RELEASE

FROM: Contractor's Name _____

Address _____

TO: City of Jonesboro

DATE OF CONTRACT: _____

Upon receipt of the final payment and in consideration of that amount, the undersigned does hereby release the Owner and its agents from any and all claims arising under or by virtue of this Contract or modification thereof occurring from the undersigned's performance in connection with the construction of the

Dalton-Farmer Sanitary Sewer Extension Project

Contractor's Signature

Title

Subscribed and sworn to before me this _____ day of _____, 20____.

Notary Public

My Commission Expires:

CONTRACTOR'S AFFIDAVIT

FROM: Contractor's Name _____

Address _____

TO: City of Jonesboro

DATE OF CONTRACT: _____

I hereby certify that all claims for material, labor, and supplies entered into contingent and incident to the construction or used in the course of the performance of the work on the construction of the

Dalton-Farmer Sanitary Sewer Extension Project

have been fully satisfied.

Contractor's Signature

Title

Subscribed and sworn to before me this ____ day of _____, 20__.

Notary Public

My Commission Expires:

The Surety Company consents to the release of the retained percentage on this project with the understanding that should any unforeseen contingencies arise having a right of action on the bond that the Surety Company will not waive liability through the consent to the release of the retained percentage.

Dated _____

Surety Company

By _____
Resident Agent, State of Arkansas

MAINTENANCE BOND

KNOW ALL MEN BY THESE PRESENTS:

That we, _____,

as Principal, and _____,

as Surety, are held and firmly bound unto the City of Jonesboro, as Obligee, in the full and

just sum of _____
(\$ _____) DOLLARS, lawful money of the United States of America, to be paid to the said Obligee, its successors or assigns, for the payment of which, well and truly to be made, we and each of us, bind ourselves, our heirs, executors and assigns, themselves, and their successors and assigns, jointly and severally, firmly by these presents.

Dated this _____ day of _____, 20_____.

The conditions of this obligation are such, that whereas, said Principal, has by a certain contract with the City of Jonesboro dated the ____ day of _____, 20 ____, agreed to construct the Dalton-Farmer Drive Sanitary Sewer Extension and to maintain the said Improvement in good condition for a period of one (1) year from the date of acceptance of the improvements.

NOW, THEREFORE, THE CONDITION OF THIS OBLIGATION IS SUCH, that if the said Principal shall indemnify and hold harmless the said Obligee from and against all loss, costs, damages, and expenses whatsoever which it may suffer or be compelled to pay by reason of failure of the said Principal to keep said work in repair for a one year period beginning _____ against any and all defects of faulty workmanship or inferior material, then this obligation shall be void; otherwise to remain in full force and effect.

It is further agreed that if the said Principal or Surety herein shall fail to maintain said improvements in good condition for the said period of 1 year, and at any time repairs shall be necessary, that the cost of making said repairs shall be determined by the Owner, or some person or persons designated by the Owner to ascertain the same, and if, upon thirty (30) days notice, the said amount ascertained shall not be paid by the Principal or Surety herein, or if the necessary repairs are not made, that said amount shall become due upon the expiration of thirty (30) days, and suit may be maintained to recover the amount so determined in any Court of competent jurisdiction; and that the amount so determined shall be conclusive upon the parties as to the amount due on this bond for the repair or repairs included therein; and that the cost of all repairs shall be so determined from time to time during the life of this bond, as the condition of the improvements may require.

Signed, sealed and delivered the day and year first above written.

Principal

ATTEST:

BY: _____

SEAL

Surety

ATTEST:

BY: _____

Attorney in Fact

XVIII. TECHNICAL SPECIFICATIONS

TABLE OF CONTENTS

TITLE

SP-1	EDA Contracting Provisions for Construction Projects
SP-2	CWL Installation – Sewer Main
SP-3	CWL Specifications Water and Sewer Construction
SP-4	CWL – Safety Rules for All Contractors’ Employees on All City Water & Light Projects
SP-5	Statements and Payrolls

**U. S. DEPARTMENT OF COMMERCE
ECONOMIC DEVELOPMENT ADMINISTRATION**



**EDA CONTRACTING PROVISIONS
FOR CONSTRUCTION PROJECTS**

These EDA Contracting Provisions for Construction Projects (EDA Contracting Provisions) are intended for use by recipients receiving federal assistance from the U. S. Department of Commerce - Economic Development Administration (EDA). They contain provisions specific to EDA and other federal provisions not normally found in non-federal contract documents. The requirements contained herein must be incorporated into all construction contracts and subcontracts funded wholly or in part with federal assistance from EDA.

TABLE OF CONTENTS

1. Definitions
2. Applicability
3. Federally Required Contract Provisions
4. Required Provisions Deemed Inserted
5. Inspection by EDA Representatives
6. Examination and Retention of Contractor's Records
7. Construction Schedule and Periodic Estimates
8. Contractor's Title to Material
9. Inspection and Testing of Materials
10. "OR EQUAL" Clause
11. Patent Fees and Royalties
12. Claims for Extra Costs
13. Contractor's and Subcontractor's Insurance
14. Contract Security Bonds
15. Labor Standards - Davis-Bacon and Related Acts
16. Labor Standards - Contract Work Hours and Safety Standards Act
17. Equal Employment Opportunity
18. Contracting with Small, Minority and Women's Businesses
19. Health, Safety and Accident Prevention
20. Conflict of Interest and Other Prohibited Interests
21. New Restrictions on Lobbying
22. Historical and Archaeological Data Preservation
23. Clean Air and Water
24. Use of Lead-Based Paints on Residential Structures
25. Energy Efficiency
26. Environmental Requirements
27. Debarment, Suspension, Ineligibility and Voluntary Exclusions
28. EDA Project Sign

1. DEFINITIONS

Agreement – The written instrument that is evidence of the agreement between the Owner and the Contractor overseeing the Work.

Architect/Engineer - The person or other entity engaged by the Recipient to perform architectural, engineering, design, and other services related to the work as provided for in the contract.

Contract – The entire and integrated written agreement between the Owner and the Contractor concerning the Work. The Contract supersedes prior negotiations, representations, or agreements, whether written or oral.

Contract Documents – Those items so designated in the Agreement. Only printed or hard copies of the items listed in the Agreement are Contract Documents.

Contractor – The individual or entity with whom the Owner has entered into the Agreement.

Drawings or Plans – That part of the Contract Documents prepared or approved by the Architect/Engineer that graphically shows the scope, extent, and character of the Work to be performed by the Contractor.

EDA - The United States of America acting through the Economic Development Administration of the U.S. Department of Commerce or any other person designated to act on its behalf. EDA has agreed to provide financial assistance to the Owner, which includes assistance in financing the Work to be performed under this Contract. Notwithstanding EDA's role, nothing in this Contract shall be construed to create any contractual relationship between the Contractor and EDA.

Owner – The individual or entity with whom the Contractor has entered into the Agreement and for whom the Work is to be performed.

Project – The total construction of which the Work to be performed under the Contract Documents may be the whole, or a part.

Recipient - An entity receiving Federal financial assistance from EDA, including any EDA-approved successor to the entity.

Specifications – That part of the Contract Documents consisting of written requirements for materials, equipment, systems, standards, and workmanship as applied to the Work, and certain administrative requirements and procedural matters applicable thereto.

Subcontractor – An individual or entity having direct contract with the Contractor or with any other Subcontractor for the performance of a part of the Work at the Site.

Work – The entire construction or the various separately identifiable parts thereof required to be provided under the Contract Documents. Work includes and is the result of performing or providing all labor, services, and documentation necessary to produce such construction and furnishing, installing, and incorporating all materials and equipment into such construction, all as required by the Contract Documents.

2. **APPLICABILITY**

The Project to which the construction work covered by this Contract pertains is being assisted by the United States of America through federal assistance provided by the U.S. Department of Commerce - Economic Development Administration (EDA). Neither EDA, nor any of its departments, entities, or employees is a party to this Contract. The following EDA Contracting Provisions are included in this Contract and all subcontracts or related instruments pursuant to the provisions applicable to such federal assistance from EDA.

3. **FEDERALLY REQUIRED CONTRACT PROVISIONS**

- (a) Administrative, contractual, or legal remedies in instances where contractors violate or breach contract terms, and provide for such sanctions and penalties as may be appropriate (Contracts more than the simplified acquisition threshold - currently fixed at \$100,000. *See* 41 U.S.C. 403(11)).
- (b) Termination for cause and for convenience by the Recipient including the manner by which it will be effected and the basis for settlement (all contracts in excess of \$10,000).
- (c) Compliance with Executive Order 11246 of September 24, 1965, *Equal Employment Opportunity*, as amended by Executive Order 11375 of October 13, 1967 and as supplemented by Department of Labor regulations at 41 C.F.R. chapter 60 (applicable to all construction contracts awarded in excess of \$10,000 by recipients of federal assistance and their contractors or subrecipients).
- (d) Compliance with the Copeland "Anti-Kickback" Act (18 U.S.C. § 874) as supplemented by Department of Labor regulations at 29 C.F.R. part 3 (all contracts and subgrants for construction or repair).
- (e) Compliance with the Davis-Bacon Act (40 U.S.C. § 3145) as supplemented by Department of Labor regulations at 29 C.F.R. part 5 (construction contracts in excess of \$2,000 awarded by Recipients and subrecipients).
- (f) Compliance with sections 103 and 107 of the Contract Work Hours and Safety Standards Act (40 U.S.C. §§ 327-330) as supplemented by Department of Labor regulations at 29 C.F.R. part 5. (construction contracts awarded by Recipients and subrecipients in excess of \$2,000, and in excess of \$2,500 for other contracts which involve the employment of mechanics or laborers)
- (g) EDA requirements and regulations pertaining to reporting.

(h) EDA requirements and regulations pertaining to patent rights with respect to any discovery or invention which arises or is developed in the course of or under such contract.

(i) EDA requirements and regulations pertaining to copyrights and rights in data.

(j) Compliance with all applicable standards, orders, or requirements issued under section 306 of the Clear Air Act (42 U.S.C. § 7606), section 508 of the Clean Water Act (33 U.S.C. § 1368), Executive Order 11738, *Providing for Administration of the Clean Air Act and the Federal Water Pollution Control Act With Respect to Federal Contracts, Grants, or Loans*, and Environmental Protection Agency regulations at 48 C.F.R. part 15 (applicable to contracts, subcontracts, and subgrants of amounts in excess of \$ 100,000).

4. **REQUIRED PROVISIONS DEEMED INSERTED**

Each and every provision of law and clause required by law to be inserted in this contract shall be deemed to be inserted herein and the contract shall be read and enforced as though it were included herein, and if through mistake or otherwise any such provision is not inserted, or is not correctly inserted, then upon the application of either party the contract shall forthwith be physically amended to make such insertion of correction.

5. **INSPECTION BY EDA REPRESENTATIVES**

The authorized representatives and agents of EDA shall be permitted to inspect all work, materials, payrolls, personnel records, invoices of materials, and other relevant data and records.

6. **EXAMINATION AND RETENTION OF CONTRACTOR'S RECORDS**

(a) The Owner, EDA, or the Comptroller General of the United States, or any of their duly authorized representatives shall, generally until three years after final payment under this contract, have access to and the right to examine any of the Contractor's directly pertinent books, documents, papers, or other records involving transactions related to this contract for the purpose of making audit, examination, excerpts, and transcriptions.

(b) The Contractor agrees to include in first-tier subcontracts under this contract a clause substantially the same as paragraph (a) above. "Subcontract," as used in this clause, excludes purchase orders that do not exceed \$10,000.

(c) The periods of access and examination in paragraphs (a) and (b) above for records relating to (1) appeals under the disputes clause of this contract, (2) litigation or settlement of claims arising from the performance of this contract, or (3) costs and expenses of this contract to which the Owner, EDA, or Comptroller General or any of their duly authorized representatives has taken exception shall continue until disposition of such appeals, litigation, claims, or exceptions.

7. **CONSTRUCTION SCHEDULE AND PERIODIC ESTIMATES**

Immediately after execution and delivery of the contract, and before the first partial payment is made, the Contractor shall deliver to the Owner an estimated construction progress schedule in a form satisfactory to the Owner, showing the proposed dates of commencement and completion of each of the various subdivisions of work required under the Contract Documents and the anticipated amount of each monthly payment that will become due to the Contractor in accordance with the progress schedule. The Contractor also shall furnish the Owner (a) a detailed estimate giving a complete breakdown of the contract price and (b) periodic itemized estimates of work done for the purpose of making partial payments thereon. The costs employed in making up any of these schedules will be used only to determine the basis of partial payments and will not be considered as fixing a basis for additions to or deductions from the contract price.

8. **CONTRACTOR'S TITLE TO MATERIAL**

No materials, supplies, or equipment for the work shall be purchased by the Contractor or by any subcontractor that is subject to any chattel mortgage or under a conditional sale contract or other agreement by which an interest is retained by the seller. The Contractor warrants and guarantees that he/she has good title to all work, materials, and equipment used by him/her in the Work, free and clear of all liens, claims, or encumbrances.

9. **INSPECTION AND TESTING OF MATERIALS**

All materials and equipment used in the completion of the Work shall be subject to adequate inspection and testing in accordance with accepted standards. The laboratory or inspection agency shall be selected by the Owner. Materials of construction, particularly those upon which the strength and durability of any structure may depend, shall be subject to inspection and testing to establish conformance with specifications and suitability for intended uses.

10. **"OR EQUAL" CLAUSE**

Whenever a material, article, or piece of equipment is identified in the Contract Documents by reference to manufacturers' or vendors' names, trade names, catalogue numbers, etc., it is intended merely to establish a standard. Any material, article, or equipment of other manufacturers and vendors that will perform adequately the duties imposed by the general design will be considered equally acceptable provided the material, article, or equipment so proposed is, in the opinion of the Architect/Engineer, of equal substance and function. However, such substitution material, article, or equipment shall not be purchased or installed by the Contractor without the Architect/Engineer's written approval.

11. **PATENT FEES AND ROYALTIES**

(a) Contractor shall pay all license fees and royalties and assume all costs incident to the use in the performance of the Work or the incorporation in the Work of any invention, design, process, product, or device that is the subject of patent rights or copyrights held by others. If a particular invention, design, process, product, or device is specified in the Contract Documents for use in

the performance of the Work and if, to the actual knowledge of Owner or Engineer, its use is subject to patent rights or copyrights calling for the payment of any license fee or royalty to others, the existence of such rights shall be disclosed by the Owner in the Contract Documents.

(b) To the fullest extent permitted by Laws and Regulations, the Contractor shall indemnify and hold harmless the Owner and the Architect/Engineer, and the officers, directors, partners, employees, agents, consultants, and subcontractors of each and any of them from and against all claims, costs, losses, and damages (including but not limited to all fees and charges of engineers, architects, attorneys, and other professionals and all court or arbitration or other dispute resolution costs) arising out of or relating to any infringement of patent rights or copyrights incident to the use in the performance of the Work or resulting from the incorporation in the Work of any invention, design, process, product, or device not specified in the Contract Documents.

12. CLAIMS FOR EXTRA COSTS

No claims for extra work or cost shall be allowed unless the same was done in pursuance of a written order from the Architect/Engineer approved by the Owner.

13. CONTRACTORS AND SUBCONTRACTORS INSURANCE

(a) The Contractor shall not commence work under this Contract until the Contractor has obtained all insurance reasonably required by the Owner, nor shall the Contractor allow any subcontractor to commence work on his/her subcontract until the insurance required of the subcontractor has been so obtained and approved.

(b) Types of insurance normally required are:

- (1) Workmen's Compensation
- (2) Contractor's Public Liability and Property Damage
- (3) Contractor's Vehicle Liability
- (4) Subcontractors Public Liability, Property Damage and Vehicle Liability
- (5) Builder's Risk (Fire and Extended Coverage)

(c) **Scope of Insurance and Special Hazards:** The insurance obtained, which is described above, shall provide adequate protection for the Contractor and his/her subcontractors, respectively, against damage claims that may arise from operations under this contract, whether such operations be by the insured or by anyone directly or indirectly employed by him/her and also against any of the special hazards that may be encountered in the performance of this Contract.

(d) **Proof of Carriage of Insurance:** The Contractor shall furnish the Owner with certificates showing the type, amount, class of operations covered, effective dates, and dates of expiration of applicable insurance policies.

14. **CONTRACT SECURITY BONDS**

(a) If the amount of this Contract exceeds \$100,000, the Contractor shall furnish a performance bond in an amount at least equal to one hundred percent (100%) of the Contract price as security for the faithful performance of this Contract and also a payment bond in an amount equal to one hundred percent (100%) of the Contract price or in a penal sum not less than that prescribed by State, Territorial, or local law, as security for the payment of all persons performing labor on the Work under this Contract and furnishing materials in connection with this Contract. The performance bond and the payment bond may be in one or in separate instruments in accordance with local law. Before final acceptance, each bond must be approved by EDA. If the amount of this Contract does not exceed \$100,000, the Owner shall specify the amount of the payment and performance bonds.

(b) All bonds shall be in the form prescribed by the Contract Documents except as otherwise provided in applicable laws or regulations, and shall be executed by such sureties as are named in the current list of *Companies Holding Certificates of Authority as Acceptable Sureties on Federal Bonds and as Acceptable Reinsuring Companies* as published in Treasury Circular 570 (amended) by the Financial Management Service, Surety Bond Branch, U.S. Department of the Treasury. All bonds signed by an agent must be accompanied by a certified copy of the agent's authority to act. Surety companies executing the bonds must also be authorized to transact business in the state where the Work is located.

15. **LABOR STANDARDS - DAVIS-BACON AND RELATED ACTS**
(as required by section 601 of PWEDA)

(a) **Minimum Wages**

(1) All laborers and mechanics employed or working upon the site of the Work in the construction or development of the Project will be paid unconditionally and not less often than once a week, and without subsequent deduction or rebate on any account (except such payroll deductions as are permitted by regulations issued by the Secretary of Labor under the Copeland Act at 29 C.F.R. part 3, the full amount of wages and bona fide fringe benefits (or cash equivalents thereof) due at the time of payment computed at rates not less than those contained in the wage determination of the Secretary of Labor, which is attached hereto and made a part hereof, regardless of any contractual relationship that may be alleged to exist between the Contractor and such laborers and mechanics. Contributions made or costs reasonably anticipated for bona fide fringe benefits under Section 1(b)(2) of the Davis-Bacon Act on behalf of laborers or mechanics are considered wages paid to such laborers or mechanics, subject to the provisions of 29 C.F.R. § 5.5(a)(1)(iv); also, regular contributions made or costs incurred for more than a weekly period (but not less often than quarterly) under plans, funds, or programs, which cover the particular weekly period, are deemed to be constructively made or incurred during such weekly period. Such laborers and mechanics shall be paid the appropriate wage rate and fringe benefits on the wage determination for the classification of work actually performed, without regard to skill, except as provided in 29 C.F.R. § 5.5(a)(4). Laborers or mechanics performing work in more than one classification may be compensated at the

rate specified for each classification for the time actually worked therein, provided that the employer's payroll records accurately set forth the time spent in each classification in which work is performed. The wage determination (including any additional classification and wage rates determined under 29 C.F.R. § 5.5(a)(1)(ii) and the Davis-Bacon poster (WH-1321) shall be posted at all times by the contractor and its subcontractors at the site of the work in a prominent and accessible place where it can be easily seen by the workers.

(2) (i) Any class of laborers or mechanics to be employed under the Contract, but not listed in the wage determination, shall be classified in conformance with the wage determination. EDA shall approve an additional classification and wage rate and fringe benefits therefore only when the following criteria have been met:

(A) The work to be performed by the classification requested is not performed by a classification in the wage determination;

(B) The classification is utilized in the area by the construction industry; and

(C) The proposed wage rate, including any bona fide fringe benefits, bears a reasonable relationship to the wage rates contained in the wage determination.

(ii) If the Contractor and the laborers and mechanics to be employed in the classification (if known), or their representatives, and EDA or its designee agree on the classification and wage rate (including the amount designated for fringe benefits where appropriate), a report of the action taken shall be sent by EDA or its designee to the Administrator of the Wage and Hour Division, Employment Standards Administration, U.S. Department of Labor, Washington, D.C. 20210.

(iii) In the event the Contractor, the laborers or mechanics to be employed in the classification or their representatives, and EDA or its designee do not agree on the proposed classification and wage rate (including the amount designated for fringe benefits, where appropriate), EDA or its designee shall refer the questions, including the views of all interested parties and the recommendation of EDA or its designee, to the Administrator for determination.

(iv) The wage rate (including fringe benefits where appropriate) determined pursuant to paragraphs (a)(2)(ii) or (iii) of this section, shall be paid to all workers performing work in the classification under this contract from the first day on which work is performed in the classification.

(3) Whenever the minimum wage rate prescribed in the contract for a class of laborers or mechanics includes a fringe benefit which is not expressed as an hourly rate, the Contractor shall either pay the benefit as stated in the wage determination or shall pay another bona fide fringe benefit or an hourly cash equivalent thereof.

(4) If the Contractor does not make payments to a trustee or other third person, the Contractor may consider as part of the wages of any laborer or mechanic the amount of any costs reasonably anticipated in providing bona fide fringe benefits under a plan or program, provided, that the Secretary of Labor has found, upon the written request of the Contractor, that the applicable standards of the Davis-Bacon Act have been met. The Secretary of Labor may require the Contractor to set aside in a separate account assets for the meeting of obligations under the plan or program.

(b) Withholding

EDA or its designee shall upon its own action or upon written request of an authorized representative of the Department of Labor withhold or cause to be withheld from the Contractor under this Contract or any other federal contract with the same prime Contractor, or any other federally-assisted contract subject to Davis-Bacon prevailing wage requirements, which is held by the same prime contractor so much of the accrued payments or advances as may be considered necessary to pay laborers and mechanics, including apprentices, trainees and helpers, employed by the Contractor or any subcontractor the full amount of wages required by the Contract. In the event of failure to pay any laborer or mechanic, including any apprentice, trainee or helper employed or working on the site of the Work in the construction or development of the Project, all or part of the wages required by the Contract, EDA or its designee may, after written notice to the Contractor, sponsor, applicant, or owner, take such action as may be necessary to cause the suspension of any further payment, advance, or guarantee of funds until such violations have ceased. EDA or its designee may, after written notice to the Contractor, disburse such amounts withheld for and on account of the Contractor or subcontractor to the respective employees to whom they are due. The Comptroller General shall make such disbursements in the case of direct Davis-Bacon Act contracts.

(c) Payrolls and basic records

(1) Payrolls and basic records relating thereto shall be maintained by the Contractor during the course of the Work and preserved for a period of three years thereafter for all laborers and mechanics working at the site of the Work in the construction or development of the Project. Such records shall contain the name, address, and social security number of each such worker, his or her correct classification, hourly rates of wages paid (including rates of contributions or costs anticipated for bona fide fringe benefits or cash equivalents thereof of the types described in section 1(b) (2) (B) of the Davis-Bacon Act), daily and weekly number of hours worked, deductions made and actual wages paid. Whenever the Secretary of Labor has found under 29 C.F.R. § 5.5(a)(1)(iv) that the wages of any laborer or mechanic include the amount of any costs reasonably anticipated in providing benefits under a plan or program described in section 1(b)(2)(B) of the Davis-Bacon Act, the Contractor shall maintain records which show that the commitment to provide such benefits is enforceable, the plan or program is financially responsible, and the plan or program has been communicated in writing to the laborers or mechanics affected, and provide records that show the costs anticipated or the actual cost incurred in providing such benefits. Contractors employing apprentices or trainees under approved programs shall maintain written evidence of the registration of

apprenticeship programs and certification of trainee programs, the registration of the apprentices and trainees, and the ratios and wage rates prescribed in the applicable programs.

(2) (i) For each week in which Contract work is performed, the Contractor shall submit a copy of all payrolls to the Owner for transmission to EDA or its designee. The payrolls submitted shall set out accurately and completely all of the information required to be maintained under 29 C.F.R. part 5.5(a)(3)(i). This information may be submitted in any form desired. Optional Form WH-347 is available for this purpose. It may be purchased from the Superintendent of Documents (Federal Stock Number 029-005-00014-1), U.S. Government Printing Office, Washington, D.C. 20402; or downloaded from the U.S. Department of Labor's website at www.dol.gov/esa/forms/whd/index.htm. The prime Contractor is responsible for the submission of copies of payrolls by all subcontractors

(ii) Each payroll submitted shall be accompanied by a "Statement of Compliance," signed by the Contractor or subcontractor or his or her agent who pays or supervises the payment of the persons employed under the Contract and shall certify the following:

(A) That the payroll for the payroll period contains the information required to be maintained under 29 C.F.R. § 5.5(a)(3)(i) and that such information is correct and complete;

(B) That each laborer or mechanic (including each helper, apprentice, and trainee) employed on the Contract during the payroll period has been paid the full weekly wages earned, without rebate, either directly or indirectly, and that no deductions have been made either directly or indirectly from the full wages earned, other than permissible deductions as set forth in 29 C.F.R. part 3;

(C) That each laborer or mechanic has been paid not less than the applicable wage rates and fringe benefits or cash equivalents for the classification of work performed, as specified in the applicable wage determination incorporated into the Contract.

(iii) The weekly submission of a properly executed certification set forth on the reverse side of Optional Form WH-347 shall satisfy the requirement for submission of the "Statement of Compliance" required by paragraph 14(c)(ii) of this section.

(iv) The falsification of any of the above certifications may subject the Contractor or subcontractor to civil or criminal prosecution under section 1001 of Title 18 and section 231 of Title 31 of the U.S. Code.

(3) The Contractor or subcontractor shall make the records required under paragraph 14(c)(1) of this section available for inspection, copying, or transcription by authorized representatives of EDA or its designee or the Department of Labor, and shall permit such representatives to interview employees during working hours on the job. If the Contractor or subcontractor fails to submit the required records or to make them

available, EDA or its designee may, after written notice to the Contractor or Owner, take such action as may be necessary to cause the suspension of any further payment, advance, or guarantee of funds. Furthermore, failure to submit the required records upon request or to make such records available may be grounds for debarment action pursuant to 29 C.F.R. part 5.12.

(d) Apprentices and Trainees.

(1) **Apprentices.** Apprentices will be permitted to work at less than the predetermined rate for the work they performed when they are employed pursuant to and individually registered in a bona fide apprenticeship program registered with the U.S. Department of Labor, Employment and Training Administration, Bureau of Apprenticeship and Training, or with a State Apprenticeship Agency recognized by the Bureau, or if a person is employed in his or her first 90 days of probationary employment as an apprentice in such an apprenticeship program, who is not individually registered in the program, but who has been certified by the Bureau of Apprenticeship and Training or a State Apprenticeship Agency (where appropriate) to be eligible for probationary employment as an apprentice. The allowable ratio of apprentices to journeymen on the job site in any craft classification shall not be greater than the ratio permitted to the Contractor as to the entire work force under the registered program. Any worker listed on a payroll at an apprentice wage rate who is not registered or otherwise employed as stated above, shall be paid not less than the applicable wage rate on the wage determination for the classification of work actually performed. In addition, any apprentice performing work on the job site in excess of the ratio permitted under the registered program shall be paid not less than the applicable wage rate on the wage determination for the work actually performed. Where a Contractor is performing construction on a Project in a locality other than that in which its program is registered, the ratios and wage rates (expressed in percentages of the journeyman's hourly rate) specified in the Contractor's or subcontractor's registered program shall be observed. Every apprentice must be paid at not less than the rate specified in the registered program for the apprentice's level of progress, expressed as a percentage of the journeymen hourly rate specified in the applicable wage determination. Apprentices shall be paid fringe benefits in accordance with the provisions of the apprenticeship program. If the apprenticeship program does not specify fringe benefits, apprentices must be paid the full amount of fringe benefits listed on the wage determination for the applicable classification. If the Administrator determines that a different practice prevails for the applicable apprentice classification, fringes shall be paid in accordance with that determination. In the event the Bureau of Apprenticeship and Training, or a State Apprenticeship Agency recognized by the Bureau, withdraws approval of an apprenticeship program, the Contractor will no longer be permitted to utilize apprentices at less than the applicable predetermined rate for the work performed until an acceptable program is approved.

(2) **Trainees.** Except as provided in 29 C.F.R. § 5.16, trainees will not be permitted to work at less than the predetermined rate for the work performed unless they are employed pursuant to and individually registered in a program that has received prior approval, evidenced by formal certification by the U.S. Department of Labor, Employment and

Training Administration. The ratio of trainees to journeymen on the job site shall not be greater than permitted under the plan approved by the Employment and Training Administration. Every trainee must be paid at not less than the rate specified in the approved program for the trainee's level of progress, expressed as a percentage of the journeyman's hourly rate specified in the applicable wage determination. Trainees shall be paid fringe benefits in accordance with the provisions of the trainee program. If the trainee program does not mention fringe benefits, trainees shall be paid the full amount of fringe benefits listed on the wage determination unless the Administrator of the Wage and Hour Division determines that there is an apprenticeship program associated with the corresponding journeyman wage rate on the wage determination which provides for less than full fringe benefits for apprentices. Any employee listed on the payroll at a trainee rate who is not registered and participating in a training plan approved by the Employment and Training Administration shall be paid not less than the applicable wage rate on the wage determination for the classification of work actually performed. In addition, any trainee performing work on the job site in excess of the ratio permitted under the registered program shall be paid not less than the applicable wage rate on the wage determination for the work actually performed. In the event the Employment and Training Administration withdraws approval of a training program, the Contractor will no longer be permitted to utilize trainees at less than the applicable predetermined rate for the work performed until an acceptable program is approved.

(3) **Equal employment opportunity.** The utilization of apprentices, trainees and journeymen under this part shall be in conformity with the equal employment opportunity requirements of Executive Order 11246, *Equal Employment Opportunity*, as amended, and 29 C.F.R. part 30.

(e) **Compliance with Copeland Anti-Kickback Act Requirements.** The Contractor shall comply with the Copeland Anti-Kickback Act (18 U.S.C. § 874 and 40 U.S.C. § 276(c)) as supplemented by Department of Labor regulations (29 C.F.R. part 3, "Contractors and Subcontractors on Public Buildings or Public Works Financed in Whole or in Part by Loans or Grants of the United States"). The Act provides that the Contractor and any subcontractors shall be prohibited from inducing, by any means, any person employed in the construction, completion, or repair of public facilities, to give up any part of the compensation to which they are otherwise entitled. The Owner shall report all suspected or reported violations to EDA.

(f) **Subcontracts.** The Contractor and any subcontractors will insert in any subcontracts the clauses contained in 29 C.F.R. §§ 5.5(a)(1) through (10) and such other clauses as EDA or its designee may require, and also a clause requiring the subcontractors to include these clauses in any lower tier subcontracts. The prime Contractor shall be responsible for the compliance by any subcontractor or lower tier subcontractor with all the contract clauses in 29 C.F.R. part 5.5.

(g) **Contract termination; debarment.** The breach of the contract clauses in 29 C.F.R. part 5.5 may be grounds for termination of the contract, and for debarment as a Contractor and a subcontractor as provided in 29 C.F.R. § 5.12.

(h) **Compliance with Davis-Bacon and Related Act Requirements.** All rulings and interpretations of the Davis-Bacon and Related Acts contained in 29 C.F.R. parts 1, 3, and 5 are herein incorporated by reference in this contract.

(i) **Disputes concerning labor standards.** Disputes arising out of the labor standards provisions of this Contract shall not be subject to the general disputes clause of this Contract. Such disputes shall be resolved in accordance with the procedures of the Department of Labor set forth in 29 C.F.R. parts 5, 6, and 7. Disputes within the meaning of this clause include disputes between the contractor (or any of its subcontractors) and EDA or its designee, the U.S. Department of Labor, or the employees or their representatives.

(j) **Certification of Eligibility.**

(1) By entering into this Contract, the Contractor certifies that neither it nor any person or firm that has an interest in the Contractor's firm is a person or firm ineligible to be awarded Government contracts by virtue of section 3(a) of the Davis-Bacon Act or 29 C.F.R. § 5.12(a)(1).

(2) No part of this Contract shall be subcontracted to any person or firm ineligible for award of a Government contract by virtue of section 3(a) of the Davis-Bacon Act or 29 C.F.R. § 5.12(a)(1).

(3) The penalty for making false statements is prescribed in the U.S. Criminal Code, 18 U.S.C. § 1001.

16. **LABOR STANDARDS - CONTRACT WORK HOURS AND SAFETY STANDARDS ACT**

As used in this paragraph, the terms "laborers" and "mechanics" include watchmen and guards.

(a) **Overtime requirements.** No Contractor or subcontractor contracting for any part of the Contract work, which may require or involve the employment of laborers or mechanics, shall require or permit any such laborer or mechanic in any workweek in which that person is employed on such work to work in excess of forty hours in such workweek unless such laborer or mechanic receives compensation at a rate not less than one and one-half times the basic rate of pay for all hours worked in excess of forty hours in such workweek.

(b) **Violation; liability for unpaid wages, liquidated damages.** In the event of any violation of the clause set forth in paragraph (a) of this section, the Contractor and any subcontractor responsible therefore shall be liable for the unpaid wages. In addition, such Contractor and subcontractor shall be liable to the United States (in the case of work done under contract for the District of Columbia or a territory, to such District or to such territory), for liquidated damages. Such liquidated damages shall be computed with respect to each individual laborer or mechanic, including watchmen and guards, employed in violation of the clause set forth in paragraph (a) of this section, in the sum of \$10 for each calendar day on which such individual was required or

permitted to work in excess of the standard workweek of forty hours without payment of the overtime wages required by the clause set forth in paragraph (a) of this section.

(c) **Withholding for unpaid wages and liquidated damages.** EDA or its designee shall upon its own action or upon written request of an authorized representative of the Department of Labor withhold or cause to be withheld, from any monies payable on account of work performed by the Contractor or subcontractor under any such Contract or any other federal contract with the same prime Contractor, or any other federally-assisted contract subject to the Contract Work Hours and Safety Standards Act, which is held by the same prime Contractor such sums as may be determined to be necessary to satisfy any liabilities of such Contractor or subcontractor for unpaid wages and liquidated damages as provided in the clause set forth in paragraph (b) of this section.

(d) **Subcontracts.** The Contractor or subcontractor shall insert in any subcontracts the clauses set forth in paragraphs (a) through (c) of this section and also a clause requiring the subcontractors to include these clauses in any lower tier subcontracts. The prime Contractor shall be responsible for compliance by any subcontractor or lower tier subcontractor with the clauses set forth in paragraphs (a) through (c) of this section.

17. **EQUAL EMPLOYMENT OPPORTUNITY**

(a) The Recipient hereby agrees that it will incorporate or cause to be incorporated into any contract for construction work, or modification thereof, as defined in the regulations of the Secretary of Labor at 41 C.F.R. chapter 60, which is paid for in whole or in part with funds obtained from EDA, the following equal opportunity clause:

During the performance of this contract, the Contractor agrees as follows:

(1) The Contractor will not discriminate against any employee or applicant for employment because of race, color, religion, sex, or national origin. The Contractor will take affirmative action to ensure that applicants are employed, and that employees are treated during employment without regard to their race, color, religion, sex or national origin. Such action shall include, but not be limited to the following: Employment, upgrading, demotion, or transfer; recruitment or recruitment advertising; layoff or termination; rates of pay or other forms of compensation; and selection for training including apprenticeship. The Contractor agrees to post in conspicuous places available to employees and applicants for employment notices to be provided setting forth the provisions of this nondiscrimination clause.

(2) The Contractor will, in all solicitations or advertisements for employees placed by or on behalf of the Contractor state that all qualified applicants will receive consideration for employment without regard to race, color, religion, sex, or national origin.

(3) The Contractor will send to each labor union or representative of workers with which it has a collective bargaining agreement or other contract or understanding a notice to be provided advising the said labor union or workers representatives of the Contractor's

commitments hereunder, and shall post copies of the notice in conspicuous places available to employees and applicants for employment.

(4) The Contractor will comply with all provisions of Executive Order 11246 of September 24, 1965 and of the rules, regulations, and relevant orders of the Secretary of Labor.

(5) The Contractor will furnish all information and reports required by Executive Order 11246 of September 24, 1965, and pursuant to rules, regulations, and orders of the Secretary of Labor and will permit access to its books, records, and accounts by the Secretary of Labor for purposes of investigation to ascertain compliance with such rules, regulations, and orders.

(6) In the event of the Contractor's noncompliance with the nondiscrimination clauses of this Contract or with any of the said rules, regulations, or orders, this Contract may be canceled, terminated, or suspended in whole or in part and the Contractor may be declared ineligible for further Government contracts or federally-assisted construction contracts in accordance with procedures authorized in Executive Order 11246 of September 24, 1965, and such other sanctions may be imposed and remedies invoked as provided in Executive Order 11246 of September 24, 1965, or by rule, regulations or order of the Secretary of Labor, or as otherwise provided by law.

(7) The Contractor will include the portion of the sentence immediately preceding paragraph 17(a) (1) and the provisions of paragraphs 17(a)(1) through (6) in every subcontract or purchase order unless exempted by rules, regulations, or orders of the Secretary of Labor issued pursuant to section 204 of Executive Order 11246 of September 24, 1965, so that such provisions will be binding upon each subcontractor or vendor. The Contractor will take such action with respect to any subcontract or purchase order as EDA or the Secretary of Labor may direct as a means of enforcing such provisions, including sanctions for noncompliance. Provided, however, that in the event the Contractor becomes involved in or is threatened with litigation with or by a subcontractor or vendor as a result of such direction by EDA or the Secretary of Labor, the Contractor may request the United States to enter into such litigation to protect the interests of the United States.

(8) The Recipient further agrees that it will be bound by the above equal opportunity clause with respect to its own employment practices when it participates in federally-assisted construction work. Provided, however, that if the Recipient so participating is a State or local government, the above equal opportunity clause is not applicable to any agency, instrumentality, or subdivision of such government that does not participate in work on or under the Contract.

(9) The Recipient agrees that it will assist and cooperate actively with EDA and the Secretary of Labor in obtaining the compliance of contractors and subcontractors with the equal opportunity clause and the rules, regulations, and relevant orders of the Secretary of Labor, that it will furnish EDA and the Secretary of Labor such information as they may

require for the supervision of such compliance, and that it will otherwise assist EDA in the discharge of the EDA's primary responsibility for securing compliance.

(10) The Recipient further agrees that it will refrain from entering into any contract or contract modification subject to Executive Order 11246 of September 24, 1965, with a Contractor debarred from, or who has not demonstrated eligibility for, Government contracts and federally assisted construction contracts pursuant to the Executive order and will carry out such sanctions and penalties for violation of the equal opportunity clause as may be imposed upon contractors and subcontractors by EDA or the Secretary of Labor pursuant to Part II, Subpart D of the Executive order. In addition, the Recipient agrees that if it fails or refuses to comply with these undertakings, EDA may take any or all of the following actions: Cancel, terminate, or suspend in whole or in part this EDA financial assistance; refrain from extending any further assistance to the applicant under the program with respect to which the failure or refund occurred until satisfactory assurance of future compliance has been received from such applicant; and refer the case to the Department of Justice for appropriate legal proceedings.

(b) Exemptions to Above Equal Opportunity Clause (41 C.F.R. chapter 60):

(1) Contracts and subcontracts not exceeding \$10,000 (other than Government bills of lading) are exempt. The amount of the Contract, rather than the amount of the federal financial assistance, shall govern in determining the applicability of this exemption.

(2) Except in the case of subcontractors for the performance of construction work at the site of construction, the clause shall not be required to be inserted in subcontracts below the second tier.

(3) Contracts and subcontracts not exceeding \$10,000 for standard commercial supplies or raw materials are exempt.

18. CONTRACTING WITH SMALL, MINORITY AND WOMEN'S BUSINESSES

(a) If the Contractor intends to let any subcontracts for a portion of the work, the Contractor shall take affirmative steps to assure that small, minority and women's businesses are used when possible as sources of supplies, equipment, construction, and services.

(b) Affirmative steps shall consist of:

(1) Placing qualified small and minority businesses and women's business enterprises on solicitation lists;

(2) Ensuring that small and minority businesses and women's business enterprises are solicited whenever they are potential sources;

- (3) Dividing total requirements, when economically feasible, into smaller tasks or quantities to permit maximum participation by small and minority businesses and women's business enterprises;
- (4) Establishing delivery schedules, where the requirements of the contract permit, which encourage participation by small and minority businesses and women's business enterprises;
- (5) Using the services and assistance of the U.S. Small Business Administration, the Minority Business Development Agency of the U.S. Department of Commerce, and State and local governmental small business agencies;
- (6) Requiring each party to a subcontract to take the affirmative steps of this section; and
- (7) The Contractor is encouraged to procure goods and services from labor surplus area firms.

19. **HEALTH, SAFETY, AND ACCIDENT PREVENTION**

(a) In performing this contract, the Contractor shall:

- (1) Ensure that no laborer or mechanic shall be required to work in surroundings or under working conditions which are unsanitary, hazardous, or dangerous to their health and/or safety as determined under construction safety and health standards promulgated by the Secretary of Labor by regulation;
- (2) Protect the lives, health, and safety of other persons;
- (3) Prevent damage to property, materials, supplies, and equipment; and,
- (4) Avoid work interruptions.

(b) For these purposes, the Contractor shall:

- (1) Comply with regulations and standards issued by the Secretary of Labor at 29 C.F.R. part 1926. Failure to comply may result in imposition of sanctions pursuant to the Contract Work Hours and Safety Standards Act (40 U.S.C. § 3701 – 3708); and
- (2) Include the terms of this clause in every subcontract so that such terms will be binding on each subcontractor.

(c) The Contractor shall maintain an accurate record of exposure data on all accidents incident to work performed under this Contract resulting in death, traumatic injury, occupational disease, or damage to property, materials, supplies, or equipment, and shall report this data in the manner prescribed by 29 C.F.R. part 1904.

(d) The Owner shall notify the Contractor of any noncompliance with these requirements and of the corrective action required. This notice, when delivered to the Contractor or the Contractor's representative at the site of the Work, shall be deemed sufficient notice of the noncompliance and corrective action required. After receiving the notice, the Contractor shall immediately take corrective action. If the Contractor fails or refuses to take corrective action promptly, the Owner may issue an order stopping all or part of the Work until satisfactory corrective action has been taken. The Contractor shall not base any claim or request for equitable adjustment for additional time or money on any stop order issued under these circumstances.

(e) The Contractor shall be responsible for its subcontractors' compliance with the provisions of this clause. The Contractor shall take such action with respect to any subcontract as EDA, or the Secretary of Labor shall direct as a means of enforcing such provisions.

20. **CONFLICT OF INTEREST AND OTHER PROHIBITED INTERESTS**

(a) No official of the Owner who is authorized in such capacity and on behalf of the Owner to negotiate, make, accept, or approve, or to take part in negotiating, making, accepting, or approving any architectural, engineering, inspection, construction or material supply contract or any subcontract in connection with the construction of the Project, shall become directly or indirectly interested personally in this Contract or in any part hereof.

(b) No officer, employee, architect, attorney, engineer, or inspector of or for the Owner who is authorized in such capacity and on behalf of the Owner to exercise any legislative, executive, supervisory or other similar functions in connection with the construction of the Project, shall become directly or indirectly interested personally in this Contract or in any part thereof, any material supply contract, subcontract, insurance contract, or any other contract pertaining to the Project.

(c) The Contractor may not knowingly contract with a supplier or manufacturer if the individual or entity who prepared the Contract Documents has a corporate or financial affiliation with the supplier or manufacturer.

(d) The Owner's officers, employees, or agents shall not engage in the award or administration of this Contract if a conflict of interest, real or apparent, may be involved. Such a conflict may arise when: (i) the employee, officer or agent; (ii) any member of their immediate family; (iii) their partner or (iv) an organization that employs, or is about to employ, any of the above, has a financial interest in the Contractor. The Owner's officers, employees, or agents shall neither solicit nor accept gratuities, favors, or anything of monetary value from the Contractor or subcontractors.

(e) If the Owner finds after a notice and hearing that the Contractor, or any of the Contractor's agents or representatives, offered or gave gratuities (in the form of entertainment, gifts, or otherwise) to any official, employee, or agent of the Owner or EDA in an attempt to secure this Contract or favorable treatment in awarding, amending, or making any determinations related to the performance of this Contract, the Owner may, by written notice to the Contractor, terminate this Contract. The Owner may also pursue other rights and remedies that the law or this Contract

provides. However, the existence of the facts on which the Owner bases such findings shall be an issue and may be reviewed in proceedings under the dispute resolution provisions of this Contract.

(f) In the event this Contract is terminated as provided in paragraph (e) of this section, the Owner may pursue the same remedies against the Contractor as it could pursue in the event of a breach of this Contract by the Contractor. As a penalty, in addition to any other damages to which it may be entitled by law, the Owner may pursue exemplary damages in an amount (as determined by the Owner) which shall not be less than three nor more than ten times the costs the Contractor incurs in providing any such gratuities to any such officer or employee.

21. RESTRICTIONS ON LOBBYING

(a) This Contract, or subcontract is subject to section 319 of Public Law 101-121, which added section 1352, regarding lobbying restrictions, to chapter 13 of title 31 of the United States Code. The new section is explained in the common rule, 15 C.F.R. part 28 (55 FR 6736-6748, February 26, 1990). Each bidder under this Contract or subcontract is generally prohibited from using federal funds for lobbying the Executive or Legislative Branches of the Federal Government in connection with this EDA Award.

(b) **Contract Clause Threshold:** This Contract Clause regarding lobbying must be included in each bid for a contract or subcontract exceeding \$100,000 of federal funds at any tier under the EDA Award.

(c) **Certification and Disclosure:** Each bidder of a contract or subcontract exceeding \$100,000 of federal funds at any tier under the federal Award must file Form CD-512, *Certification Regarding Lobbying*, and, if applicable, Standard Form-LLL, *Disclosure of Lobbying Activities*, regarding the use of any nonfederal funds for lobbying. Certifications shall be retained by the Contractor or subcontractor at the next higher tier. All disclosure forms, however, shall be forwarded from tier to tier until received by the Recipient of the EDA Award, who shall forward all disclosure forms to EDA.

(d) **Continuing Disclosure Requirement:** Each Contractor or subcontractor that is subject to the Certification and Disclosure provision of this Contract Clause is required to file a disclosure form at the end of each calendar quarter in which there occurs any event that requires disclosure or that materially affects the accuracy of the information contained in any disclosure form previously filed by such person. Disclosure forms shall be forwarded from tier to tier until received by the Recipient of the EDA Award, who shall forward all disclosure forms to EDA.

(e) **Indian Tribes, Tribal Organizations, or Other Indian Organizations:** Indian tribes, tribal organizations, or any other Indian organizations, including Alaskan Native organizations, are excluded from the above lobbying restrictions and reporting requirements, but only with respect to expenditures that are by such tribes or organizations for lobbying activities permitted by other federal law. An Indian tribe or organization that is seeking an exclusion from Certification and Disclosure requirements must provide EDA with the citation of the provision or provisions of federal law upon which it relies to conduct lobbying activities that would otherwise

be subject to the prohibitions in and to the Certification and Disclosure requirements of section 319 of Public Law No. 101-121, preferably through an attorney's opinion. Note, also, that a non-Indian subrecipient, contractor, or subcontractor under an award to an Indian tribe, for example, is subject to the restrictions and reporting requirements.

22. HISTORICAL AND ARCHAEOLOGICAL DATA PRESERVATION

The Contractor agrees to facilitate the preservation and enhancement of structures and objects of historical, architectural or archaeological significance and when such items are found and/or unearthed during the course of project construction. Any excavation by the Contractor that uncovers an historical or archaeological artifact shall be immediately reported to the Owner and a representative of EDA. Construction shall be temporarily halted pending the notification process and further directions issued by EDA after consultation with the State Historic Preservation Officer (SHPO) for recovery of the items. *See* the National Historic Preservation Act of 1966 (80 Stat 915, 16 U.S.C. § 470) and Executive Order No. 11593 of May 31, 1971.

23. CLEAN AIR AND WATER

Applicable to Contracts in Excess of \$100,000

(a) **Definition.** "Facility" means any building, plant, installation, structure, mine, vessel, or other floating craft, location, or site of operations, owned, leased, or supervised by the Contractor or any subcontractor, used in the performance of the Contract or any subcontract. When a location or site of operations includes more than one building, plant, installation, or structure, the entire location or site shall be deemed a facility except when the Administrator, or a designee, of the United States Environmental Protection Agency (EPA) determines that independent facilities are collocated in one geographical area.

(b) In compliance with regulations issued by the EPA, 2 C.F.R. part 1532, pursuant to the Clean Air Act, as amended (42 U.S.C. § 7401 *et seq.*); the Federal Water Pollution Control Act, as amended (33 U.S.C. § 1251 *et seq.*); and Executive Order 11738, the Contractor agrees to:

- (1) Not utilize any facility in the performance of this contract or any subcontract which is listed on the EPA List of Violating Facilities pursuant to 2 C.F.R. part 1532 for the duration of time that the facility remains on the list;
- (2) Promptly notify the Owner if a facility the Contractor intends to use in the performance of this contract is on the EPA List of Violating Facilities or the Contractor knows that it has been recommended to be placed on the List;
- (3) Comply with all requirements of the Clean Air Act and the Federal Water Pollution Control Act, including the requirements of section 114 of the Clean Air Act and section 308 of the Federal Water Pollution Control Act, and all applicable clean air and clean water standards; and

(4) Include or cause to be included the provisions of this clause in every subcontract and take such action as EDA may direct as a means of enforcing such provisions.

24. **USE OF LEAD-BASED PAINTS ON RESIDENTIAL STRUCTURES**

(a) If the work under this Contract involves construction or rehabilitation of residential structures, the Contractor shall comply with the Lead-based Paint Poisoning Prevention Act (42 U.S.C. § 4831). The Contractor shall assure that paint used on the Project on applicable surfaces does not contain lead in excess of the percentages set forth in Paragraphs (a) and (b) of this section. In determining compliance with these standards, the lead content of the paint shall be measured on the basis of the total nonvolatile content of the paint or on the basis of an equivalent measure of lead in the dried film of paint already applied.

(1) For paint manufactured after June 22, 1977, paint may not contain lead in excess of 6 one-hundredths of 1 percent (.0006) lead by weight.

(2) For paint manufactured on or before June 22, 1977, paint may not contain lead in excess of five-tenths of 1 percent lead by weight.

(b) As a condition to receiving assistance under PWEDA, recipients shall assure that the restriction against the use of lead-based paint is included in all contracts and subcontracts involving the use of federal funds.

(c) **Definitions**

(1) "Applicable surfaces" are those exterior surfaces which are readily accessible to children under seven years of age.

(2) "Residential structures" means houses, apartments, or other structures intended for human habitation, including institutional structures where persons reside, which are accessible to children under seven years of age, such as day care centers, intermediate and extended care facilities, and certain community facilities.

25. **ENERGY EFFICIENCY**

The Contractor shall comply with all standards and policies relating to energy efficiency which are contained in the energy conservation plan issued in compliance with the Energy Policy and Conservation Act (Public L. No. 94-163) for the State in which the Work under the Contract is performed.

26. **ENVIRONMENTAL REQUIREMENTS**

When constructing a Project involving trenching and/or other related earth excavations, the Contractor shall comply with the following environmental constraints:

(1) **Wetlands.** When disposing of excess, spoil, or other construction materials on public or private property, the Contractor shall not fill in or otherwise convert wetlands.

(2) **Floodplains.** When disposing of excess, spoil, or other construction materials on public or private property, the Contractor shall not fill in or otherwise convert 100 year floodplain areas delineated on the latest Federal Emergency Management Agency (FEMA) Floodplain Maps, or other appropriate maps, i.e., alluvial soils on Natural Resource Conservation Service (NRCS) Soil Survey Maps.

(4) **Endangered Species.** The Contractor shall comply with the Endangered Species Act, which provides for the protection of endangered and/or threatened species and critical habitat. Should any evidence of the presence of endangered and/or threatened species or their critical habitat be brought to the attention of the Contractor, the Contractor will immediately report this evidence to the Owner and a representative of EDA. Construction shall be temporarily halted pending the notification process and further directions issued by EDA after consultation with the U.S. Fish and Wildlife Service.

27. **DEBARMENT, SUSPENSION, INELIGIBILITY, AND VOLUNTARY EXCLUSIONS**

As required by Executive Order 12549, *Debarment and Suspension*, and implemented at 2 C.F.R. part 1326, for prospective participants in lower tier covered transactions (except subcontracts for goods or services under the \$25,000 small purchase threshold unless the subrecipient will have a critical influence on or substantive control over the award), as defined at 2 C.F.R. part 1326.

(1) By entering into this Contract, and by further executing Form CD-512, the Contractor and subcontractors certify, that neither it nor its principals is presently debarred, suspended, proposed for debarment, declared ineligible, or voluntarily excluded from participation in this Contract by any federal department or agency.

(2) Where the Contractor or subcontractors are unable to certify to any of the statements in this certification, the Contractor or subcontractors shall attach an explanation to this bid.

See also 15 C.F.R. §§ 14.13 or 24.35, as applicable.

28. **EDA PROJECT SIGN**

The Contractor shall supply, erect, and maintain in good condition a Project sign according to the specifications provided by EDA. To the extent practical, the sign should be a free standing sign. Project signs shall not be located on public highway rights-of-way. Location and height of signs will be coordinated with the local agency responsible for highway or street safety in the Project area, if any possibility exists for obstructing vehicular traffic line of sight. Whenever the EDA site sign specifications conflict with State law or local ordinances, the EDA Regional Director will permit such conflicting specifications to be modified so as to comply with State law or local ordinance.

EDA PROJECT SIGN

The Contractor shall supply, erect, and maintain in good condition a project sign according to the specifications set forth below:

EDA SITE SIGN SPECIFICATIONS

Size: 4' x 8' x ¾"

Materials: Exterior grade/MDO plywood (APA rating A-B)

Supports: 4" x 4" x 12' posts with 2" x 4" cross branching

Erection: Posts shall be set a minimum of three feet deep in concrete footings that are at least 12" in diameter.

Paint: Outdoor enamel

Colors: Jet Black, Blue (PMS300), and Gold (PMS7406). Specifically, on white background the following will be placed:

The U. S. Department of Commerce seal in blue, black, and gold;

“EDA” in blue;

“U. S. DEPARTMENT OF COMMERCE ECONOMIC DEVELOPMENT
ADMINISTRATION” in black;

“In partnership with” in blue;

(Actual name of the) “Investment Recipient” in black;

“PUTTING AMERICA TO WORK” in blue;

“Barack Obama, President of the United States” in black.

Lettering: Specific fonts are named below; positioning will be as shown on the attached illustration.

“U. S. DEPARTMENT OF COMMERCE ECONOMIC DEVELOPMENT
ADMINISTRATION” use Bank Gothic Medium - **BANK GOTHIC MED**

“In partnership with” use Univers™ 55 Oblique - *Univers 55*

(Name of) “Investment Recipient” use Univers™ Extra Black 85 - **Univers 85**

“PUTTING AMERICA TO WORK” use Walkway Black - **Walkway**

“Barack Obama, President of the United States” use Univers™ 55 Oblique - *Univers 55*

Project signs will not be erected on public highway rights-of-way. If any possibility exists for obstruction to traffic line of sight, the location and height of the sign will be coordinated with the agency responsible for highway or street safety in the area.

The EDA Regional Director may permit modifications to these specifications if they conflict with state law or local ordinances.

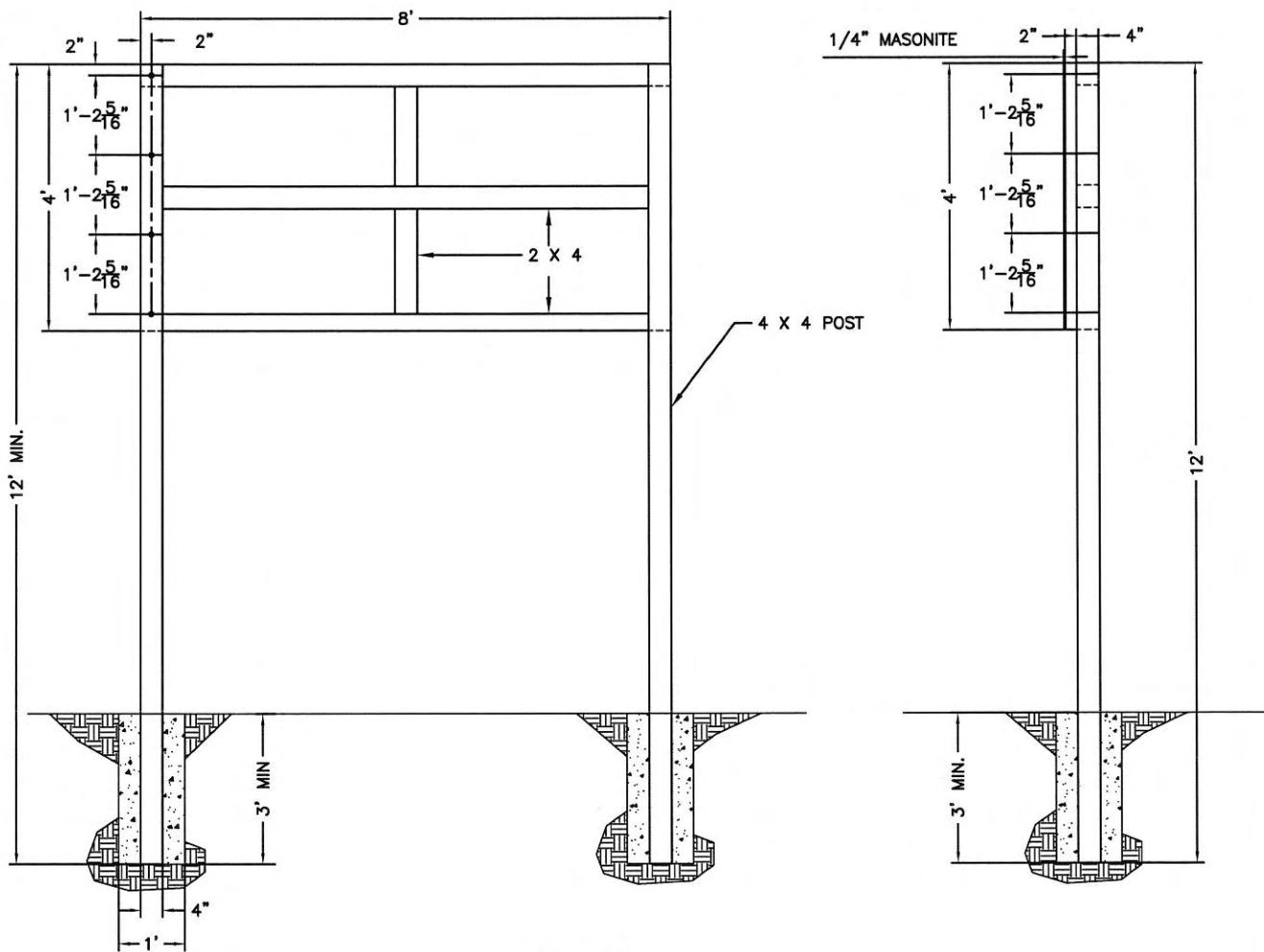

SIGN A
 MASONITE SIGN
 SCALE: 3/8" = 1'

PROJECT - SIGN A
ECONOMIC DEVELOPMENT ADMINISTRATION



EEDA

U.S. DEPARTMENT OF COMMERCE ECONOMIC DEVELOPMENT ADMINISTRATION

In partnership with

Recipient Name

PUTTING AMERICA TO WORK

Barack Obama, President of the United States

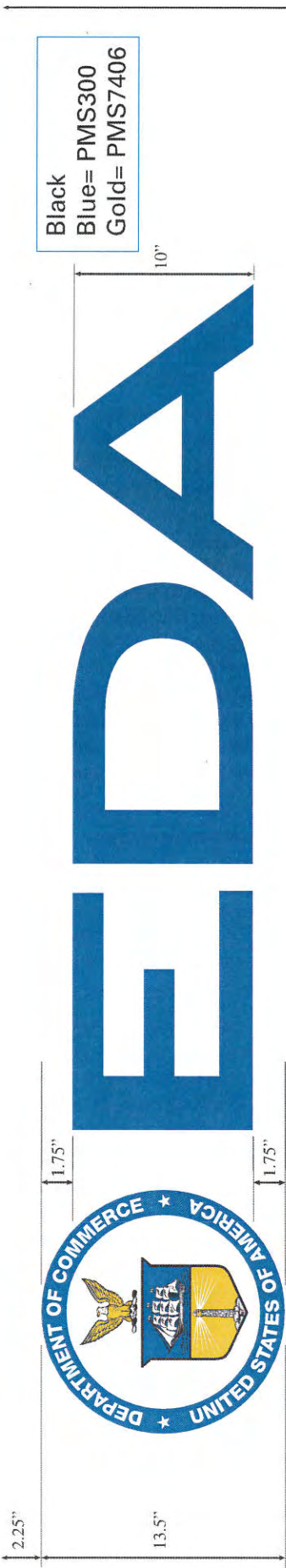

U.S. DEPARTMENT OF COMMERCE ECONOMIC DEVELOPMENT ADMINISTRATION

In partnership with

Recipient Name

PUTTING AMERICA TO WORK

Barack Obama, President of the United States



INSTALLATION OF SEWER MAIN

1. City Water & Light (CWL) will serve as Owner's Designated Representative for this work.
2. Contractor shall be responsible for requesting locates of all utilities in the designated work area. Contractor shall mark the work area where work is to be performed. Contractor shall notify Arkansas One Call @ 1-800-482-8998. 48-hour notice is required by Arkansas One Call.
3. Contractor shall be responsible for damages to utilities if proper locates were furnished. If damages occur due to improper locates, the contractor shall work with the utility owner involved to settle any disputes or claims for damages.
4. Contractor shall be responsible for maintaining a good working relationship with any and all property owners where work may affect their property. Contractor shall work to resolve any conflicts. Any conflicts between the Contractor and the property owner that cannot be resolved will be referred to the Owner's Designated Representative.
5. Contractor shall perform all work in a safe manner in accordance with all Arkansas Department of Labor Safety Codes and all Occupational Safety & Health Administration (OSHA) Regulations. Contractor shall be responsible for the safety of the contractor's employees while on the job. Contractor shall be responsible for the safety of the general public as it relates to the work site of the work being performed. This includes safety of the work site.
6. Contractor shall abide by the U.S. Department of Transportations Manual on Uniform Traffic Control Devices (MUTCD) Millennium Edition 2000 (or the most current issue) Part 6 Temporary Traffic Control – Work Zones.
7. Any work affecting city streets, county roads, state highways, private drives, driveways, mailboxes, paper boxes (any structures removed for purposes of work) shall be the contractors responsibility for re-storing, repairing, or replacing to their original state, unless specifications for such are presented to contractor by owner which meets a Federal, State, or City requirement.
8. Contractor shall not assign or sublet any portion of this contract without prior approval from the Owner and Owner's Designated Representative. **If approved, Contractor must provide lien releases from sub-contractors before final billing.**
9. Owner's Designated Representative assigned Inspector shall make inspections of work being performed.
10. Contractor shall use a pipeline laser.

11. Pipe shall be installed in accordance with ASTM Manual for installation of PVC sewer pipe.
12. Pipe shall be bedded and backfilled in compliance with Class B bedding Specification.
13. Contractor shall secure all utility lines to avoid damages due to excavation, and is responsible for repairs if they are damaged.
14. Contractor, when working around power lines, will be responsible for making arrangements with utility company for "tying off" poles, and the safety of contractors employees working in the vicinity of power lines (overhead or underground).
15. Contractor shall be responsible for leaks related to the installation of lines and shall be required to air test as per ASTM C828-80.
16. Air test must be satisfactorily completed before acceptance of pipeline.
17. Manholes shall be vacuum tested as per ASTM C1244.
18. Contractor shall be responsible to backfill by pushing dirt back over pipe for natural settlement to occur after haunching and initial backfill, unless otherwise specified.
19. Excess soil shall be left on site for the Owner's use.
20. Owner's Designated Representative shall furnish manhole stations and grade information at the request of the contractor.
21. Contractor shall record and furnish accurate measurements of distances between fittings on mains, such as wyes and manholes.
22. When trench/excavation equals or exceeds five (5) feet in depth, the contractor shall meet all provisions of the current Occupational Safety and Health Administration (OSHA) Standard for Excavation & Trenches Safety Systems 29 CFR 1926 Subpart P.

SPECIFICATIONS
WATER AND SEWER CONSTRUCTION

CITY WATER AND LIGHT

JONESBORO, ARKANSAS

Date of Last Revision: October 12, 2007

CWL Specifications

SECTION 1 – PLANS, CONTRACTS, & GENERAL INFORMATION

1-01. Refunding:

When extending a water or sewer main across other property owners, a refunding contract can be requested. The developer's engineer should make available for review a refunding drawing showing the appropriate footage. CWL's Engineering Department will publish the per foot cost each calendar year.

1-02. Profiles:

All profiles must be drawn from an actual ground survey, not from a topographic map. The survey notes should accompany the submittal.

1-03. **Plans must have MAPC approval before final acceptance of system.**

SECTION 2 – OVERALL SITE WORK

2-01. **Description:**

- (a) Final clean-up of the site shall include the removal and disposal off-site of all construction debris, temporary plant, and surplus materials.
- (b) This section covers the items that follow:
 - (1) Intermittent clean-up
 - (2) Clearing right-of-way
 - (3) Existing storm drainage pipes
 - (4) Private driveways and gravel roads outside city limits
 - (5) Roadways inside city limits
 - (6) Roadways inside new subdivisions
 - (7) Location of new water and sewer mains

2-02. **Intermittent Clean-up:**

From time to time, all litter and debris shall be removed from the site and disposed of off-site, such that the site presents a neat appearance and the progress of work is not impeded.

2-03. **Clearing Right-of-Way:**

All natural or man-made obstructions shall be removed, including the cutting of existing surfacing, as necessary to permit the new construction. As soon as possible, each manmade obstruction shall be restored to the original condition within reasonable economic limits.

2-04. **Existing Storm Drainage Pipe:**

- (a) Obstructing drainage pipes, shall be removed. If in sound, undamaged condition, they may be cleaned and re-laid. If unsound or damaged, they shall be replaced with pipes in kind.
- (b) When the angle between center lines of a drainage pipe and water main will permit, the water main may be installed by tunneling, provided the drainage pipe is not damaged and the water main is laid properly. As an alternative in the case of corrugated metal pipe, a section may be cut from the drainage pipe, and restoration accomplished with new pipe and coupling bands.

2-05. **Private Driveways and Gravel Roads Outside City Limits:**

Existing gravel roads outside city limits shall be filled with ¾” minus crushed stone and tamped, with all debris removed to be disposed of off site. **This includes all existing private drives.**

Percent By Weight Passing

<u>Size Sleeve</u>	<u>Gravel</u>	<u>Crushed Stone</u>
1-1/2”	100	-----
1”	85-100	100
¾”	60-90	50 – 90
3/8”	40-80	-----
No. 4	30-60	25 – 50
No. 10	20-45	-----
No. 40	10-35	10 – 30
No. 100	3-12	3 – 10

CWL Specifications

2-06. Roadways Inside City Limits:

(a) Excavations to be Restored with Flowable Fill:

All material excavated for the street cut shall be removed and disposed of by the person, firm, or corporation performing said excavation. All excavations shall be restored with flowable fill to within 2" of the surrounding bituminous riding surface.* The mix design for the flowable fill will be prepared by the Applicant. The mixture will be proportioned to produce a flowable mixture without segregation, material for one cubic yard, absolute volume, and shall be as follows:

Cement	80-100 lbs.
Fly Ash	220-300 lbs.
Sand	Variable to equal 1 cubic yard
Water	Approximately 65 gallons

The minimum flow shall be 8". The unit weight shall be a minimum of 110 lbs/ft³.

* If the surrounding riding surface is concrete, flowable fill shall be placed to within 6" of the riding surface.

The flow test shall consist of filling a 3" diameter x 6" high open-ended cylinder to the top with the flowable material mixture. If necessary, the top of the mixture will be struck off level. The cylinder will then be pulled straight up and the flow will be measured by the approximate diameter of the mixture.

Placing of either bituminous hot mix for asphalt surfaces or concrete for concrete surfaces over the flowable fill may begin after the flowable material has taken its initial set, is stable, and does not displace under equipment. A tack coat of liquid asphalt shall be applied to the cut face of the surrounding asphalt pavement before final hot mix surface is placed. Steel plates shall be used to maintain traffic over cuts before flowable fill is placed if necessary and also during the curing time of the flowable fill. These steel plates shall be provided by the City of Jonesboro Street Department. All pavement restoration shall be made by the City of Jonesboro Street Department.

In the event a cut is to be restored during a time when hot asphalt plant mix is not available, cold plant mix may be used as a temporary surface until a time hot plant mix is available. It shall be the applicants responsibility to maintain the cold mix patch until replaced with hot plant mix. The initial deposit will not be released until hot plant mix is in place and a final inspection has been made.

(b) Limits of Excavations:

The limits of cuts to be restored shall be as follows:

- (1) All longitudinal cuts within 5' of the edge of the paved surface.
- (2) All transverse cuts to a distance of 3' beyond the edge of a paved surface.
- (3) When the excavation is not within a gravel surface or concrete or bituminous surface the flowable fill shall be placed to within 6" of the surrounding ground. The remaining 6" shall be filled with topsoil and seeded. No cuts shall be made within 200' of a signalized intersection until the City of Jonesboro Engineering Department has been notified to locate traffic detection loops
- (4) All asphalt and concrete surfaces must be cut with a saw or air chisel.

2-07. Roadways Inside New Subdivision:

In a proposed area, (new subdivisions) all street cuts shall be back-filled with fill sand and tamped.

CWL Specifications

2-08. Location of New Water or Sewer Mains:

- (a) Water and sewer lines should be placed on City, County, or State Right of Way or on an easement parallel and adjacent to the Right of Way.
- (b) Water and sewer lines should be placed on opposite sides of the Right of Way. If an exception is required, Water and Sewer lines must have a minimum of 10 feet horizontal separation and a minimum of 18 inches vertical separation.
- (c) Easements should be 20 feet in width. Where other utilities are present, additional width may be required.
- (d) Water and sewer lines shall be a minimum of 10 feet from permanent structures.
- (e) Wyes or manhole stubouts shall be installed at the low elevation of each lot.
- (f) CWL Engineering Dept. must approve any water or sewer lines that will be installed closer than 5' parallel with edge of paved street surface.

SECTION 3 – EXCAVATION, BACKFILL, AND FILLS

3-01. Description:

This section covers excavation and backfill in construction installations and operations as follows:

- (a) The trench excavation for the water and sewer pipe.
- (b) Bedding
- (c) The back-filling of pipe lines and all other installations for which excavations are made.

3-02. Proximity To Existing Utilities:

- (a) At many locations, the new lines are very close to existing utilities, and in many instances, pass beneath the existing utility. In all such cases the existing utilities shall be protected from damage.
- (b) Before doing any excavating it shall be requested that the utility companies locate their underground utilities.
- (c) In the event of a damaged utility line during excavation, the particular utility will be contacted immediately so as to expedite the line's repair.

3-03. Trench Excavation For Water and Sewer Force Main:

The width of the trench shall be ample to permit the pipe to be laid and jointed properly, and the backfill to be properly replaced. Trenches shall be of such extra width, when required, as will permit the convenient placing of trench boxes for the protection of laborers, the work, and adjoining property. Trench depth will be such as to allow a minimum cover of 42" over water main. The width of the trench shall be a minimum of 24" when installing electric conduit and water mains in the same trench with conduit always on curb side, and minimum separation of 6 inches between conduit and water main.

3-04. Bedding Materials:

- (a) All backfill material shall be free from cinder, ashes, refuse, vegetable or organic material, boulders, rock or stones, or other material which is unsuitable.
- (b) When the type of backfill material is not indicated, excavated material may be used, provided that such material consists of loam, clay, sand, gravel, or other materials which are suitable for back-filling.
- (c) All trenches shall be back-filled by hand, from the bottom of the trench to the centerline of the pipe with approved material placed in layers of three (3) inches and compacted by tamping. Back-filling material shall be deposited in the trench for its full width on each side of the pipe, fittings, and appurtenances simultaneously.
- (d) Should rock be encountered, trench will be back-filled with suitable bedding material a minimum of 6" over said rock.
- (e) Bedding material for PVC water mains shall have no angular particles larger than 1" and no rounded particles larger than 1½".

3-05. Disposition of Excavated Materials:

To the extent suitable and needed, excavated materials shall be used in the formation of backfill. Materials not used for the formation of backfill shall be disposed of off-site.

SECTION 4 – WATER PIPE AND FITTINGS

4-01. **Description:**

This section covers the installation of all water pipe and fittings. Water lines will be constructed of Class 350 ductile iron pipe or PVC pipe with ductile iron or cast iron fittings.

4-02. **Materials:**

- (a) Ductile iron pipe shall be thickness Class 350 and shall be lined with cement mortar.
- (b) PVC pipe shall have a Pressure Rating (PR) of 200 (SDR 21) conforming to ASTM D2241 and ASTM D3139 or better for pipe sizes up to 3 inches.
- (c) For 4” through 12” pipe, PVC pipe shall be AWWA C-900 Pressure Pipe DR18 (Pressure Class 150) meeting ANSI/AWWA C-900 standard for pressure pipe or better.
- (d) Fittings shall conform to the specifications of 4-01 above.
- (e) Joints shall be compression-type resilient joints, or flanged. Lubricant for push-on type joints shall be that recommended by the manufacturer of the pipe.

4-03. **Trench Excavation and Backfill:**

Trench excavation and backfill shall be in accordance with the requirements of SECTION 3 – EXCAVATION, BACKFILL, AND FILLS.

4-04. **Equipment:**

All equipment necessary and required for the proper construction of the line shall be in first class working condition.

4-05. **Laying Pipe:**

- (a) All soil and other foreign matter shall be removed from the inside of the pipe and fittings before they are lowered into the trench. They shall be kept clean during and after laying; care shall be taken to keep soil out of the jointing space. At the end of each day’s work, pipe shall be closed with a water tight plug.
- (b) All pipe and fittings shall be lowered carefully into the trench in such manner as to prevent damage to pipe, fittings, or linings. Neither pipe nor fittings shall be dropped or dumped into the trench.
- (c) Cutting of pipe, where needed, shall be done in a neat and workmanlike manner without damage to pipe or pipe lining.
- (d) Unless otherwise directed, pipe shall be laid with bell ends facing in the direction of laying. For lines on an appreciable slope, bells shall, at the engineer’s direction, face upgrade. Wherever necessary to avoid obstruction, or for other allowable reasons, the degree of deflection at any joint shall not be greater than that which will provide adequate gasket space entirely around the spigot end of pipe. The joint opening shall be approximately 1/8 inch. Maximum allowable deflections shall be as limited by the pipe manufacturer’s recommendations.
- (e) Pipe shall not be laid in water, when the trench condition is unsuitable, or the weather is unsuitable for such work.
- (f) All pipe shall be laid at a sufficient depth to maintain 42” minimum cover, measured from the top of the pipe to the existing grade of the surrounding undisturbed soil. The only exception to this requirement will be for channel crossings greater than 5 feet which is detailed in 6-04 CHANNEL CROSSINGS.
- (g) Stranded 16 gauge locator wire shall be installed with markers every 750 feet, unless the water line is in a common trench with an electric line.

4-06. **Installation of Slip-Type Joints:**

- (a) Prior to jointing, the bell and spigot ends of the pipes, and bells of fittings shall be cleaned thoroughly with soapy water and cloth, or by whatever means are necessary to remove all foreign matter and attain the required cleanliness. A wire brush shall be used if necessary. Particular care shall be exercised to clean the gasket seat. The gland also shall be cleaned in like manner.

CWL Specifications

- (b) Joints shall be made in strict accord with the recommendations of the pipe manufacturer. The rubber gasket shall be cleaned with soapy water and/or cloth and inserted in the gasket seat within the bell. The spigot end of the pipe shall be inserted into the bell of the pipe to which connection is being made, and forced to a firm contact with the shoulder of the bell. When this initial insertion is made, the alignment of the added pipe shall deviate from true alignment not more than the amount recommended by the manufacturer.
- (c) Following the initial insertion, the bell end of the added pipe shall be moved sideways or up a distance of approximately 8 inches to move the spigot end slightly away from the shoulder of the connecting bell, thus providing for expansion and flexibility in the completed line. The added pipe shall be placed in true alignment at intended grade.
- (d) Radius of Curvature: bending of pipe around curves or in coves shall not exceed that of the recommendations of the pipe manufacturer or refer to the PVC pipe handbook.

4-07. **Installation of Mechanical Joints:**

- (a) The spigot end of pipe and the bell of fittings, and the rubber gasket, shall be cleaned thoroughly as specified for pipe joints in paragraph 4-06 (a) above. The gland also shall be cleaned in like manner.
- (b) After the gland and gasket are placed on the spigot end of the pipe a sufficient distance from the end to avoid fouling the bell, the spigot end shall be inserted in the bell to firm contact with the bell shoulder. The rubber gasket then shall be advanced into the bell and seated in the gasket seat. Care should be exercised to center the spigot end within the bell.
- (c) The gland shall be brought into contact with the gasket, all bolts entered, and all nuts hand tightened. Continued care shall be exercised to keep spigot centered in bell. The joint shall be made tight by turning the nuts with a wrench; first partially tightening a nut, then partially tightening the nut 180 degrees there from, and working thus around the pipe, with uniformly applied tension until the required torque is applied to all nuts. Required torque ranges and indicated wrench lengths for standard bolts are as follows:

<u>Diameter</u>	<u>Range of Torque</u>	<u>Length of Wrench</u>
(inches)	(foot – pounds)	(inches)
5/8"	40 – 60	8
3/4"	60 – 90	10
1"	70 – 100	12
1-1/4"	90 – 120	14

4-08. **Leakage Tests:**

- (a) Leakage tests shall be made on all contractor laid water lines.
- (b) Leakage tests shall be made prior to sterilization operations.
- (c) The test period shall be two (2) hours. Test pressure shall be 1.5 times the calculated working pressure of the main, but not less than 100 psi.
- (d) The line will not be accepted unless or until the total is less than that specified in AWWA C-600-93 for ductile iron and AWWA C-605-94 for PVC pipe.

Allowable leakage (L) shall be according to the following equation:

$$L = \{[ND(P)^{1/2}] \div 7400\}$$

- where
- N = number of joints
 - D = diameter of pipe in inches
 - P = test pressure in psi
 - L = allowable leakage in gallons per hour (gph)**

CWL Specifications

4-09. Sterilization:

- (a) All water lines shall be sterilized in accordance with AWWA C-651-94. Any new construction or repaired water main must be thoroughly cleaned (flushed), disinfected, and tested for bacteriological quality before it can be placed in service.
- (b) The manner in which the lines are sterilized shall be one that is approved for potable water systems by the Arkansas Department of Health.
- (c) Following a contact period of not less than 24 hours, the chlorinated water shall be flushed from the system, and the system filled with water of normal chlorine content. Samples of water then shall be taken on two consecutive days from the lines and delivered to the CWL – LABORATORY for bacterial analysis. This process shall be continued until the samples show the water is safe for domestic requirements. .
- (d) All valves in sections of lines being sterilized shall be opened and closed at least twice during the sterilization period.
- (e) Flushing devices should be sized to provide flows which will give a velocity of at least 2.5 feet per second in the water main being flushed. No flushing device shall be directly connected to any sewer.

Pipe Diameter	Flow Required to Produce
Inches	2.5 FPS Velocity (approx)
	GPM
4	100
6	200
8	400
10	600
12	900
16	1600

CWL Specifications

4-10 Flushing Guidelines

- a. The contractor will be responsible for flushing the new water mains they install. The contractor will flush the mains under the supervision of the CWL inspector. (Flushing on special jobs will require advanced planning and coordination with customers and may require work after normal working hours to meet the needs of the water demand.)
- b. A flushing plan should be in the bid package that is given to contractors invited to bid on CWL water jobs. If the water extension is designed by a consulting engineer, a flushing plan will be required prior to review.
- c. The CWL Inspector will witness the flushing and transport bacteriological samples to the CWL lab for analysis. There will be no cost to the contractor from the CWL lab. If the contractor chooses, he can split the samples and independently analyze the water quality at another lab. The CWL lab results will control acceptance.
- d. Once the CWL lab certifies the water as safe, all valves except for normally closed valves, will be placed in the open position. The CWL Inspector will verify that all valves are in the proper position. (Generally valves will be closed after flushing and open after bacteriological tests have passed.)
- e. The CWL Inspector will send a flushing ticket to the Water Department if the line has set for a one month or longer before final acceptance.
- f. The CWL Inspector will fill out a Valve Operation Record after final acceptance and route to General Operations Associate for official transfer from Engineering to the Water Department.
- g. Each Fire Hydrant shall be flushed.

4-11 Repairs

- a. Repairs shall be made in accordance with AWWA.
- b. If valve is closed by the contractor without CWL's knowledge, the new section must be tested for water quality and flushed.
- c. The CWL Inspector will witness all repairs.

SECTION 5 – VALVES

5-01. Description:

This section covers:

- (a) Gate valves
- (b) Check valves
- (c) Butterfly valves
- (d) Tapping connections
- (e) Extensions to existing mains

5-02. Gate Valves:

- (a) Gate valves shall be set properly and joined to the pipe as specified for the making of joints in SECTION 4 – WATER PIPE AND FITTINGS.
- (b) Gate valves shall conform to American Water Works Association Standard Specifications for iron body, bronze mounted, non-rising stem gate valves. Valves shall be open left, double-disc, parallel seat type, for working water pressure of 200 psi.

5-03. Check Valves:

Well discharge check valves shall be iron body, bronze mounted, horizontal swing check valves with outside weight and lever and designed for 175 psi working pressure. Check valves shall conform to AWWA C-508.

CWL Specifications

5-04. **Butterfly Valves:**

- (a) Butterfly valves shall be installed in accordance with the requirements of subparagraph 5-02 above.
- (b) Buried butterfly valves shall be equal to Pratt "Groundhog" valves as manufactured by Henry Pratt Company, 401 S. Highland, Aurora, IL 60507.
- (c) All butterfly valves shall be rubber-seated, tight-closing type with the seat bonded and mechanically secured to the body in such manner as to serve as a flange gasket. Body and disc shall be heavy duty cast iron or cast steel, with straight-through shaft of stainless steel.
- (d) Butterfly valves shall meet the requirements of AWWA Standard C-504 for Rubber-Slated Butterfly Valves, current issue.

5-05. **Tapping Connections:**

- (a) Extensions of existing mains is covered in the paragraph that follows. This paragraph covers connections where taps are made.
- (b) Tapping connections shall consist of tapping sleeves and companion tapping valves. They shall be designed for working water pressure of 200 psi.
 - (1) Sleeves shall have mechanical joint ends encircling the main and the outlet openings shall be flanged for attachment of the inlet sides of the tapping valves.
 - (2) Tapping sleeves that are used on transite water mains must be full circle and stainless steel.
 - (3) Valves shall conform to the applicable specifications for gate valves set out in paragraph 5-02 above. The inlet openings shall be flanged and the outlet openings shall have mechanical joint ends.
- (c) Installation of Tapping Connections:
 - (1) Sleeves shall be fastened securely to the pipe to be tapped. Cleaning of pipe and sleeves, and attachment of sleeves, shall be in accordance with applicable stipulations of SECTION 4 – WATER PIPE AND FITTINGS. The sleeve shall be so positioned that the valve stem of the tapping valve will be plumb.
 - (2) Tapping valves shall be bolted securely to the flanges of the sleeves, and the tapping machine connected to the mechanical joint end. Cleaning of flanges, mechanical joints, and gaskets, and the connecting of sleeves, valves, and machine, shall be in accordance with applicable stipulations of SECTION 4 – WATER PIPE AND FITTINGS.
 - (3) All taps will be performed by CWL – for CWL or for developers for a said fee. These tapping valves shall be operated under the direction of a CWL representative only.
- (d) Installation of Tees:
 - (1) Tees installed for branch lines shall have a valve installed for each line.
 - (2) All valves shall be secured to tee with an anchor coupling.

5-06. **Extensions of Existing Mains:**

- (a) Where the existing main ends in a plugged pipe or with a washout, the extension will begin with the installation of a mechanical joint valve. In some circumstances, the extension (at CWL's discretion) shall begin with a tapping valve so that the existing area is not valved off. Extensions shall be in accordance with applicable provisions of SECTION 4. Where new extensions end, and future extension is likely, it shall end with a wash-out or fire hydrant with proper size gate valve with concrete backing a minimum of 12' before end of new line.
- (b) Washouts – where an extension of a new main ends with a wash-out and main size is an 8" diameter pipe, the wash-out installed shall be that of a 3" diameter pipe. An in line valve shall be installed in accordance with SECTION 5-06-a.
- (c) An extension of a new main size that is a 10" diameter pipe of greater shall end with a fire hydrant.

SECTION 6 – HIGHWAY, RAILROAD, AND CHANNEL CROSSINGS

6-01. Crossing Requirements:

- (a) Water pipe passing beneath highways and railroads shall be threaded through steel encasement pipe after the appropriate permits have been obtained.
- (b) For highway crossings, solid encasement pipe shall be used within the limits set by the Arkansas State Highway Department. Such limits presently are to be from Right-of-Way to Right-of-Way.
- (c) For railroad crossings, the limits of solid pipe shall be determined by the involved railroad company. Such limits are presently from Right-of-Way to Right-of-Way.
- (d) Excavation for the steel encasement pipe shall be by the dry bore method.

6-02. Encasement Pipe:

- (a) Solid encasement pipe shall be fabricated from plate conforming to current ASTM Designation A 36. Dimensions shall conform to the following, except when the State Highway Department or Railroad companies require a thicker wall.

<u>Nominal Carrier Diameter</u>	<u>Outside Diameter Encasement</u>	<u>Wall Thickness Thickness</u>
24"	36"	¼"
20"	30"	¼"
16"	24"	¼"
12"	20"	¼"
8"	16"	¼"
6"	12"	¼"
4"	12"	¼"

6-03. Installing Pipe In Encasement:

Pipe for installation in encasement shall be ductile iron fastite or mechanical joint type. The pipe shall be threaded through the encasement in such manner that the joints will be in compression and none shall be under tension.

6-04. Channel Crossings:

- (a) Water pipe crossing ditches, streams, or canals will be installed as nearly perpendicular to the flowline of the channel as possible. Channels wider than 5 feet will be crossed by one of the following methods:
 - (1) Boring and installing a 12" steel casing under the channel;
 - (2) Dewatering the channel, excavating a trench, and installing 12" steel casing in the open trench;
 - (3) Dewatering and installing the water pipe directly in an open trench 3 pipe diameters wide and at least 36" below the flowline of the channel and encasing the pipe in concrete continuously across the channel to a distance of 5 feet outside the channel on each side.
- (b) In all 3 options in 6-04 (a), the carrier pipe will be ductile iron to a distance of 10 feet outside the ditch bank.
- (c) Options (1) and (2) in 6-04 (a) will require reinforced concrete collars to anchor both ends of the casing outside the ditch bank.
- (d) Ditches less than 5 feet wide will be dewatered and crossed as nearly perpendicular as possible by installing the water line below the flowline at least 42 inches.
- (e) Channels exceeding 40' in width shall have proper size gate valve installed on each side.

SECTION 7 – FIRE HYDRANTS

7-01. **Description: (revised 10-9-2006)**

Fire hydrants shall be Mueller Company type only – three spud hydrant #A-423, 5-1/4” main valve opening, 3 way, 2 – 2 1/2” hose nozzles, 1 – 4 1/2” pumper nozzle, 4’0” bury, 6” M.J. shoe, pentagon nut, open left, NST.

7-02. **Installation of Fire Hydrant:**

- (a) The hydrant shall be cleaned thoroughly before being set; all dirt and foreign matter shall be removed from barrel and bottom section, and the waste outlet freed of any obstruction. After cleaning, the main valve shall be checked for freedom of movement and proper seating, and the valve left in the closed position.
- (b) The hydrant shall stand plumb with nozzles at proper elevations above finished ground surface. Unless otherwise directed, the face of the pumper nozzle shall be parallel to the street.
- (c) The shoe or bottom of the hydrant shall be supported firmly upon a pre-cast flat concrete block. The back of hydrant and back of tee shall have poured concrete backing
- (d) Hydrant lead must be a minimum of six inches in diameter. A 6” valve shall be installed on all hydrant leads, 18” anchor couplings shall be used between tee and valve and between valve and hydrant. Hydrant shall be back-filled up to and minimum 6” above weep holes with clean #67 rock and rock covered with 8 mm plastic before back-filling to prevent dirt infiltration.
- (e) Hydrants and fittings installed inside Jonesboro City Limits will be provided by CWL.
- (f) Hydrants installed outside Jonesboro City Limits will be the responsibility of the Developer. These must meet the specifications of CWL. After a period of one year CWL will number, maintain, and repair the fire hydrants.

SECTION 8 – SEWER MAINS AND PIPING

8-01. **PVC Pipe:**

Where PVC pipe is specified, it shall comply with requirements of ASTM D-3034 SDR 35 type psm poly vinyl chloride (pvc) sewer pipe and fittings or better.

8-02. **Vitrified Clay Sewer Pipe:**

All clay sewer pipe and fittings for sanitary sewers shall be of the best quality of hard-burned vitrified glazed clay bell and spigot sewer pipe meeting the requirements of ASTM Designation C 13-57T.

8-03. **Jointing Vitrified Clay Pipe:**

(a) The vitrified glazed clay pipe shall have factory applied joints or coupling on the spigot and bell ends of the pipe meeting ASTM Designation C 425, latest revision, and compounded of a high quality polyurethane elastomer applied to the pipe and properly manufactured to a desired hardness and compressibility to form a tight compression joint. The resilient polyurethane should have the following characteristics:

- (1) A minimum tear strength of 50 psi.
- (2) Percent elongation of not less than 80% and shall return to original volume and shape upon release of elongation force.
- (3) A compression set value of less than 5%.
- (4) A minimum resistance to deflection of 165 psi at 10% deflection.
- (5) A minimum (shore "A" durometer) hardness of 70 from a temperature range of 20°F - 100°F.

The factory applied joint shall be the Dickey coupling, as manufactured by the W.S. Dickey Manufacturing Company, or an approved equal.

(b) In jointing vitrified glazed pipe, the surface shall be wiped free of dust, dirt, gravel, or other foreign matter prior to the application of the lubricant. The vitrified glazed clay pipe with the factory applied coupling shall be connected by first brushing upon the mating surfaces the prior lubricant as recommended by the pipe supplier. The spigot end shall then be centered in grade into the bell end of the last downstream clay pipe length and shoved "home" and properly seated with the application of a moderate force by a pry or lever device.

8-04. **Ductile Iron Pipe:**

Where ductile iron pipe is specified, it shall be as described in Paragraph 4-02.

8-05. **Construction In General:**

Construction of sanitary sewers shall begin at the low point of the line and continue in orderly succession throughout the work as directed by the engineer. Any deviation from this procedure shall be made only with the specific approval of the engineer. Construction shall begin only after the right of way has been cleared, the entire section staked, and the elevations carefully checked.

8-06. **Construction By General Contractors:**

Construction of sanitary sewers shall begin at the low point of the line and continue in orderly succession throughout the work as directed by the developer's engineer and approved by CWL's engineer. Any deviation from this procedure shall be made only with the specific approval of both the developer and CWL engineers.

Construction shall begin only after approved plans from the Arkansas Department of Health are submitted to CWL, and all necessary fees are paid in full. Construction by contractors shall then begin only after the right of way has been cleared, the entire section staked, and the elevations carefully checked.

CWL Specifications

Developer, along with a representative of the Contractor if different, shall meet with a representative of CWL on the first day planned for construction, to review any common issues. During construction, work shall be inspected by the Developer's consulting engineer for necessary safety practices, proper materials, and workmanship. CWL will provide inspections during construction, and other random inspections to insure that the plans approved by the Arkansas Department of Health and CWL are followed concerning workmanship and materials. No portion of the project shall be backfilled without CWL approval.

8-07. Excavation:

The bottom of the trench shall be excavated to a true line and grade according to the grades and lines furnished by the Engineer. For pipe sewers, the bottom of the trench under each bell shall be excavated sufficiently to allow the pipe to rest throughout its length. Bell hole excavation shall also be sufficient to allow proper placing of the joint compound. Should rock be encountered at excavation, contractor will backfill with suitable bedding material a minimum of 4" over said rock.

8-08. Laying Sewer Pipes:

- (a) Sewer pipe shall be laid on a firm bed and in a perfect conformity with lines and levels given.
- (b) All PVC sewer pipe shall be laid on no less than 4" of ¾ minus chat laid with even bearing on the bottom of the trench which shall be slopped with the earth and prepared to conform to the form of the pipe by back-filling with ¾ minus chat up to the "spring-line" of the pipe.
- (c) All other pipe shall be laid with even bearing on the bottom of the trench, which shall be slopped with earth and prepared to conform to the form of the pipe. Sufficient dimensions shall be cut in the bottom of the trench to achieve perfect clearance to the bell of the pipe, but not larger than is necessary to make a proper joint.
- (d) All water entering the excavations or other parts of the work shall be removed until all the work has been completed. No sanitary sewer shall be used for the disposal of trench water, unless specifically approved by the engineer, and then only if the trench water does not ultimately arrive at existing pumping or wastewater treatment facilities.
- (e) The inside shoulder of the bell and spigot ends must in all cases meet; the bell end in all cases shall be laid toward the high end of the sewer.
- (f) The grade of the pipe shall be obtained by the use of a pipe laser. The laser shall be placed in the pipe and a target utilized for grading and placement of pipe.
- (g) At the end of each day's work, and when pipe laying is discontinued for any reason, open ends of pipe shall be closed with a cast plug or cap firmly secured.
- (h) Final backfill shall be of suitable material removed from excavation except where other material is specified. Debris, frozen material, large clods or stones, organic matter or other unstable materials shall not be used for final backfill within 2 feet of the top of the pipe.
- (i) Final backfill shall be placed in such a manner as not to disturb the alignment of the pipe.

8-09. Manholes:

Poured in place or pre-cast concrete manholes will be used.

- (a) In general, pre-cast concrete manholes shall be manufactured in compliance with ASTM Designation 1964 C 478. The concrete used shall have a compressive strength of 4000 psi; maximum absorption determined by boiling test shall be 8%. Aggregate shall be crushed limestone. Commercial fiber reinforcement shall be 1½ lbs per cubic yard of concrete.
The internal diameter of the manhole section shall be 48 inches and the wall thickness of 5 inches. The cone sections shall have internal diameters of 48 inches at the base and 24 inches at the top and a vertical length of 36 inches with no steps. Other manhole sections shall be made in length of 16, 32, 48, and 64 inches.
- (b) All casting for manhole heads, covers, and other purposes must be made of heavy duty gray iron. Manhole cover should be 250 lbs and 24" diameter Western type or equivalent. Must be free from cracks, holes, swells, and cold sheets and have a workmanlike finish.
- (c) Manhole bottoms and inverts shall be made of Class "A" concrete.

CWL Specifications

- (d) Drop manholes shall be constructed at all manholes where the difference in invert elevation between incoming and outgoing sewer is 2.0 feet or more. Drop manholes shall be constructed of the same materials and dimensions as are standard manholes, the only difference being the inlet configuration as shown on the standard details sheet.
- (e) Manholes shall be vacuum tested in accordance with ASTM C 1244-93.
- (f) The specifications shall include a requirement for inspection and testing for water tightness or damage prior to placing into service, e.g. manhole bottoms and walls must be free of leakage prior to vacuum test. Also where existing manholes in service are to be broken into prior to a sewer main extension, the existing manholes must be re-vacuum tested.
- (g) The flow channel should be made to conform to the connecting sewers. The angle between connecting sewers shall be a minimum of 90°.
- (h) Straight-line manholes should drop one-tenth of a foot from inlet invert to outlet invert. Manholes that change alignment greater than 45 degrees should drop one-quarter of a foot from inlet invert to outlet invert.

8-10. Infiltration:

- (a) An air pressure test shall be performed on all contractor laid sewer pipe per ASTM C 828-80.
- (b) After job completion and ditch settlement, infiltration or pipe leakage, shall not exceed 100 gallons per day per mile of pipe per inch of pipe diameter.

8-11. Deflection:

All flexible laid sewer pipe shall be tested with a mandrel. Deflection shall not exceed 5%. The test shall be performed without mechanical pulling devices. The test shall be conducted after the final backfill has been in place for at least 30 days.

8-12. Plugging Manholes (when tying into existing manholes):

The downstream side of the first manhole within a sewer extension, must be mechanically plugged to prevent infiltration into CWL's sewer system. The plug must be supplied by the developer or contractor. This separation from CWL's sewer system must be maintained by the developer/contractor until final acceptance by CWL.

Slope

All sewers shall be designed and constructed to give velocities of not less than 2.0 feet per second based on Manning's formula using an "n" value of 0.013.

Slope	Min. Slope in Feet per 100 Feet
8 inch	0.40
10 inch	0.28
12 inch	0.22
15 inch	0.15
18 inch	0.12
21 inch	0.10
24 inch	0.08
30 inch	0.058
42 inch	0.037

SECTION 9 – LIFT STATIONS

9-01. Lift Station Structure (Same as manhole):

Poured in-place or pre-cast concrete; Lift Station will be used.

In general, pre-cast concrete Lift Station shall be manufactured in compliance with ASTM Designation 1964 C 478. The concrete used shall have a compressive strength of 4000 psi; maximum absorption determined by boiling test shall be 8%. Aggregate shall be crushed limestone. Steel reinforcement shall consist of a single line of circumferential reinforcement, placed in the center of the concrete pipe wall, with a minimum sectional area of .17 square inches per foot of pipe length. Fiber reinforcement shall be 1½ lbs. per cubic yard of concrete.

The inside diameter of the manhole section shall be 72” and the wall thickness of 5 inches. Soil tests shall be taken to design footing width.

9-02. Check Valve Installation:

Check valves and gate valves shall be installed in a 5’ diameter vault with concrete floor. Vault bottoms and walls shall be free of all leakage. Vault shall have 36” x 36” or larger aluminum, single leaf, locking access door. Each pump shall have it’s own set of check valves and gate valves with the gate valve on the down stream side of the check valve. Check valves and gate valves shall have adequate weight support at each location. All gate valves and check shall be easy operable and accessible for maintenance and replacement. Provisions shall be made to remove or drain accumulated water from the valve chamber. The valve chamber may be dewatered to the wet well through a drain line with a gas and water tight valve.

9-03. Lift Station Valves:

- (a) *Check Valves* shall be flange type, cast iron or bronze body, fully ported, resilient seated, with a outside weight and lever. Designed for 175 psi working pressure. Check valves shall conform to A.W.W.A. C 508-82.
- (b) *Gate Valves* shall be flange type, cast iron or bronze body, fully ported, open left, resilient seated, with wheel type operation. Designed for 175 psi working pressure. Gate valves shall conform to A.W.W.A. C 500-80.

9-04. Pump and Piping:

- (a) Pump and piping installation shall be completed before any sewage is admitted into basin and should be clean.
- (b) Installation of piping shall be inspected by CWL during the construction of all Ductile Iron piping. Pipe shall be class 150 Ductile Iron with cast-on type flange end x plain end.
- (c) Flange gasket shall be heavy duty red rubber 1/8” thick.
- (d) Hardware – bolts, nuts, flat washers and lock washers shall be 302 stainless steel.
- (e) Antiseize compound shall be used on threads.

9-05. Lift Station Pump Removal System Equipment

- (a) Stainless steel lift chain.
- (b) Top Rail Support.
- (c) Slide Rail Assembly 1½ “ or larger Hydromatic Stainless Steel.
- (d) 30” x 48” or larger single door aluminum access cover.

9-06. Pump Removal

- (a) Submersible pumps shall be readily removable and replaceable without dewatering the wet well or disconnecting any piping in the wet well.
- (b) Provisions shall be made to facilitate removing pump, motors and mechanical and electrical equipment.

CWL Specifications

- 9-07. **Control Panel** shall not be mounted directly on top of wet well basin. The power and control wires shall be taken into an air-tight junction box.
- 9-08. **Pump Power Cables** ends shall never come in contact with water. If the cables are extended, do not immerse the splice in water. Install the cable so that it will not over heat. Overheating is caused by coiling the cable and exposing it to direct sunlight. Use short circuit breakers to prevent danger of electrical shock.
- 9-09. **Seal Failure** – All motors shall have seal failure probe installed near the bottom so that any leakage will be detected. A red warning light at the control panel comes on if water enters seal chamber. This is an indicator only and does not stop motor, but warns that seal should be replaced.
- 9-10. **Heat Sensor** – All motors shall have a heat sensing thermostat installed in top of winding in the motor. Any motor winding temperature above 248°F will open thermostat and stop motor. Thermostat will automatically reset as soon as it has cooled.
- 9-11. **Level Controls** shall be held by support bracket and cords are adjusted for proper depth. A sealed mercury switch at the bottom with adjustable lead weights.
- Lower turn-off control shall be set so that pump stops when water level is about to top of motor.
 - Upper turn-on control is set to start pump when level is at height specified above pump.
 - Over-ride control is set a height specified above upper turn-on control.
 - Alarm control is set at 6" to 12" above override control.
 - No control should be set above lowest inlet invert.
- 9-12. **PUMP, MOTOR, & CONTROL ITEMS:**
- Weather-proof control panel with locking hasp.
 - Duplex junction box.
 - 5 level control support bracket with lead weights.
 - Level control cord.
 - Remote alarm panel, NEMA 3R enclosure light.
 - Alarm light red globe solid state.
 - Alarm buzzer.
 - Convenience outlet receptacle.
 - Elapsed time meter.
 - Auxiliary contacts.
 - Motor heat sensor.
 - Lightning arrestor.
 - Moisture sensor.
 - Sealed mercury switch.
- 9-13. **Backflow Preventer** – There shall be no physical connection between the potable water system and the wet well. If potable water is injected into wet well it shall have an approved air gap and must be at least twice the diameter of the water supply outlet, but never less than 1".
- 9-14. **Accessibility** to lift station and equipment shall be provided for maintenance vehicles during all weather conditions and must be approved by CWL.

SECTION 10 – FORCE MAIN LINES

- 10-01. **Pipe and Design Pressure:**
Pipe shall be PVC with a Pressure Rating (PR) of 200 (SDR 21) or better conforming to ASTM D2241 and ASTM 3139.
Fittings shall be cast iron and equal to water main strength materials suitable for design conditions. Thrust blocking and fittings should be designed to withstand water hammer pressures associated with the cycling of the lift station pumps.
- 10-02. **Installation of Force Mains:**
Installation of force mains shall be in accordance with requirement of Sections 3 through 6 of the CWL Specifications for water and sewer construction.
- 10-03. **Velocity and Diameter of Force Main:**
The design for pumping rates should be at a cleansing velocity of at least two feet per second. The minimum force main diameter for raw wastewater shall be four inches, unless approved by CWL and Arkansas Department of Health.
- 10-04. **Air and Vacuum Relief Valves:**
Air and Vacuum Relief Valves shall be placed in 46” diameter manhole and be placed at the high point of the force main to relieve any air when the pumps come on and relieve any vacuum when the pumps go off.
- 10-05. **Force Main Termination:**
Force Main Termination shall enter the gravity manhole near the bottom (a maximum of 1 foot from the invert). Also, the manhole must be a minimum of 8 feet in depth.

SECTION 11 – CONTRACTOR/DEVELOPER AGREEMENTS

11-01. Water Extensions:

1. Plans for the proposed work must be prepared by a professional engineer registered in the State of Arkansas and submitted to CWL. Developer will use CWL's specifications on file at the Arkansas Department of Health, unless mutually agreed by the parties.

2. Upon approval by CWL, Developer's consulting engineer will submit plans, if necessary, to the Arkansas Department of Health for State approval. An inspection fee will be paid to CWL at a rate of \$0.25/ft of line. Subdivision plans must have final approval by MAPC and be filed at the Circuit Court Clerk's office prior to final approval of the system. Any construction occurring prior to such final approval by MAPC shall be at the risk of the Developer.

3. Unless the installation is to be performed on existing public right-of-way, Developer shall furnish easements in favor of CWL and to its specifications across private property. Unless the easement is provided on property included in the original subdivision plat, Developer shall furnish a certificate of title showing ownership of the property covered by the easement.

4. Upon approval by Arkansas Department of Health and acquisition of all easements, construction may begin. Construction must be performed by a qualified contractor knowledgeable in all federal, state and local rules and regulations governing this type of work. Developer must show proof of adequate insurance coverage. (Arkansas Worker's Compensation, \$1,000,000.00 minimum general liability, and \$1,000,000.00 minimum auto liability.) Such insurance may be furnished to CWL by either the Developer or by the Contractor. Contractor must have a State Contractors License, which shall cover Municipal and Utility Construction or a classification specialty covering underground piping, cable, trenching, and boring. .

5. Developer, along with a representative of the Contractor if different, shall meet with a representative of CWL on the first day planned for construction, to review any common issues. During construction, work shall be inspected by the Developer's consulting engineer for necessary safety practices, proper materials, and workmanship. CWL will provide inspections during construction, and other random inspections to insure that the plans approved by the Arkansas Department of Health and CWL are followed concerning workmanship and materials. No portion of the project shall be backfilled without CWL approval.

6. If unsafe practices are discovered by CWL during our inspections of workmanship and materials, CWL will notify the OSHA. This in no way obligates CWL for the responsibility of the Contractor's safety practices.

7. Contractor must pressure test lines to 1.5 times the anticipated working pressure of the water line as calculated by CWL. Contractor shall perform Sterilization per CWL Specifications section 4-09. Contractor shall follow flushing guidelines as per CWL Specifications Section 4-10. Costs for above normal flushing will be the responsibility of the Developer/Contractor.

8. Upon completion of project, the Developer's consulting engineer will certify by letter that all work was accomplished in accordance with all approved plans and specifications and provide CWL with a set of record drawings, which shall include plans but not specifications. The consulting engineer will also certify that all easements have been obtained, that all water is laid on the easements or right-of-way.

9. Developer shall arrange a post construction meeting including the Engineer, and a representative of the Contractor, to meet with a representative of CWL prior to final approval by CWL.

10. The Developer will furnish CWL with a written warranty for one (1) year from acceptance date. This warranty will cover any defects in workmanship and/or materials, maintenance of lines, fill and/or other surface improvements, and grade adjustments of improvements located on or near the construction area. Emergency repairs will be performed by CWL and costs billed to the Developer.

11. The Developer will certify by letter that no liens exist on the work performed. A list of all contractors, subcontractors and material suppliers that worked or supplied materials on the job and a lien release from each will be submitted to CWL with this letter.

12. Newly constructed lines will not become a part of CWL's existing system until final approval has been given by CWL Engineering Department by letter. On the date of the acceptance letter, CWL will assume ownership and warranty will begin.

13. Contractor must bury locate wire in trench per CWL requirements.

CWL Specifications

14. Installation of domestic water meter taps are required to be made during the installation of the new water mains.

15. Electric Underground Installation (Where applicable):

(a) In order to simplify the contribution that Developers make for underground electric when they also install water lines, CWL will require that Developers install the underground electric conduit. This will be in lieu of paying the standard underground electrical charges.

(b) A mouse and string must be blown in after all applicable work is completed. Replacement or repair of conduit that is unusable for any reason will be the responsibility of the Developer. The Developer will provide all material, labor and equipment. CWL will provide the appropriate engineering drawings.

16. Contractor shall indemnify and hold harmless CWL, its' officers, agents and employees from and against any and all claims, losses, damages, causes of action, suits, and liability of every kind, including all expenses of litigation, court costs, and attorney's fees, including but not limited to personal injury to or death of any person or for damage to any personal or real property arising out of or in connection with the work performed or products or equipment provided by the Contractor.

17. On all water projects that have not been accepted by CWL within 360 days after hydrostatic tests and bacterial tests, all tests will be required to be repeated and re-certified.

18. It is the intent of this agreement that the basic responsibility for performance with the requirements hereof shall be the responsibility of the Developer, who shall be fully responsible for all activities of the Contractor and shall directly respond to CWL regarding all such Contractor activities.

11-02. Sewer Extensions

1. Plans for the proposed work must be prepared by a registered professional engineer registered in the State of Arkansas, and submitted to CWL. Developer will use CWL's specifications on file at the Arkansas Department of Health, unless mutually agreed by the parties.

2. Upon approval by CWL, Developer's consulting engineer will submit plans, if necessary, to the Arkansas Department of Health for State approval. An inspection fee will be paid to CWL at a rate of \$0.50/ft for gravity lines and \$0.25/ft for force main lines. Subdivision plans must have final approval by MAPC and be filed at the Circuit Court Clerk's office prior to final approval of the system. Any construction occurring prior to such final approval by MAPC shall be at the risk of the Developer.

3. Unless the installation is to be performed on existing public right-of-way, Developer shall furnish easements in favor of CWL and to its' specifications across private property. Unless the easement is provided on property included in the original subdivision plat, Developer shall furnish a certificate of title showing ownership of the property covered by the easement.

4. Upon approval by Arkansas Department of Health, construction may begin. Construction must be performed by a qualified contractor knowledgeable in all federal, state and local rules and regulations governing this type of work. Developer must show proof of adequate insurance coverage. (Arkansas Worker's Compensation, \$1,000,000.00 minimum general liability, and \$1,000,000.00 minimum auto liability.) Such insurance may be furnished to CWL by either the Developer or by the Contractor. Contractor must have a State Contractors License, which shall cover Municipal and Utility Construction or a classification specialty covering underground piping, cable, trenching, and boring.

5. Developer, along with a representative of the Contractor if different, shall meet with a representative of CWL on the first day planned for construction, to review any common issues. During construction, work shall be inspected by the Developer's consulting engineer for necessary safety practices, proper materials, and workmanship. CWL will provide inspections during construction, and other random inspections to insure that the plans approved by the Arkansas Department of Health and CWL are followed concerning workmanship and materials. No portion of the project shall be backfilled without CWL approval.

CWL Specifications

6. If unsafe practices are discovered by CWL during our inspections of workmanship and materials, CWL will notify OSHA. This in no way obligates CWL for the responsibility of the Contractor's safety practices.

7. All gravity lines must pass ASTM C 828-80 low pressure air test for sanitary sewers. All force main lines must pass a pressure test equivalent to 1 ½ times its expected working pressure. All manholes shall pass ASTM C 1244-93 vacuum test for concrete sewer manholes.

8. Upon completion of project, the Developer's consulting engineer will certify by letter that all work was accomplished in accordance with all approved plans and specifications and provide CWL with a set of record drawings, which shall include plans but not specifications. The consulting engineer will also certify that all easements have been obtained, that all sewer is laid on the easements or right-of-way.

9. Developer shall arrange a post construction meeting including the Engineer, and a representative of the Contractor, to meet with a representative of CWL prior to final approval by CWL.

10. The Developer will furnish CWL with a written warranty for one (1) year from acceptance date. This warranty will cover any defects in workmanship and/or materials, maintenance of lines, fill and/or other surface improvements, and grade adjustments of improvements located on or near the construction area. Emergency repairs will be performed by CWL and costs billed to the Developer.

11. The Developer will certify by letter that no liens exist on the work performed. A list of all contractors, subcontractors and material suppliers that worked or supplied materials on the job and a lien release from each will be submitted to CWL with this letter.

12. Newly constructed lines will not become a part of CWL's existing system until final approval has been given by CWL Engineering Department by letter. On the date of the acceptance letter, CWL will assume ownership and warranty will begin.

13. Contractor shall indemnify and hold harmless CWL, its' officers, agents and employees from and against any and all claims, losses, damages, causes of action, suits, and liability of every kind, including all expenses of litigation, court costs, and attorney's fees, including but not limited to personal injury to or death of any person or for damage to any personal or real property arising out of or in connection with the work performed or products or equipment provided by the Contractor.

14. On all sewer projects that have not been accepted by CWL within 360 days after mandrel tests and low pressure tests, all tests will be required to be repeated and re-certified.

15. It is the intent of this agreement that the basic responsibility for performance with the requirements hereof shall be the responsibility of the Developer, who shall be fully responsible for all activities of the Contractor and shall directly respond to CWL regarding all such Contractor activities.

11-03. **Construction Inspection Policy:**

On all sewer projects that have not been accepted by CWL within 360 days after mandrel tests and low pressure air tests, all tests will be required to be repeated and re-certified.

On all water projects that have not been accepted by CWL within 360 days after hydrostatic tests and bacterial tests, all tests will be required to be repeated and re-certified.

11-04. **Water Meter Tap Policy:**

Installation of domestic water meter taps are required to be made during the installation of the new water mains.

11-05. **Electric Underground:**

In order to simplify the contribution that developers make for underground electric when they also install the water lines, City Water and Light will require that developers install the underground electric conduit. This will be in lieu of paying the standard \$2.50/ft charge.

CWL Specifications

The 2" conduit must be gray schedule 40 and the 4" conduit must be gray type II pipe. The elbows must have a 36" radius. A mouse and string must be blown in after all applicable work is completed. Replacement or repair of conduit that is unusable for any reason will be the responsibility of the developer. The developer will provide all material, labor, and equipment. City Water and Light will provide the appropriate engineering drawings.

July 2000
Reprinted 2012

**CITY WATER & LIGHT PLANT
JONESBORO, AR**

SAFETY RULES

FOR ALL CONTRACTORS

AND

CONTRACTORS' EMPLOYEES

ON ALL

CITY WATER & LIGHT

PROJECTS

PREFACE

City Water & Light Plant of the City Jonesboro, (hereinafter referred to as "CWL") is committed to conducting construction operations in the safest manner as required by applicable laws, rules and regulations.

We require the full cooperation of all Contractors to effectively carry out this commitment.

This guide has been provided to familiarize all Contractors with CWL's safety rules, procedures and the guidelines for controlling jobsite accidents and injuries.

The safety rules listed on the following pages are **minimum** safety rule requirements of CWL. You will be expected to comply with these rules.

Any safety procedures initiated by CWL shall not be construed as supervision of the contractor's work force, nor make CWL responsible for providing a safe place for the performance of work by the Contractor or the Contractor's employees or those of the suppliers, or his subcontractors; nor for access, visits, use, work, travel or occupancy by any person, as these responsibilities shall be covered by the Contractor and the Contractor's insurance, and cannot be the responsibility of CWL or their representative.

Although CWL or their representatives may recognize safety hazards and in such case will require that changes be made to reduce or eliminate the hazards, CWL or their representative by such action does not take the responsibility as safety engineer or safety inspector for the contractor. Neither does such action indicate that CWL or their representative is a trained safety engineer or safety inspector. It means only that a specific safety hazard has been recognized in the ordinary course of inspection of the technical aspects of the work being done, and such hazard has been called to the attention of the Contractor.

I. SAFETY RULES

EACH CONTRACTOR IS EXPECTED TO BE AWARE OF AND COMPLY WITH FEDERAL, STATE AND LOCAL SAFETY REGULATIONS.

Contractors will agree to comply with all Federal, State, and local statutes, ordinances, and requirements, and have agreed to hold CWL and its employees harmless for all claims, damages (including legal fees), and/or penalties incurred as a result of Contractor failures to comply with such regulations.

II. VIOLATIONS

If unsafe conditions or practices are observed by CWL's Authorized Representative, the Contractor will be requested to correct them. If no action is taken, a CWL Authorized Representative will take appropriate action as needed to correct such unsafe conditions or practices.

Failure or refusal to comply or enforce any part of these safety rules or any applicable law may result in:

- a.) Removal of the employee involved in the violation from the job site.
- b.) Removal of all employees from the job site.
- c.) Denial of future bid opportunities for CWL.
- d.) Cancellation of contract with 5 days written notice.

III. CONTRACTOR LICENSE & INSURANCE

Contractors must have a valid State of Arkansas Contractors License in accordance with the State of Arkansas contractors Licensing Board. (501-372-4661 phone 501-372-2247 fax)

Contractors must provide proof of:

- a.) General Liability Insurance-Limits and Endorsements
Depend on the project but a minimum of \$1,000,000 should be considered.
- b.) Auto Insurance-Usually the same as GL but can depend on the project.
- c.) Worker's Compensation Insurance-As required by Arkansas Law
- d.) OCP-(Owners and Contractors Protective Liability)
-This transfers the liability premium for CWL protection to the contractor.
- e.) Builders Risk-This physical damage coverage is sometimes included in specs for the contractor to provide it, and sometimes the owner provides the coverage.
- f.) Hold Harmless Clause-This is a standard provision in contracts with general contractors that transfers risk to the contractor. This does not change the requirements for insurance.

Note: Consult CWL Insurance Guidelines. CWL's Financial Services Director will determine adequate coverage.

IV. TRAFFIC CONTROL

When working in road right-of-way, the contractor must comply with Part VI Standards and Guides for Traffic Controls for Street and Highway Construction, Maintenance, Utility, and Incident Management Operations. (Part VI of the Manual on Uniform Traffic Control Devices) –U.S. Dept. of Transportation-Federal Highway Administration.

V. REPORTING TO ARKANSAS DEPARTMENT OF LABOR-SAFETY DIVISION

CWL complies with Arkansas Public Law Act 291 1993 Section 2. This Act requires CWL to report to the Arkansas Department of Labor any trench or excavation job that equals or exceeds five (5) feet in depth. CWL's contract must specifically require the Contractor to include a separate pay item for trench or excavation safety systems to be included in the base bid.

VI. PERSONAL SAFETY OF EMPLOYEES

OSHA 1926 Subpart E and 1910 Subpart I

Any persons on a CWL job site will wear safety attire appropriate to the job being performed.

VII. CWL ALCOHOL AND DRUG WRITTEN PROGRAM

Illegal and unauthorized substances and drugs, lookalike drugs, synthetic drugs, alcoholic beverages, and drug paraphernalia are strictly prohibited on any CWL Property or Construction site. Any person found to be using or in possession or concealment of any of the above mentioned unauthorized items will not be allowed on CWL's Property or Construction site. Any person under the influence of drugs or alcohol will be removed from the construction site. All persons, their vehicles, and personal property are subject to search and inspection before entering, while on or departing CWL's property or the job site. All persons are subject to CWL's Alcohol and Drug Testing Program unless Contractor has provided proof of such program within their company. A copy of the Contractor's Alcohol and Drug Written Program will be submitted to CWL's Compliance Specialist for review before the Contractor is allowed to bid a CWL project. If the Contractor does not have such program in place, then CWL's Alcohol and Drug Written Program will be followed and the expense of such testing will be reimbursed to CWL by the Contractor.

VIII. CONTRABAND AND FIREARMS – CWL POLICY

Contraband, stolen property, firearms, weapons, explosives, and any other hazardous substance are strictly prohibited on a CWL Construction site or property. Any person found to be using or in possession, or concealment of any of the above unauthorized items will be removed from the job site and will not be allowed to return to CWL's Construction site or property.

IX. SEXUAL HARASSMENT POLICY – CWL

It is the policy of CWL to take action to provide a workplace and work site free of any verbal or physical behavior of a sexual nature that creates an offensive working atmosphere either to the employee or general public. When a working condition or action creates a working atmosphere offensive to an employee or the general public, CWL will take immediate action to investigate the problem.

X. WORKPLACE VIOLENCE POLICY – CWL

Any person who makes substantial threats, exhibits threatening behavior or engages in violent acts while employed under contract with CWL shall be removed from the premises or work site as quickly as safety permits and shall remain removed pending the outcome of any investigation.

XI. ARKANSAS ONE CALL

The Contractor will be responsible for making sure the location of all underground utilities have been successfully marked before digging, trenching, excavation, etc. begins while under contract with CWL. Call ARKANSAS ONE CALL at 1-800-482-8998 48 hours prior to beginning excavation.

XII. HAZARD COMMUNICATIONS – OSHA 29 CFR 1910.1200

In accordance with CWL's Hazard Communication Written Program, all hazardous materials containers must be properly labeled. A list of the hazardous materials used on the job site by CWL and Contractors will be maintained by CWL's Authorized Representative assigned the project. This list will be given to CWL's Authorized Representative assigned when the Contractor enters into a contract with CWL. The Contractor shall supply a Material Safety Data Sheet for all items listed prior to beginning work. A copy of these MSDS's will be forwarded to the office of CWL's Compliance Specialist for review. If additional hazardous materials are introduced to the job site, notification and a copy of the MSDS will be supplied to CWL's Authorized Representative assigned before the hazardous material is allowed on the job site. A copy of CWL's Hazardous Communication Written Program may be obtained by requesting such from CWL's Engineering Department.

XIII. TRENCHING AND EXCAVATIONS

All trench and excavations will comply OSHA 29 CFR 1926 Subpart P.

XIV. CONFINED SPACE

All persons are expected to comply with OSHA 29 CFR 1910.146 and CWL's Written Confined Space Program. A copy may be obtained by requesting such from CWL's Engineering Department.

XV. MOTORIZED EQUIPMENT

All Contractors are expected to comply with OSHA 29 CFR 1916 Subpart O. When equipment is shut down for the night, weekends, etc., buckets shall be lowered to the ground and equipment immobilized so that unauthorized persons cannot operate the equipment. All engines shall be shut off when refueling. Only authorized and properly instructed persons shall operate machinery, equipment, tools or vehicles. A flagman shall direct the backing of a vehicle in congested areas.

XVI. MATERIAL HOISTS

Riding on material hoist equipment at any time is prohibited.

XVII. CRANES

Accessible areas within the swing radius of all cranes must be barricaded to prevent injuries by the counter weight. **All persons are prohibited from riding the load or the headache ball.** Safety latches are required on all crane hooks. No crane or other equipment shall be operated within 10 feet of 50kV (phase-to-ground voltages). Over 50kV the distance shall be 10 feet plus 0.4 inches for each 1 kV over 50kV energized electrical transmission or distribution lines.

XVIII. VEHICLES OR EQUIPMENT

All persons are instructed not to jump off vehicles or equipment, materials, edges of trenches, mounds of dirt, etc. To do so could result in an on-the-job injury. All persons are to stay clear of the sides of loaded flatbeds especially when being unloaded from the sides, rear of loaded dump trucks, front of front end loaders, etc. The operator of the vehicles or equipment has a responsibility to others on the ground around the work site as well as those on the ground around the work site has a responsibility to watch for vehicles or equipment in movement whether loading, unloading, etc.

XIX. POWERED INDUSTRIAL TRUCKS (FORKLIFTS) – OSHA 29 CFR 1910.178(1)

All Contractors will meet the requirements of 29 CFR 1910 regulating the use and operation of powered industrial trucks (forklifts).

XX. ELECTRICAL EQUIPMENT – OSHA 29 CFR 1910 SUBPART S

Contractors are responsible for maintenance of their extension cords. Defective extension cords should be removed from service, OSHA does require daily inspection of extension cords for broken grounds, breaks in the insulation, etc., and does require testing of the extension cords and tools on a quarterly basis to assure that grounds are operative. Contractors are expected to comply with the assured grounding program required by OSHA or use a GFCI system.

XXI. LOCKOUT/TAGOUT – OSHA 29 CFR 1910.147 SUBPART J

All contractors are required to comply with OSHA's control of hazardous energy (lockout/tagout) standard. This standard covers the servicing and maintenance of machines and equipment in which the unexpected energization or start up of the machines or equipment, or release of stored energy could cause injury to employees.

XXII. COMMERCIAL DRIVER'S LICENSE (CDL)

All operators of vehicles requiring the driver to possess a CDL will be in compliance with the Federal Motor Carriers Safety Regulations 49 CFR 391 and the State of Arkansas. Subpart E Part 391.43(c) requires a Medical Examiner's certificate. A driver must be included in an Alcohol and Drug Testing Program by their employer or be a member of a controlled substance test consortium (391.105).

XXIII. UTILITIES

Equipment operators and truck drivers must be cautioned not to operate closer than recommended distances from overhead electrical wires. If work is required within close proximity to these wires, consult with CWL's Engineering Department about the possibility of relocating, de-energizing or insulating wires to protect all persons.

XXIV. FIRE PROTECTION – OSHA 29 CFR 1926 SUBPART F

“No Smoking” signs should be posted and obeyed in areas where flammables are stored or used. Smoking is not allowed in any of CWL’s facilities. Good housekeeping practices are important. Combustible materials should be placed in trash barrels, and not permitted to accumulate in the work area or the job site. When portable heaters are used, make sure that they are placed well away from combustible materials. When welding, cutting or using flammable materials it is the responsibility of the Contractor to have adequate fire extinguishers at the work location. A fire watch shall be maintained when there is a fire exposure because of welding or cutting operations that do not confine sparks to the immediate area. Fire extinguishers are not to be tampered with or removed from assigned locations. Expired or used extinguishers are to promptly replaced or recharged.

XXV. HOUSEKEEPING

Contractors are responsible for housekeeping conditions on their respective job sites. Refuse and scraps should not be allowed to accumulate, particularly when they interfere with workflow or create additional fire hazards. Continuous cleanup will help to reduce the exposure to accidents and fires, and make it easier for everyone to get their work accomplished. **Debris-free work sites will create a positive image to the citizens we serve.** Caution will be taken to prevent debris from traveling to other properties. If debris should travel from the work site, the contractor will promptly work to correct the situation. Refer to 29 CFR 1926 Subpart F for complete standards on Fire Protection and Prevention.

XXVI. FALL PROTECTION

Contractors will comply with OSHA 29 CFR 1926 Subpart M-Duty to have fall protection. When a fall of 6’ or more could occur, whether it be from a building roof, scaffolding, water storage tank, trench or etc., the contractor will take the necessary precautions as outlined in Subpart M. Subpart M refers to Subpart L, N, R, S, V, and X as well depending on the workplace, conditions, operations, and circumstances for which fall protection shall be provided.

XXVII. MEDICAL FACILITIES

First aid supplies will be made available by Contractors to all persons on the job site. Emergency telephone numbers and procedures will be conveyed to all persons. The emergency numbers will include 911 for Craighead County, Arkansas. A person trained in your company's Emergency Action Plan will be available on the job site. The person must be trained in CPR & First Aid. Adequately trained persons on the job depend on the number of persons on the job site and the type of work being performed. All persons on the job site will be informed of emergency procedures.

CWL will be informed immediately of any personal injuries on the job site and damage to property. Notify Authorized Representative (930-3320/935-5581) assigned to the project **and** CWL's Compliance Specialist (930-3316/219-5249/935-5581)

XXVIII. INSPECTIONS

Contractors are encouraged to check the areas where all persons are working and report any unsatisfactory conditions to CWL's Authorized Representative assigned to the project or to CWL's Compliance Specialist. Periodic safety inspections may be performed on all CWL job sites. These will be conducted either by CWL's Authorized Representative or CWL's Compliance Specialist. The Arkansas Department of Labor, CWL's Insurance Carriers' Inspectors, and any other regulatory authority having jurisdiction of CWL's job sites will be allowed to perform inspections. If a regulatory authority having jurisdiction over CWL's job sites visits for an inspection, the Contractor is to notify CWL's Authorized Representative assigned to the project or CWL's Compliance Specialist as soon as possible.

If unsafe conditions are identified, refer to violations under Section II.

XXIX .SECURITY OF JOB SITE

Each job site will be secured by the Contractor in such a manner as to prevent accidental entry to a hazardous area. This is for the protection of all persons on the job, others on the job site due to deliveries, and the general public. Barricades with flashing lights, signs, and whatever means necessary will be used to secure the job site.

NOTICE

CWL may request proof of compliance required by any safety rule or regulation.

STATEMENTS AND PAYROLLS

(Applicable to all Federal-aid construction contracts exceeding \$2,000 and to all related subcontracts, except for projects located on roadways classified as local roads or rural collectors, which are exempt.)

1. Compliance with Copeland Regulations (29 CFR 3):

The contractor shall comply with the Copeland Regulations of the Secretary of Labor which are herein incorporated by reference.

2. Payrolls and Payroll Records:

- a. Payrolls and basic records relating thereto shall be maintained by the contractor and each subcontractor during the course of the work and preserved for a period of 3 years from the date of completion of the contract for all laborers, mechanics, apprentices, trainees, watchmen, helpers, and guards working at the site of the work.
- b. The payroll records shall contain the name, social security number, and address of each such employee; his or her correct classification; hourly rates of wages paid (including rates of contributions or costs anticipated for bona fide fringe benefits or cash equivalent thereof of the types described in Section 1(b)(2)(B) of the Davis Bacon Act); daily and weekly number of hours worked; deductions made; and actual wages paid. In addition, for Appalachian contracts, the payroll records shall contain a notation indicating whether the employee does, or does not, normally reside in the labor area as defined in Attachment A, paragraph 1. Whenever the Secretary of Labor, pursuant to Section IV, paragraph 3b, has found that the wages of any laborer or mechanic include the amount of any costs reasonably anticipated in providing benefits under a plan or program described in Section 1(b)(2)(B) of the Davis Bacon Act, the contractor and each subcontractor shall maintain records which show that the commitment to provide such benefits is enforceable, that the plan or program is financially responsible, that the plan or program has been communicated in writing to the laborers or mechanics affected, and show the cost anticipated or the actual cost incurred in providing benefits. Contractors or subcontractors employing apprentices or trainees under approved programs shall maintain written evidence of the registration of apprentices and trainees, and ratios and wage rates prescribed in the applicable programs.
- c. Each contractor and subcontractor shall furnish, each week in which any contract work is performed, to the City of Jonesboro a payroll of wages

paid each of its employees (including apprentices, trainees, and helpers, described in Section IV, paragraphs 4 and 5, and watchmen and guards engaged on work during the preceding weekly payroll period). The payroll submitted shall set out accurately and completely all of the information required to be maintained under paragraph 2b of this Section V. This information may be submitted in any form desired. Optional Form WH-347 is available for this purpose and may be purchased from the Superintendent of Documents (Federal stock number 029-005-0014-1), U.S. Government Printing Office, Washington, D.C. 20402. The prime contractor is responsible for the submission of copies of payrolls by all subcontractors.

- d. Each payroll submitted shall be accompanied by a "Statement of Compliance," signed by the contractor or subcontractor or his/her agent who pays or supervises the payment of the persons employed under the contract and shall certify the following:
 1. that the payroll for the payroll period contains the information required to be maintained under paragraph 2b of this Section V and that such information is correct and complete;
 2. that such laborer or mechanic (including each helper, apprentice, and trainee) employed on the contract during the payroll period has been paid the full weekly wages earned, without rebate, either directly or indirectly, and that no deductions have been made either directly or indirectly from the full wages earned, other than permissible deductions as set forth in the Regulations, 29 CFR 3;
 3. that each laborer or mechanic has been paid not less than the applicable wage rate and fringe benefits or cash equivalent for the classification of work performed, as specified in the applicable wage determination incorporated into the contract.
- e. The weekly submission of a properly executed certification set forth on the reverse side of Optional Form WH-347 shall satisfy the requirement for submission of the "Statement of Compliance" required by paragraph 2d of this Section V.
- f. The falsification of any of the above certifications may subject the contractor to civil or criminal prosecution under 18 U.S.C. 1001 and 31 U.S.C. 231.

- g. The contractor or subcontractor shall make the records required under paragraph 2b of this Section V available for inspection, copying, or transcription by the authorized representatives of the City of Jonesboro or the DOL, and shall permit such representatives to interview employees during working hours on the job. If the contractor or subcontractor fails to submit the required records or to make them available, the City of Jonesboro, the DOL, or all may, after written notice to the contractor, sponsor, applicant, or owner, take such actions as may be necessary to cause the suspension of any further payment, advance, or guarantee of funds. Furthermore, failure to submit the required records upon request or to make such records available may be grounds for debarment action pursuant to 29 CFR 5.12.